



EFIS-D100

Installation Guide

This guide intended for use with Experimental/LSA/Ultralight/Microlight installations.

P/N 100478-000, Revision J

For use with firmware version 5.6

March 2022

Copyright © 2003-2022 by Dynon Avionics, Inc.

Contact Information

Dynon Avionics, Inc.
19825 141st Place NE
Woodinville, WA 98072

Technical Support

Phone: +1 (425) 224-6736, 8:00 AM – 5:00 PM (Pacific Time) Monday – Friday
Email: support@dynon.com

Sales

Phone: +1 (425) 650-1269, 8:00 AM – 5:00 PM (Pacific Time) Monday – Friday
Email: sales@dynon.com

Find Us on the Web

dynon.com – Dynon homepage
dynon.com/docs – Product documentation
dynon.com/download – Software updates for products
dynon.com/support – Support resources
dynon.com/register – Register your Dynon Avionics product
shop.dynon.com – Dynon's *secure* online store

Stay in Touch

dynon.com/newsletter – Sign up to receive Dynon's newsletter
forum.flydynon.com – Dynon-hosted forum for customers and pilots
preflight.dynon.com – Dynon's blog
facebook.com/dynonavionics
instagram.com/dynonavionics
twitter.com/dynon

Videos and Training

youtube.com/DynonAvionics – Training, events, and other videos on YouTube

Copyright

© 2003-2022 Dynon Avionics, Inc. All rights reserved. No part of this manual may be reproduced, copied, transmitted, disseminated or stored in any storage medium, for any purpose without the express written permission of Dynon Avionics. Dynon Avionics hereby grants permission to download a single copy of this manual and of any revision to this manual onto a hard drive or other electronic storage medium to be viewed for personal use, provided that such electronic or printed copy of this manual or revision must contain the complete text of this copyright notice and provided further that any unauthorized commercial distribution of this manual or any revision hereto is strictly prohibited.

Information in this document is subject to change without notice. Dynon Avionics reserves the right to change or improve its products and to make changes in the content without obligation to notify any person or organization of such changes. Visit the Dynon Avionics website (www.dynonavionics.com) for current updates and supplemental information concerning the use and operation of this and other Dynon Avionics products.

Limited Warranty

Dynon Avionics warrants this product to be free from defects in materials and workmanship for three years from date of shipment. Dynon Avionics will, at its sole option, repair or replace any components that fail in normal use. Such repairs or replacement will be made at no charge to the customer for parts or labor. The customer is, however, responsible for any transportation cost. This warranty does not cover failures due to abuse, misuse, accident, improper installation or unauthorized alteration or repairs.

THE WARRANTIES AND REMEDIES CONTAINED HEREIN ARE EXCLUSIVE, AND IN LIEU OF ALL OTHER WARRANTIES EXPRESSED OR IMPLIED, INCLUDING ANY LIABILITY ARISING UNDER WARRANTY OF MERCHANTABILITY OR FITNESS FOR A PARTICULAR PURPOSE, STATUTORY OR OTHERWISE. THIS WARRANTY GIVES YOU SPECIFIC LEGAL RIGHTS, WHICH MAY VARY FROM STATE TO STATE.

IN NO EVENT SHALL DYNON AVIONICS BE LIABLE FOR ANY INCIDENTAL, SPECIAL, INDIRECT OR CONSEQUENTIAL DAMAGES, WHETHER RESULTING FROM THE USE, MISUSE OR INABILITY TO USE THIS PRODUCT OR FROM DEFECTS IN THE PRODUCT. SOME STATES DO NOT ALLOW THE EXCLUSION OF INCIDENTAL OR CONSEQUENTIAL DAMAGES, SO THE ABOVE LIMITATIONS MAY NOT APPLY TO YOU.

Dynon Avionics retains the exclusive right to repair or replace the instrument or firmware or offer a full refund of the purchase price at its sole discretion. SUCH REMEDY SHALL BE YOUR SOLE AND EXCLUSIVE REMEDY FOR ANY BREACH OF WARRANTY.

These instruments are not intended for use in type certificated aircraft at this time. Dynon Avionics makes no claim as to the suitability of its products in connection with FAR 91.205.

Dynon Avionics' products incorporate a variety of precise, calibrated electronics. Except for replacing the optional internal backup battery in EFIS-based products per the installation guide, our products do not contain any field/user-serviceable parts. Units that have been found to have been taken apart may not be eligible for repair under warranty. Additionally, once a Dynon Avionics unit is opened up, it will require calibration and verification at our Woodinville, WA offices before it can be considered airworthy.

Table of Contents

1. Introduction	1-1
OEM Installations.....	1-1
Warning	1-1
About this Guide	1-2
Menu Descriptions	1-2
2. Wiring Overview	2-1
Recommended Wiring Practices	2-1
Power Requirements.....	2-1
25-Pin Female EFIS Harness	2-2
3. Instrument Installation	3-1
Selecting a Remote Compass Module Location	3-1
EDC-D10A Communication Cable.....	3-2
Power Inputs	3-3
Serial Communication Cable	3-4
SL30 and/or GPS connection.....	3-5
Altitude Encoder Wiring.....	3-8
Audio Alert Output.....	3-10
Dynon Smart Avionics Bus (DSAB) Wiring.....	3-11
Panel Location and Mounting	3-12
Connecting Static & Pitot Lines.....	3-13
4. EFIS Calibration and Configuration	4-1
Ensuring Proper Installation	4-1
Setting Zero Pitch (In flight).....	4-1
Compass Heading Calibration	4-1
Configure Airspeed Color Thresholds.....	4-4
5. DSAB Configuration	5-1
Network Concepts	5-1
Example Networks	5-2
Initial Setup	5-4
Brightness Configuration.....	5-5
Network Status	5-6
6. Autopilot Installation and Configuration	6-1
Additional Information and Updates	6-1
DSAB Firmware Compatibility	6-2
Compass Calibration Critical For Certain AP Modes	6-2
Autopilot System Electrical Installation.....	6-3
Servo Mechanical Installation.....	6-6
AP74 Mechanical Installation.....	6-11
Firmware Upgrades Required For AP Functionality	6-13
AP Servo Configuration	6-14
AP74 Configuration.....	6-30
7. Appendix	7-1
Appendix A: Ongoing Maintenance and Troubleshooting.....	7-1
Appendix B: Dynon OAT Probe Installation and Usage	7-7
Appendix C: HS34 Installation and Configuration	7-10
Appendix D: Dynon AOA/Pitot Installation and Calibration.....	7-24
Appendix E: Encoder Serial-to-Gray Code Converter Installation.....	7-32



Appendix F: Replacing the EFIS-D100 battery pack.....	7-35
Appendix G: Weights	7-35
Appendix H: EFIS-D100 Specifications	7-36

1. INTRODUCTION

This manual provides information about the physical, electrical, and plumbing installation of the EFIS-D100, EDC-D10A and optional AOA pitot probe purchased from Dynon Avionics. Additionally, this guide deals with setting up the installation-dependant firmware options. Because you may not have purchased all the components, you need only read through the relevant sections of this guide. Information about the *operation* of this instrument can be found in the EFIS-D100 Pilot's User Guide.

The EFIS-D100 uses solid-state sensor technology to give an accurate and easy-to-understand display. To ensure accuracy in its readings, it is very important that you install the instrument correctly and perform the specified calibration steps. This installation guide will help you through that process.

OEM Installations

If your EFIS-D100 is installed by an OEM distributor, you may find that you are unable to access some menus and settings. Some Dynon distributors customize various areas of the EFIS-D100 firmware to maintain a consistent pilot experience and minimize integration issues across a large number of installations. Currently, OEMs can customize access levels to the following settings on Dynon systems: EMS GLOBAL setup menu, EMS SENSOR setup menu, fuel calibration, trim calibration, flaps calibration, GPS/NAV setup menu, screen configurations, data logging, and checklists/data panels. OEM distributors have the option of customizing some or all of these areas. Please contact your aircraft's manufacturer if you have any questions about how your unit has been customized.

Warning

Dynon Avionics' products incorporate a variety of precise, calibrated electronics. Except for replacing the optional internal backup battery in EFIS-based products per the installation guide, our products do not contain any field/user-serviceable parts. Units that have been found to have been taken apart may not be eligible for repair under warranty. Additionally, once a Dynon Avionics unit is opened up, it will require calibration and verification at our Woodinville, WA offices before it can be considered airworthy.



About this Guide

In the electronic (.PDF) version of this manual, page and section references in the Table of Contents and elsewhere act as hyperlinks taking you to the relevant location in the manual. The latest version of this manual is available on the Dynon Avionics website at docs.dynonavionics.com.

The following icons are used in this guide:

- HS34** Any text following this icon describes functionality available only with the HS34 HSI Expansion Module connected to your system.
- AP74** Any text following this icon describes functionality available only with the AP74 Autopilot Interface Module connected to your system.
- DSAB** Any text following this icon describes functionality that is possible when multiple Dynon Avionics products are networked together via the Dynon Smart Avionics Bus (DSAB).
-  Any text following this icon refers to a setting or situation which merits particularly close attention.

Menu Descriptions

Throughout this guide, the “>” character is used to indicate entering a deeper level of the menu system. For example, “EFIS > SETUP > VRSION” indicates entering the EFIS menu, pressing MORE, then pressing SETUP, and then pressing VRSION to enter the firmware version menu. Note that the MORE button is not shown in the sequence, since pressing MORE reveals more options in the same level of the menu system.

2. WIRING OVERVIEW

Please follow these instructions explicitly as improper wiring can result in permanent damage to your instrument and/or the accompanying sensors.

All electrical power and EFIS-specific lines interface with the EFIS-D100 via the female 25-pin D-sub connector on the back of the instrument. Ensure that the unit powers on and that all indicators display expected values before completing the final physical assembly.

Recommended Wiring Practices

- ❗ For all electrical connections, use correct wiring techniques, taking care to properly insulate any exposed wire. A short circuit between any of the wires may cause damage to the EFIS-D100 and/or your aircraft. Make all connections to your harness before plugging it into any of the components of the system. Do not make connections while power is applied at any point in the system.

Dynon Avionics sells a wiring harness for all connections to the EFIS-D100. The harness is made up of 22 AWG wire and meet Mil Standard MIL-W-22759/16 (Tefzel insulation). If you have opted not to purchase this harness, please refer to the provided wiring diagrams for construction information. We recommend that all wire you use also meets Mil Standard MIL-W-22759/16; all wire supplied by Dynon Avionics (with the exception of thermocouple wire, which uses FEP insulation) meets this specification.

When using *any* pre-manufactured harness, verify that each pin has continuity with the expected wire on the wiring diagram. This test can be easily done with a multimeter. When verifying harnesses, use the wiring charts and diagrams in this guide as your ultimate authority on pin function (for any harness) and wire color (for harnesses purchased from Dynon Avionics).

Route all wiring such that there are no spots where it could chafe or break. Use appropriate strain relief at all junctions between wires and connectors. We recommend that you secure all wires at regular intervals along wiring runs to accommodate vibration effects.

All connections on the EFIS female 25-pin harness are described in the Instrument Installation section on page 3-1.

Power Requirements

22 AWG wire is normally sufficient for the power supply and ground lines, but we recommend that you consult a wire sizing chart and determine the size required for the wire routing in your particular aircraft. Ensure that the power lines include a circuit breaker or an appropriately sized fuse for the wire you select. Power is fed to the EFIS-D100 via pins in the female D-25 connector as shown on the 25-Pin Female EFIS Harness diagram on page 2-2.

The EFIS-D100 system-wide power requirement is **12 watts** typical and **17 watts** maximum. On a 12-volt system, this translates to about 1.5 amps of maximum current draw. On a 24-volt system, this translates to about 0.75 amps maximum current draw. Normally, a 3-amp circuit breaker or fuse is sufficient.



25-Pin Female EFIS Harness

Below is the wiring diagram of the EFIS 25-pin female harness. If you purchased your harness from Dynon Avionics, it is color coded according to the chart on the following page. Unless noted otherwise, all wires are 3 feet long on the Dynon-provided harness.

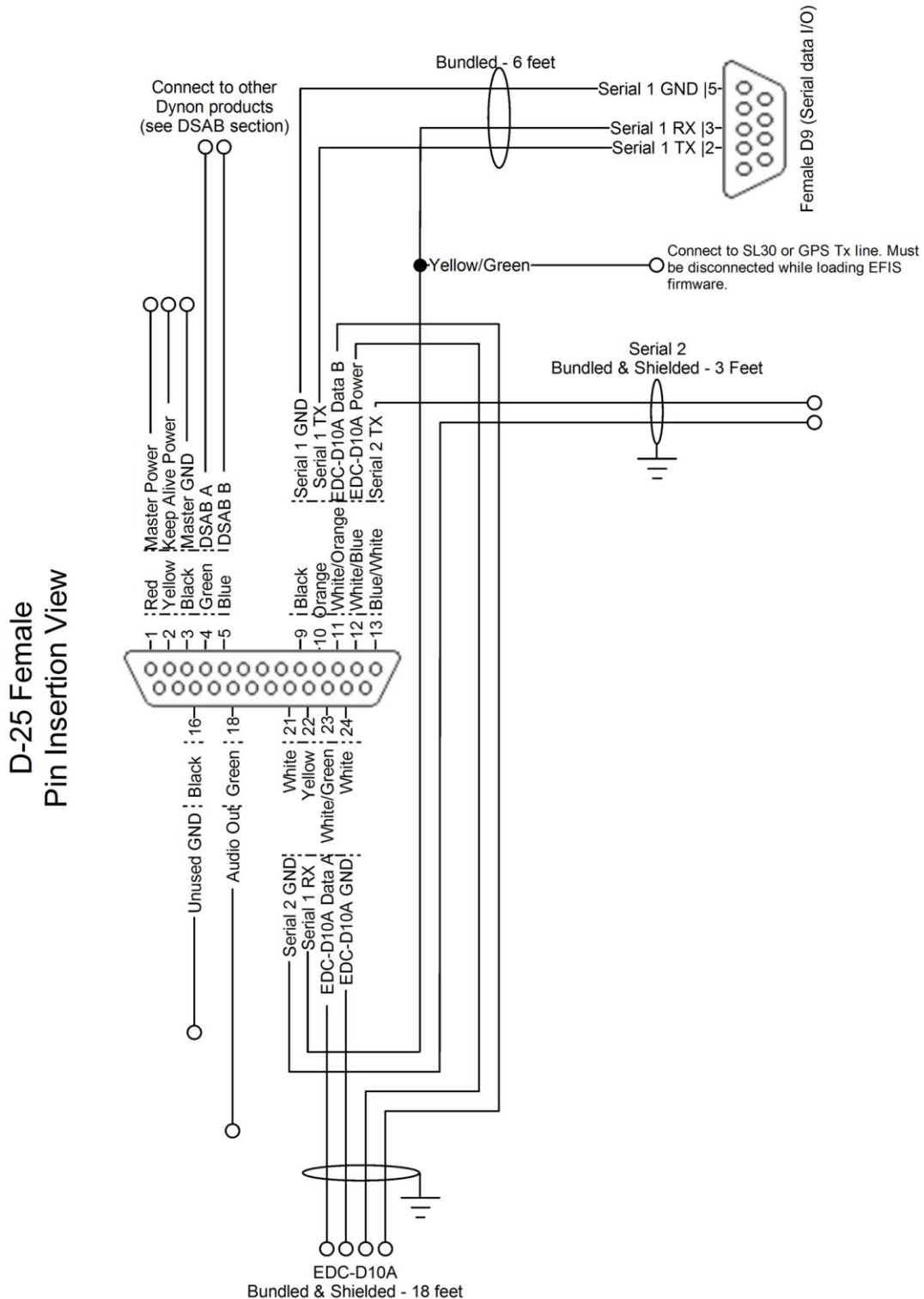



The pin assignments for the female 25-pin harness are repeated below. *Note that the pin numbers are labeled on the face of both the female and male connector.* Each connection on the harness supplied by Dynon is color-coded. These colors are listed in the following chart.

Female DB25 Pin #	Dynon Harness Wire Color	Function	Details
1	Red	Master Power (10-30 volts)	Page 3-3
2	Yellow	Keep Alive Power (10-30 volts, always on)	Page 3-3
3	Black	Master Ground	Page 3-3
4	Green	DSAB-A	Page 3-11
5	Blue	DSAB-B	Page 3-11
6	N/A	No Connect	
7	N/A	No Connect	
8	N/A	No Connect	
9	Black (bundled)	PC Serial Ground	Page 3-4
10	Orange (bundled)	EFIS-D100 Transmit / PC Serial Receive (RS-232)	Page 3-4
11	White/Orange (Red on some harnesses)	EDC-D10A Data B	Page 3-1
12	White/Blue (Black on some harnesses)	EDC-D10A Power (12V)	Page 3-1
13	Blue/White (black on some harnesses)	Serial Encoder Transmit (RS-232)	Page 7-32
14	N/A	No Connect	
15	N/A	External Backup Power	Page 3-3
16	Black	Ground	
17	N/A	No Connect	
18	Green	Audio out	Page 3-10
19	N/A	No Connect	
20	N/A	No Connect	
21	White (Bundled in Encoder cable)	Serial Encoder Ground	Page 7-32
22	Yellow (Bundled)	EFIS-D100 Receive / PC Serial Transmit (RS-232)	Page 3-4
23	White/Green (Green on some harnesses)	EDC-D10A Data A	Page 3-1
24	White	EDC-D10A GND	Page 3-1
25	N/A	No Connect	



WIRING SYSTEM OVERVIEW

The following block diagram depicts the basic layout of the EFIS DB25 electrical connections and is for reference only. Read the specific instructions for each connection prior to installation. The colors shown refer to the Dynon-supplied EFIS harness.

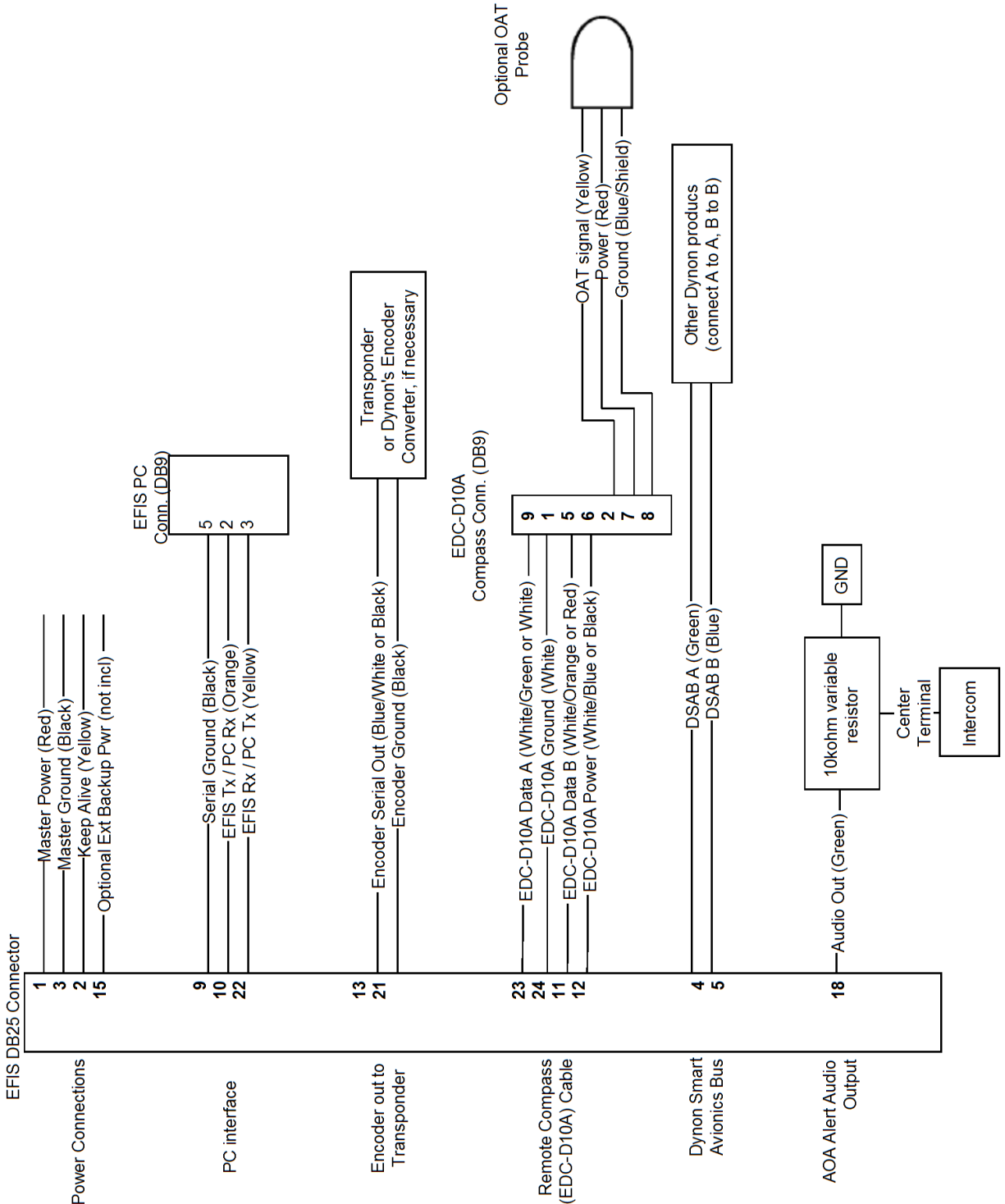

3. INSTRUMENT INSTALLATION

This section provides you with the information needed to physically and electrically install the EFIS-D100.

Selecting a Remote Compass Module Location

Finding a good location for the EDC-D10A remote compass module is critical to an accurate EFIS-D100 heading display. Keep in mind that calibration can compensate for small static magnetic fields superimposed upon the earth's field; it cannot take into account dynamic effects like AC currents, non-constant DC currents and non-stationary ferrous material (e.g., an electric turn coordinator). Use the following suggestions to help you find a good location for your EDC-D10A.

- Keep the EDC-D10A away from any source of magnetic fields (such as electrical equipment and current-carrying wires) and ferrous material.
- Move a handheld compass throughout the space surrounding your location to get a rough idea of the suitability of your chosen location. If the needle deviates significantly from magnetic north in any given area, that location would not be ideal for the EDC-D10A.
- The EDC-D10A can be mounted anywhere in the aircraft (away from magnetic interference) such that its pitch is as close to that of the EFIS-D100 as possible. It does not need to be directly along any axis of the EFIS-D100. It should be mounted with the long axis parallel to the wings, the electrical connector facing toward the front of the plane, and the mounting tabs on the bottom. The bracket used to hold the EDC-D10A must hold the EDC-D10A at the same pitch, roll, and yaw as the EFIS-D100 with respect to the airframe. We recommend that you use an electronic level, if available, to make sure

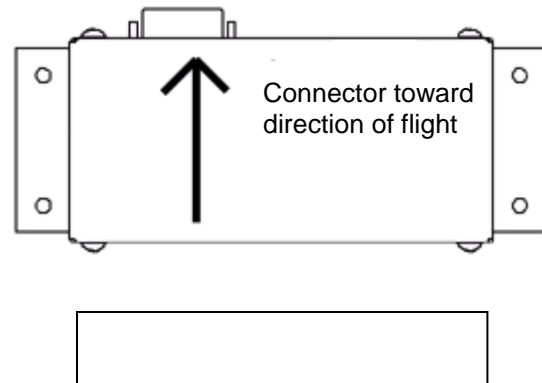
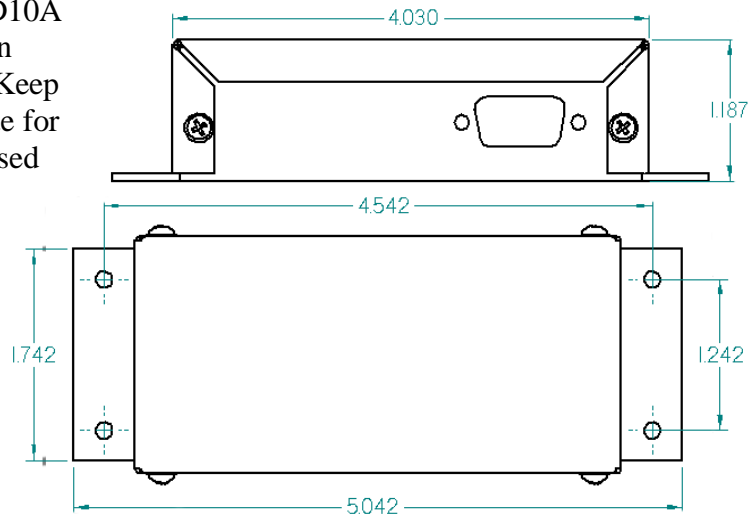

Connector forward and tabs mounted down

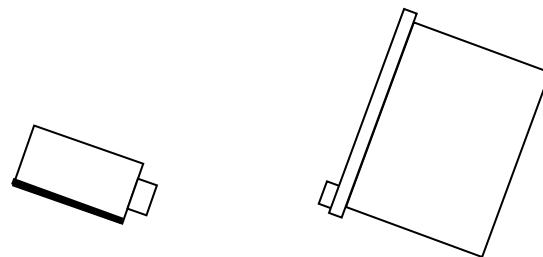

Side view of EDC-D10A, tabs mounted down and aligned within 1 degree of pitch with EFIS-D100



the EDC-D10A is aligned with the EFIS-D100 to better than 1 degree.

- All mounting hardware needs to be made from non-ferrous material such as aluminum, plastic, or brass. Many stainless steel screws are magnetic. If the item is attracted to a magnet, it should not be used in the installation. The EDC-D10A needs to be mounted in a location as free from magnetic interference as possible. This means keeping the EDC-D10A away from any ferrous nuts, bolts, and screws, aircraft tubing, as well as from wires or devices carrying any appreciable current such as strobe light wiring, autopilot servos, or other electronics.

EDC-D10A Communication Cable

- ❗ DO NOT ATTEMPT TO POWER UP THE EFIS-D100 WITH THE EDC CABLE LEADS EXPOSED (UNSHEATHED) AND NOT INSTALLED IN THE DB9 CONNECTOR. SHORTING THESE CONNECTIONS WILL CAUSE DAMAGE TO THE UNIT.

Like the RS-232 PC Communication cable, the EDC-D10A communications cable terminates in a standard female DB9 connector. While they look similar, do *not* plug the EDC cable into a PC or vice versa. The following table outlines the four connections that must be made to ensure proper communication between the EFIS-D100 and the EDC-D10A remote compass module. The Dynon-supplied harness colors are listed, as well.

EFIS DB25 pin#	EDC DB9 pin#	Function	Wire color
11	5	EDC Data B	White/Orange (or Red)
12	6	EDC Power	White/Blue (or Black)
23	9	EDC Data A	White/Green (or Green)
24	1	EDC Ground	White

The EDC cable in the harness supplied by Dynon consists of 4 conductors, surrounded by a metal shield and white insulation. These 4 wires are terminated with crimped female D-sub pins wrapped in plastic tubing. If you are building your own cable, we recommend that you use shielded cable as well.

- With the 25-pin EFIS harness disconnected from the EFIS-D100, carefully cut or pull the tubing off the 4 D-sub pins.
- Route the cable to the EDC-D10A mounting location chosen according to the instructions above.
- Install the female pins in the correct holes on the included DB9 connector, according to the chart above. **Note that Dynon has shipped harnesses with different colors for the EDC cable;** determine your connections using the two sets of colors in the table above.
- Install the back shell around the DB9 connector.

Correct wiring installation can be easily verified once completed. Power on the EFIS-D100 with the EDC-D10A connected to it. If you have correctly wired your EDC-D10A wiring harness you will see the heading properly displayed at the top of the screen (provided you have turned on the heading display in the CLUTTR menu). If wiring is not correct, or the EDC-D10A is not



communicating properly with the EFIS-D100, you will see the message REMOTE COMPASS NOT DETECTED in place of the heading onscreen.

The metal shield around the EDC communication cable is connected to the short black/white wire emanating from the DB25. Connect this wire to ground.

Power Inputs

The EFIS-D100 has three separate power inputs, located on the DB25 EFIS connector. Of the three, only Master Power is required to operate the instrument. The other two inputs provide redundancy. Below is a table that explains the three inputs and their purposes. All three of these inputs share a common ground signal, wired to pin 3 on the EFIS connector.

EFIS DB25 pin#	Function	EFIS DB25 wire color	Description
1	Master Power	Red	Provides primary power to the instrument. The EFIS-D100 will switch on upon application of power. Connect to a switched power source. Will not be adversely affected by engine cranking.
2	Keep Alive Power	Yellow	A very low current power input which is only used if both Master and External Backup Power are not applied. Keep Alive draws just enough current to keep the clock running. It draws less than 1 milliamp of current when not charging the internal backup battery. Dynon Avionics recommends not connecting the Keep Alive wire when the EFIS-D100 has an internal battery installed or is connected to a GPS. Keep Alive is only used in installations with no battery or GPS to keep the clock running when the unit is powered off.
3	Master Ground	Black	Connect to ground. Must carry as much as 3 amps.
15	External Backup Power	(Not wired in Dynon harness)	Will operate the EFIS-D100 only if Master Power is not present. The transition from Master Power to External Backup Power will bring up a warning, requiring you to press ACK within 30 seconds to keep the unit operating. This warning will also display when transitioning from either Master or External Backup to Internal Battery power.



Serial Communication Cable

! **More Information Is Available Online:** Serial communication to non-Dynon devices, and interfacing of other devices in general can be involved and detailed. This Installation Guide is intended to provide general installation advice for the most common devices and situations. Dynon’s Documentation Wiki provides enhanced, extended, frequently updated online documentation contributed by Dynon employees and customers at wiki.dynonavionics.com.

The EFIS-D100 has one RS-232 serial port that can be used for several purposes. This serial port can only be configured for one purpose at a time.

The EFIS Serial port (DB25) is used for:

- Connecting to a PC, and using the Dynon Avionics Product Support Program to perform firmware upgrades, configure checklists, and download internal logs. The Help Files of the Support Program provide detailed instructions on these functions. The latest version of the Product Support Program is available on the Dynon web site at downloads.dynonavionics.com.
- Connecting serial devices such as a GPS receiver or an SL30.
- “Streaming” real-time EFIS flight data to an external serial device for recording. For data formats and other information, see the Appendix in the EFIS-D100 Pilot’s User Guide. Note that for the purposes of logging data, version 5.0 of EFIS-D100 firmware added internal data logging and retrieval via the Dynon Product Support Program.

HS34 When an optional HS34 Expansion Module is connected to your Dynon DSAB network, all GPS and NAV radios must be connected to it. This simplifies the connection and usage of multiple serial devices. The HS34 also provides interfaces to non-serial devices such as those with only analog and ARINC-429 interfaces.

PC USB CONNECTION

If you do not have a serial port on your PC, use the included USB-to-Serial adapter to connect the EFIS-D100 to your PC’s USB port. If you are using **Windows 2000 or XP**, ensure that the adapter driver CD is inserted in your PC before plugging the adapter into the USB port for the first time. If you are using **Windows Vista**, ensure that you are connected to the Internet and do *not* use the driver CD; the operating system will download the correct driver. Also, do not have your EFIS-D100 plugged into the USB-to-Serial adapter while installing the driver.

EFIS SERIAL HARNESS

On the EFIS 25-pin wiring harness available from Dynon, there are three wires bundled together, terminating in a standard DB9-pin female connector. This cable is 6’ long and pre-assembled for connection to a PC-based laptop. Route this cable to a convenient location that can

EFIS DB25 Pin#	DB9 Pin#	Wire Color	RS-232 Function
9	5	Black	Signal ground
10	2	Orange	EFIS-D100 transmit / device receive
22	3	Yellow	EFIS-D100 receive / device transmit



be accessed whenever you need to update your product’s firmware or checklists.

If you did not purchase a harness from Dynon, obtain a 9-pin D-sub connector and make the three connections shown in the table.

To verify proper communication between the EFIS-D100 and the PC, use the Dynon Avionics Product Support Program’s “Detect Firmware Version” function. Download the latest version of the Support Program from the Dynon Web Site at downloads.dynonavionics.com.

SL30 and/or GPS connection

Depending on the number and types of Dynon units you own, you have several options for connecting a GPS unit and/or Garmin/Apollo SL30 to your Dynon system. The GPS can be used as a data source for the EFIS, HSI, and Fuel pages, as well as Dynon’s EFIS-based Autopilot. The SL30 can be used as a VOR, localizer, or ILS (localizer + glideslope) source for the HSI. If you wish to connect a GPS and/or SL30 to your Dynon system, read the section below which corresponds to your set of Dynon products.

HS34 If your system has an HS34, it is *required* that all GPS and NAV devices are connected to the HS34. The EFIS-D100 does not support directly connected GPS and NAV devices when an HS34 is installed in the system. Refer to the HS34 Installation and Configuration section on page 7-10 for device connection details.

To use the GPS-related features on your EFIS and/or EMS, your GPS must output either “aviation format” or the following NMEA sentences in its serial stream: \$GPRMC, \$GPRMB, \$GPGGA, and one of \$GPBOD or \$GPAPB. You must also have a supported cable that exposes your GPS’s serial transmit line. If you own a Garmin 430 or 530, in the UNITS/MAGVAR option, set the MAGVAR to AUTO. The EFIS-D100 auto-detects most GPSs, but may require a manual setting for some. This is true for communication with at least the Garmin 480 and maybe others such as the GX50, and GX60, and Bendix/King Skymap IIIc. From the EFIS menu, enter SETUP >HSI >EFIS_SERIAL; from the EMS menu enter SETUP >GLOBAL >EMS SERIAL. In that menu select the INPUT to be AVIATION and the BAUD RATE to be 9600.

The following connection schemes assume that the external devices share a common ground

GPS units known to work
AvMap EKP-IV (v2.06.116R, NMEA set to “processed”)
Bendix/King Skymap (set to AR NAV 9600 output)
Garmin 96, 96c, 150XL, 195, 196, 295, 296, 396, 400*, 420*, 430*, 430W*, 496, 500*, 520*, 530*, 530W*, GX60, GX65
Lowrance handhelds
<i>* Do not output time over serial; ARINC connection via HS34 required to receive time.</i>
<i>A frequently updated list of compatible GPS units and settings is available at our Documentation Wiki at wiki.dynonavionics.com.</i>

GPS units with limited functionality	
AnywhereMap	Does not output all needed sentences. Time output is wrong.
Garmin (Apollo) GNS 480	Possibly works with latest Dynon product firmware, but untested. Requires manual configuration. See note at left. Fully compatible via ARINC into optional HS34.
<i>A frequently updated list of compatible GPS units and settings is available at our Documentation Wiki at wiki.dynonavionics.com.</i>	



with the Dynon product(s). If your GPS is battery powered, and not normally connected to aircraft ground, you must connect the ground pin on its serial output to a ground common to the EFIS-D100.

When a Dynon product is connected to a GPS, it will synchronize its Zulu clock to the time reported by the GPS. However, some GPSs, such as the Garmin 430 and 530, do not report time in their serial output stream. Dynon products have no way to synchronize to these GPSs' clocks.

Read the section below that corresponds to your configuration of Dynon products. All EFIS-based product configurations direct you to connect your external device to PC serial receive (pin 22) on your Dynon EFIS product. You may make this connection at any point between pin 22 on the EFIS DB25 and pin 3 on the connected DB9 EFIS/PC connector. If you purchased your harness from Dynon Avionics, it may have a yellow/green wire provided for this purpose.

IF YOU OWN ONLY AN EFIS-D10A OR EFIS-D100

Connect the GPS or SL30 transmit line into pin 22 on the DB25 connector. This is the same Serial Rx line that is used for firmware updates. You will need a way to disconnect this when you plug your EFIS into a PC for firmware updates and checklists.

If you have both a GPS unit and an SL30, you will need to wire the two transmit lines to a 3-way switch; connect the output of the switch into pin 22 on the EFIS harness. You will use this switch to toggle between GPS, SL30 and a disconnected state. The HSI auto-detects the switched instrument and will change modes automatically.

IF YOU OWN TWO EFIS-ONLY UNITS

When 2 EFIS-only units are connected via DSAB, only the DSAB Bus Master's serial port is active.

If you have only one serial device (GPS or SL30), connect its transmit line to pin 22 on the DB25 connector of the EFIS that you have chosen to be the Bus Master. This is the same Serial Rx line that is used for firmware updates. You will need a way to disconnect this when you plug your EFIS into a PC for firmware updates and checklists.

If you have both a GPS unit and an SL30, you have two options:

- Wire the 2 devices' transmit lines to a switch, allowing you to select the serial device active on the HSI screen.
- Do not connect the two EFIS units together via DSAB. You may then wire one device to one EFIS' pin 22, and the other device to the other EFIS. Of course, the EFIS devices would be independent and unable to share GPS or SL30 data.

You will need a way to disconnect both lines when you plug your EFIS into a PC for firmware updates and checklists.

IF YOU OWN ONLY AN EMS-D10 OR EMS-D120

We recommend that you only connect a GPS to an EMS-only system; without the magnetic heading from an EFIS, the HSI page will not be functional. Connect the GPS transmit line to pin 19 on the EMS DB37 connector. This connection will give you fuel endurance information



(range, MPG, etc) on the fuel page and GPS information only (track, ground-speed, course, etc) on the HSI page. There is no need to break this connection when doing PC updates.

IF YOU OWN AN EMS AND AN EFIS (NOT FLIGHTDEK-D180)

First, ensure that your EMS and EFIS are connected as described in Dynon Smart Avionics Bus (DSAB) Wiring on page 3-11.

If you only have either the GPS or SL30 (but not both), connect the GPS or SL30 transmit line to pin 19 on the EMS DB37 connector. This is labeled “Aux Serial Receive.” With either a GPS or an SL30 connected, you are able to display an HSI on either product; with a GPS connected, you are able to display EMS fuel economy displays.

If you have a GPS *and* an SL30, connect the GPS to pin 19 on the EMS DB37 connector. Connect the SL30 to pin 22 on the EFIS DB25 connector. This will allow you to flip between GPS and SL30 inputs. You can use either the SL30 or GPS as the NAV source on the EFIS product. You will need to disconnect the SL30 from the EFIS when doing software updates.

IF YOU OWN ONLY A FLIGHTDEK-D180

Connect the SL30 unit to pin 22 on the EFIS DB25 connector, and the GPS to pin 19 on the EMS DB37 connector. You can display either source on the HSI using the softkeys. You will need to disconnect the SL30 from the EFIS when doing software updates.

IF YOU OWN A FLIGHTDEK-D180 AND AN EFIS

Connect the SL30 unit to pin 22 on the FlightDEK’s EFIS connector (vertical DB25) and the GPS to pin 19 on the EMS DB37 connector. You can display either source on the HSI, and you can display either on the standalone EFIS as well (provided you have connected the DSAB A & B lines from the FlightDEK-D180 to the standalone EFIS product). You will need to disconnect the SL30 from the FlightDEK-D180 when doing software updates.

Do not connect any serial devices to the secondary EFIS device. It will only display data from the serial devices connected to the master FlightDEK-D180.

Altitude Encoder Wiring

The EFIS-D100 outputs its altitude measurements in one of four standard serial outputs and is readable by many modern transponders. The EFIS-D100 will function properly whether or not this altitude encoder functionality is used. To use the EFIS-D100's altitude encoder functionality, simply wire the 2 encoder connections (GND and Encoder Transmit) from the DB25 connector to their respective connections on your transponder.

Per ATC/FAA requirements, the serial encoder output of the EFIS-D100 reports pressure altitude, which, by definition, is indicated altitude when the baro is set to 29.92. So, when you set your EFIS-D100's baro adjustment to 29.92, its indicated altitude will match the altitude that is being reported to your transponder.

There are four different serial formats used by transponders. The EFIS-D100 can output any of these formats. To select which format the EFIS-D100 sends out its serial encoder output port, you must choose the appropriate format via the menu system. When the menu system is displayed, push the following sequence of buttons: MORE > SETUP > MORE > ALTENC. When in the Altitude Encoder Setup menu, you can toggle the resolution of the output between 10 and 100 feet; this accommodates some transponders which can input and display altitude in 10 foot increments. In this menu, you can also select between the four different output formats, which are described below.

Dynon's supplied EFIS harness has a serial altitude encoder cable which consists of 2 conductors, surrounded by a metal shield and white insulation. Dynon has shipped harnesses with different colors for Encoder serial transmit line. Determine your connections using the table above. Connect the Encoder serial transmit to your transponder's serial input or to Dynon's Serial-to-Parallel Converter as described in the Encoder Serial-to-Gray Code Converter Installation section on page 7-32 in the Appendix.

If your transponder requires parallel Gray code input, and you wish to use the EFIS-D100 as your altitude encoder, you will need to purchase Dynon Avionics' Encoder Serial-to-Parallel Converter. Please refer to page 7-32 for more information on the installation of this option.

EFIS DB25 pin#	Function	Wire color
13	Encoder serial transmit	Blue/White (or black)
21	Ground	White



SERIAL ALTITUDE FORMATS

There are four formats used by serial transponders. Choose the correct format for your transponder in the ALTENC menu, using the FRMAT button.

Format 1

Used By	Dynon Encoder Serial-to-Parallel Converter , Garmin AT (formerly UPS Aviation Technologies)
Baud rate	1200
Format	#AL, space, +/-sign, five altitude bytes, T+25, checksum, carriage return
Example message	#AL +05200T+25D7[CR]

Format 2

Used By	Magellan
Baud rate	1200
Format	\$MGL, +/- sign, five altitude digits, T+25, checksum, carriage return
Example message	\$MGL+05200T+25E3[CR]

Format 3

Used By	Northstar, Garmin
Baud rate	2400
Format	ALT, space, five altitude bytes, carriage return
Example message	ALT 05200[CR]

Format 4

Used By	Garmin GTX330 (set on Icarus input), Garmin GTX327 (set on Icarus input), Garmin GTX328 , Icarus, Trimble
Baud rate	9600
Format	ALT, space, five altitude bytes, carriage return
Example message	ALT 05200[CR]

Audio Alert Output

The EFIS-D100 has an audio alert output for sounding AOA and altitude alarms through an intercom or audio panel.

DB25 pin#	Color	Function
18	Green	EFIS Audio Alert Output

HS34

AP74

If you have purchased and installed an HS34 and/or an AP74, we recommend that you only connect the HS34 audio output *or* AP74 audio output (but *not* both) to your audio panel. The HS34 or AP74 audio output provides voice and tone outputs for both EMS- and EFIS-related alerts. When the HS34 or AP74 audio output is connected, it is not necessary to connect the audio outputs of other Dynon Avionics devices. Connecting the HS34 audio output and the AP74 audio output in parallel *will result in distorted audio*. Refer to the HS34 Wiring section on page 7-10 for more information.

Connect the alarm output from the EFIS-D100 to the outside terminal of a 10 k Ω variable resistor (not included). Ensure that audio outputs are connected similar to the following diagram. The 10 k Ω variable resistor can be obtained from Radio Shack (P/N 271-1715) or other electronics suppliers.

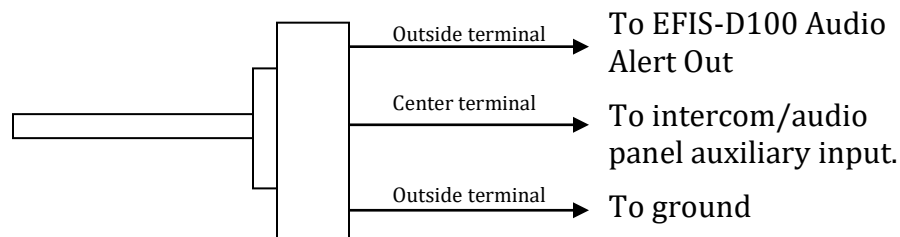

To set the volume of the AOA alarm, you will need your EFIS-D100 powered on and the alarm output wired as described above. Enter the EFIS menu by pressing any button (except the leftmost or rightmost) beneath an EFIS page. Press MORE > SETUP > MORE > MORE > MORE > AOAALM. In that menu, press the TEST button. While the button is held down, the AOA alarm will sound. Adjust the variable resistor until the volume in the intercom or audio panel is at an acceptable level.

Dynon Smart Avionics Bus (DSAB) Wiring

The Dynon Smart Avionics Bus is the only way Dynon products can communicate with one another, providing features such as data sharing and alarm notification. DSAB is a multi-drop bus, meaning several devices can be connected to the same 2 wires. If you have an EMS and EFIS product connected via their serial ports through a null modem, you should disconnect this legacy interface.

EFIS DB25 pin#	Function	Wire color
4	DSAB-A	Green
5	DSAB-B	Blue

You must connect the DSAB A connection (pin 4) on the EFIS DB25 female harness to the DSAB A connection for the next device in the chain. Do likewise for the DSAB B connection (pin 5). Some products – like the EFIS series and the HS34 – have only one pair of DSAB connections on the back connector; other products – like the EMS series – have two pairs, for wiring convenience. If you have 3 or more devices in your system, and one of them is an EMS-series product, we recommend that you locate it in the middle of your wiring scheme as shown below. This eliminates the need to splice two wires together.

- ⚠ Wherever possible, ensure that the two DSAB wires (DSAB A and B) are run as a twisted pair. This minimizes the system's susceptibility to electrical noise.

Refer to the DSAB Configuration chapter on page 5-1 for detailed instructions on configuring your DSAB network.

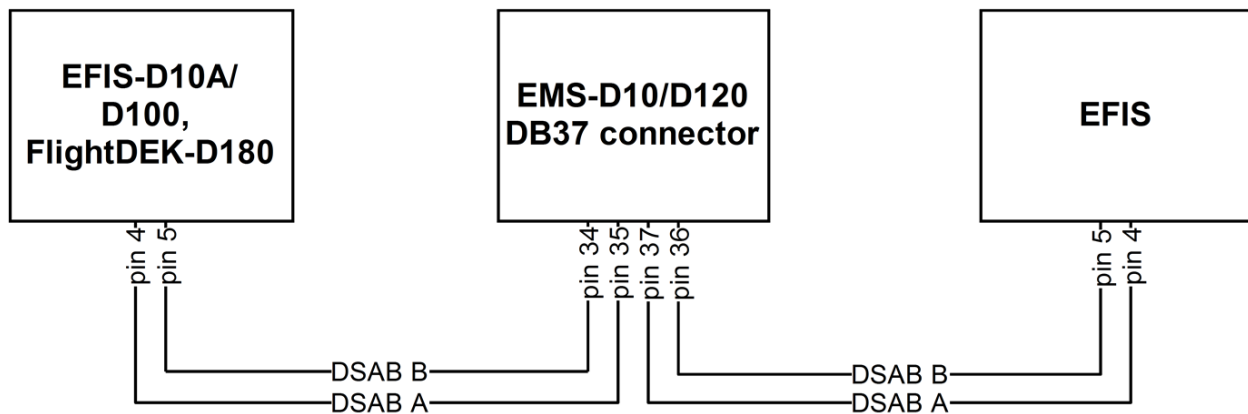



Panel Location and Mounting

The diagram below shows the outside dimensions of the front bezel of the EFIS-D100. Note that the instrument and tray extend about 4.5” behind the panel, and the supplied harness extends three inches more. Use the dimensions (in inches) found on the diagram to plan for the space required by the instrument. Take the following considerations into account when selecting a mounting location for the EFIS-D100.

Avoid placing the instrument near heater vents or any source of extremely hot or cold air. Keep in mind that the air surrounding the EFIS-D100 during operation may be no warmer than 50 °C. Plan a panel location that allows convenient viewing of the instrument with no obstruction. When flying straight and level, the panel angle from vertical may not be greater than +/- 30 degrees. The unit must also be parallel to the roll axis of the aircraft (although not necessarily located along it), and have no significant roll angle in the panel. The firmware supports an adjustment for panel tilt, but not for mounting errors in yaw or roll. Correct attitude performance depends on mounting the EFIS-D100 square with the direction of flight.

To mount the EFIS-D100, you must make a rectangular cutout in your panel. Ensure that the dimensions of the cutout are: **6.780” wide and 4.750” tall**. Place the D100-series mounting tray behind the cutout. Secure it to your panel in whatever way you desire. Riveting it to the panel is ideal, but drilling holes for mounting screws and nuts will work as well. You may cut off 2 horizontal or vertical tabs from the mounting tray to minimize the space taken up behind the panel. Upon securing the mounting rack to the back of your panel, slide the EFIS-D100 into it. Use the included 7/64” Allen wrench to secure the mounting screw (at the bottom left of the front bezel) into mounting rack. At your discretion, you can also screw a #6-32 screw into the back of the mounting rack on the opposite side. This screw should penetrate into the instrument no further than 1/4”.

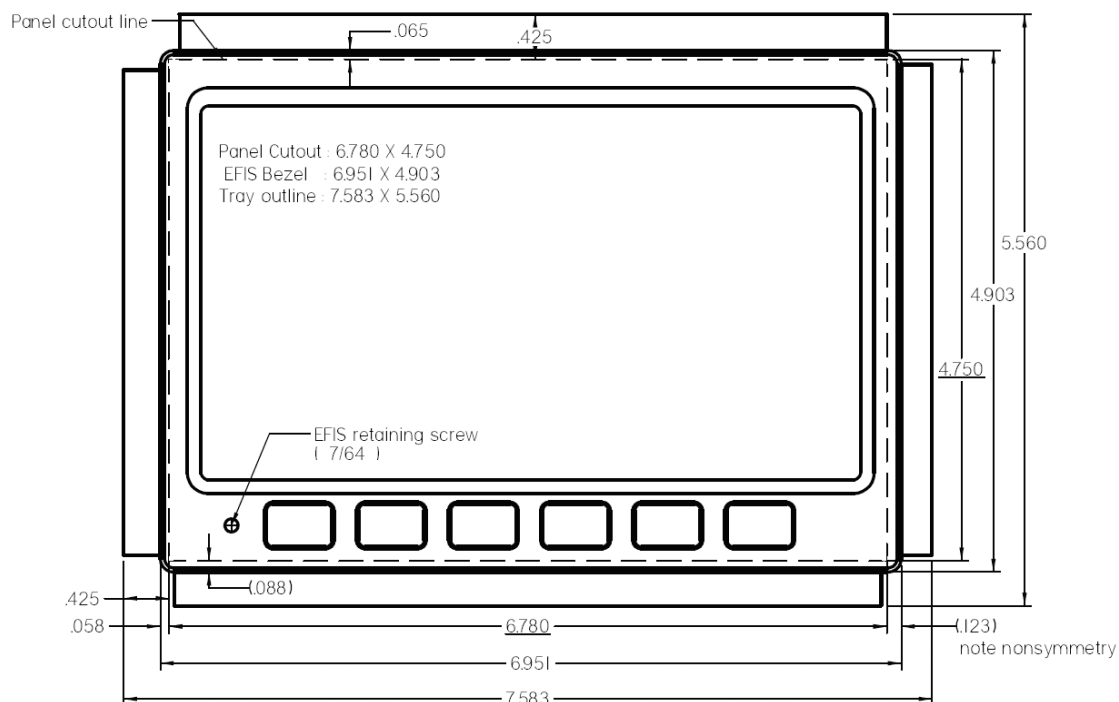



Connecting Static & Pitot Lines

The AOA, pitot, and static ports on the back of the EFIS-D100 are equipped with 1/8" NPT Female fittings. To attach your pitot and static lines to the back of the EFIS-D100, you must use standard 1/8" NPT Male fittings at the end of each of the lines.

To install, simply connect your static and pitot sources to the EFIS-D100, T'ing off of existing lines if performing a retrofit. View the following back view diagram the placement of your pressure lines.

The EFIS-D100's attitude calculation requires either airspeed (from pitot and static) or GPS data. To ensure proper operation, at least one of these data sources must be available. We recommend the EFIS-D100 be connected to pitot and static

Use a wrench to secure the mating pressure line fittings to the corresponding locations on the back of the EFIS-D100. Do not over-tighten.

If you purchased Dynon's AOA pitot tube, note that it has pitot and AOA ports on it, but not static. You will need to provide your own source of static pressure for the EFIS-D100 and any other instrument in your panel which requires it.

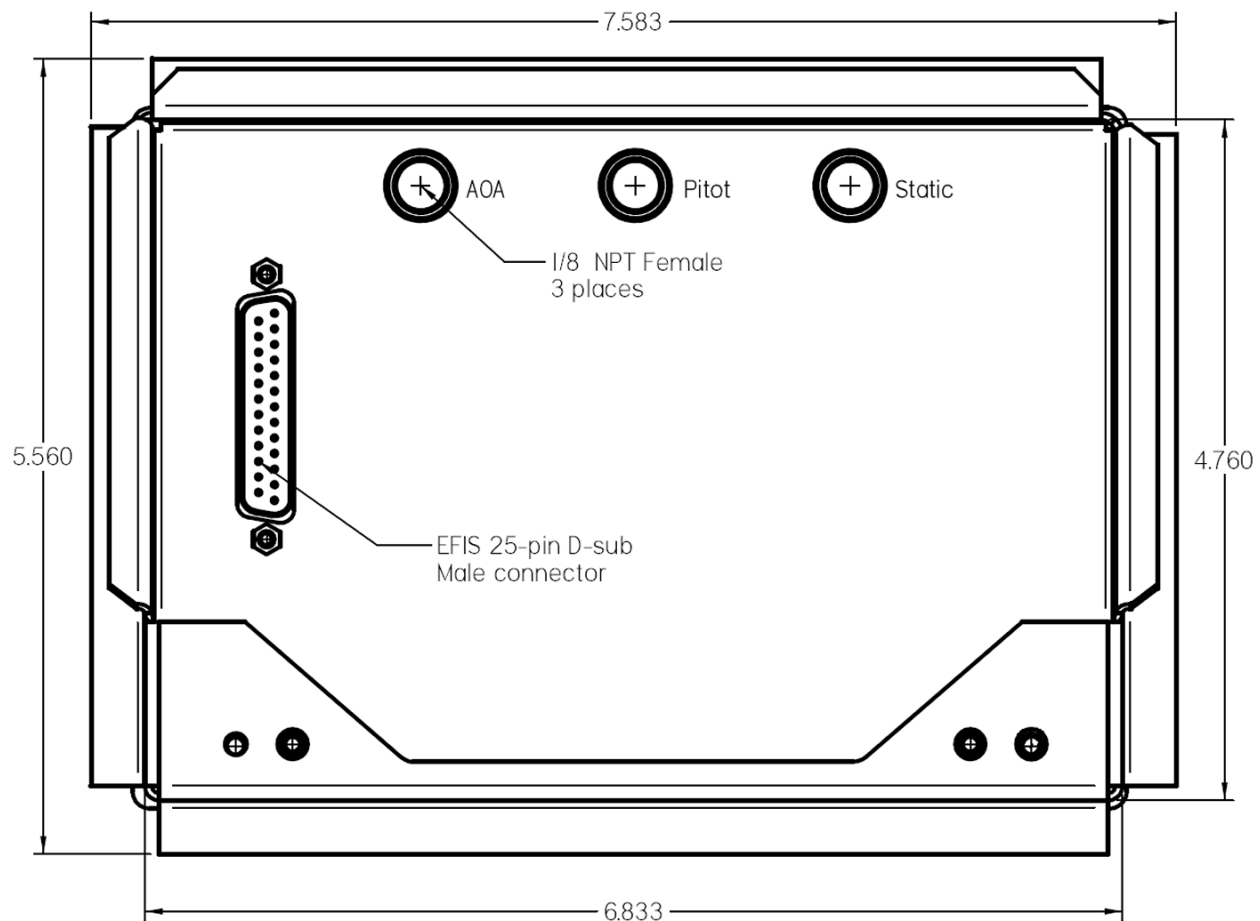

4. EFIS CALIBRATION AND CONFIGURATION

During manufacture, your EFIS-D100 underwent a comprehensive calibration, verification, and burn-in routine that minimizes setup time and ensures that your EFIS meets Dynon's stringent performance specifications. To account for your individual preferences and your aircraft's particular setup, there are a few simple calibration and configuration steps that you must complete before using your EFIS-D100. This section takes you through these steps to make sure that you have properly installed and configured your EFIS-D100.

- ⚠ **CAUTION:** It is your responsibility to fly your plane safely while performing any configuration or calibration in flight. The best scenario would include a second person to perform any necessary steps on the unit.

Ensuring Proper Installation

Turn your unit on by energizing the aircraft power to which it is connected. Ensure that the screen is bright and readable and that all instrument displays appear. *If a desired display item is not present, refer to the User's Guide to use the CLUTTR feature to display the missing item.*

Setting Zero Pitch (In flight)

- ⚠ For the purposes of this setting, level is defined as the attitude at which the aircraft's longitudinal axis is parallel to the ground. For most aircraft, the attitude the aircraft assumes at normal cruise speeds will be acceptable. Additionally, this feature should not be used to "zero out" pitch when the aircraft is at an attitude other than level. Do not think of this adjustment as you would the parallax adjustment on a normal attitude indicator. Instead, think of it as a calibration step which is not changed often.

With your aircraft flying straight and level, enter the EFIS > SETUP > PITCH menu. Press INC or DEC until the horizon line intersects the center of the crosshairs. It is important that this be done while the aircraft is level to ensure proper pitch and roll display throughout all maneuvers.

Compass Heading Calibration

This section guides you through the calibration and configuration of your magnetic heading indication. Prior to calibrating your EDC-D10A, you must configure the local magnetic inclination and magnetic intensity as described in the sections below.

- DSAB** In a DSAB network, the Bus Master's heading is used as the only heading source for all connected instruments. However, in the event of a DSAB failure, EFIS instruments revert to their local heading source. In a system already using a shared heading, you may still configure and calibrate the local heading source. As soon as you bring up any of the magnetic calibration menus (MAGINC, MAGCAL, MAGADJ, MAGINT), the heading and DG displays switch to display the locally-derived heading indication. The display stays on that source until exiting the magnetic configuration menu. If you do not have an EDC-D10A connected, REMOTE COMPASS NOT DETECTED is displayed when in any of these menus.

SETTING MAGNETIC INCLINATION ANGLE AND INTENSITY (REQUIRED)

- !** To calibrate your EFIS-D100 heading, you must input your location's current magnetic inclination angle and intensity. Before doing this, you must obtain these two values for the geographic location where you will be performing the calibration. Note that this procedure only needs to be done once, prior to magnetic calibration. *Moving the aircraft to another location does not require repeating this procedure.*

Obtaining Magnetic Inclination and Intensity

1. Browse to web page: www.dynonavionics.com/docs/maginfo.html. (Looking up this information does not have to be done on a computer at the plane, with live Internet access.)
2. The Dynon Avionics "Magnetic Inclination and Intensity" web page is updated as needed; it contains a link to a NOAA web pages and instructions for easily finding your local magnetic inclination and intensity by inputting your ZIP code (in the US) or your latitude and longitude and inputting the resulting data into your Dynon EFIS.
3. Follow the instructions listed on the web page, especially clicking the "Compute Magnetic Field Values" button at the bottom of the linked page – the values required by your Dynon EFIS will be displayed only after clicking that button. *If you are near the equator or in the southern hemisphere, note that the inclination may be negative number.*

Entering inclination and intensity into the EFIS-D100

1. Enter the inclination setup menu by pressing any button beneath an EFIS page (except the far left or far right hotkeys), then MORE > SETUP > MORE > MORE > MAGINC
2. Press INC or DEC to increment or decrement the displayed inclination angle. Press and hold to change values more rapidly.
3. When the display shows the magnetic inclination angle for your location, press BACK to leave the menu.
4. Enter the magnetic intensity setup menu by pressing any button beneath an EFIS page (except the far left or far right hotkeys), then MORE > SETUP > MORE > MORE > MAGINT
5. Press SEL to change the digit being incremented or decremented. Press INC or DEC to increment or decrement the selected digit. Press and hold to change values more rapidly.
6. When the display shows the magnetic intensity for your location, press BACK to leave the menu.

EDC-D10A HEADING CALIBRATION (ON GROUND ONLY)

The procedure for in-plane calibration of the EDC-D10A involves pointing the aircraft in four directions and taking data at each direction using the EFIS-D100. The EFIS-D100 will then perform some calculations to ensure an accurate calibration.

- ❗ During magnetic calibration, do not turn the power off on the EFIS-D100. This will cause any recorded compass calibration data to be lost; the calibration will need to be restarted.

To perform the calibration, you will need the following:

1. EFIS-D100 and EDC-D10A installed in aircraft.
2. Magnetic inclination angle and intensity properly entered into the EFIS-D100 per the section above.
3. An accurate method of aligning the aircraft with *magnetic* North, East, South, and West, such as an airport's compass rose.

Once you have the installation completed, have verified that your EDC-D10A communicates with the EFIS-D100 (i.e., you see the heading tape displayed on the EFIS main page), and have located a suitable place to perform the calibration, perform the following steps:

1. Turn on the EFIS-D100 and allow it to warm up for at least 15 minutes before performing the calibration.
2. Align the aircraft pointing magnetic North as closely as possible.
3. On the EFIS-D100, enter the menu system by pressing any button beneath an EFIS page (except the far left or far right hotkeys) and press MORE > SETUP > MORE > MORE > MAGCAL. You should see a menu that reads NORTH, EAST, SOUTH, and WEST. If you do not, then the EDC-D10A is not properly communicating with your EFIS-D100.
4. Press the NORTH button; you will see the message, COLLECTING DATA FOR NORTH along with a 15 second timer. Let the time run out before proceeding.
5. Align the aircraft pointing magnetic East as closely as possible.
6. Press the EAST button; you will see the message, COLLECTING DATA FOR EAST along with a 15 second timer. Let the time run out before proceeding.
7. Align the aircraft pointing magnetic South as closely as possible.
8. Press the SOUTH button; you will see the message, COLLECTING DATA FOR SOUTH along with a 15 second timer. Let the time run out before proceeding.
9. Align the aircraft pointing magnetic West as closely as possible.
10. Press the WEST button; you will see the message, COLLECTING DATA FOR WEST along with a 15 second timer. Let the time run out before proceeding.
11. Press the END button. This will cause the EFIS-D100 to pause as it calculates. This pause should last between 1-20 seconds. However, if the collected data is poor, this can take as long as 5 minutes. A message will be displayed onscreen: CALCULATING MAGNETIC CALIBRATION VALUES.

12. Wait for the message CALIBRATION COMPLETE before attempting to use the EFIS-D100 or remove power. Press BACK to leave the menu.

This completes the EDC-D10A calibration process. The process can be repeated as often as desired. The overall accuracy of the compass depends on the installation location (away from any ferrous materials or current carrying wires or devices), the installation alignment (aligned with the EFIS-D100 in pitch, roll, and yaw), and the calibration procedure (accurately aligning the aircraft with North, East, West, and South and having the correct magnetic inclination angle loaded into the EFIS-D100). If the compass performance is not adequate for your usage, we suggest that you investigate each of these factors and try to optimize your installation for each factor.

If the heading shown onscreen is off by a small, but constant amount, you can change a heading offset in the EFIS-D100 which will correct this. Orient your plane in a known direction, preferably on a compass rose at the airport. Navigate to the Heading Adjustment menu by pressing MORE > SETUP > MORE > MORE > MAGADJ. Increment or decrement the value of the heading offset until the EFIS-D100 heading corresponds to the direction in which your plane is pointed.

Troubleshooting

During the calibration process you may receive one of the following errors. Next to each one is the corrective action required.

Message	Corrective Action
WARNING: MAGNETIC INCLINATION NOT SET.	You have not entered the magnetic inclination into the EFIS-D100 yet. Please see the “Entering Magnetic Intensity and Inclination Angle” section
WARNING: MAGNETIC INTENSITY NOT SET.	You have not entered the magnetic inclination into the EFIS-D100 yet. Please see the “Entering Magnetic Intensity and Inclination Angle” section

Configure Airspeed Color Thresholds

To configure the airspeed bar color thresholds for your unit enter the EFIS > SETUP > IASCLR menu. This displays the Airspeed Color Threshold menu. In this menu, enter the values for five airspeed constants (V_{so} , V_{s1} , V_{fe} , V_{no} , and V_{ne}), each of which has its own button. Enter these values in units of knots, mph, or km/h depending on what airspeed units you are currently using (you may change the displayed airspeed units via EFIS > SETUP > UNITS > IAS).

Perform the following steps for each airspeed constant:

1. Press SEL to select the digit you wish to increment or decrement.
2. Press DEC- or INC+ to decrement or increment the selected digit.
3. Press BACK to return to the previous menu.



You will not be able to see some of the colors until the aircraft has achieved airspeeds in the range of each threshold.

5. DSAB CONFIGURATION

This section introduces some concepts that are central to understanding and configuring a network of DSAB-capable Dynon products. It then takes you through a series of simple steps to configure your network, enabling data sharing and HS34 functionality. Do not proceed with DSAB configuration until you perform all installation, calibration, and configuration steps for each instrument with a display. Display-less instruments – such as the HS34 – cannot be fully configured until DSAB is active, although their physical and electrical installation should be complete.

Network Concepts

A few concepts must be understood before configuring a DSAB-connected system. The most important is that of Dynon products as **providers** of functions to the network. These various functions are called **roles**. Some products, such as the HS34, only have one role on the network; other products can provide multiple roles at a time. When a device has been assigned to provide a role to the network, no other device on the network can provide that role at the same time.

Assignable roles by product	EFIS-D10A/ EFIS-D100	EMS-D10/ EMS-D120	FlightDEK- D180	HS34	SV32/42/52	AP74
Bus Master	X		X			
EFIS	X		X			
EMS		X	X			
OAT	X	X	X			
Compass	X		X			
HS34				X		
Autopilot	X		X			
AP Control Panel						X
AP Roll/Pitch Servo					X	

The table at right lists all available roles and the products which they can be assigned to. Again, each role can be assigned to no more than one device on the network.

Another important concept is that of the **Bus Master**. A DSAB-connected network must have at least one EFIS-based product (EFIS-D10A, EFIS-D100, or FlightDEK-D180), and only an EFIS-based product can be assigned the Bus Master role. The Bus Master is the instrument which manages communication on the network. Additionally, if Autopilot servos are installed, the Bus Master is the Autopilot. While the Autopilot can be controlled from slave devices, if the Bus Master is not present, the Autopilot will not function. If the Bus Master is turned off or fails, all data sharing ceases, causing units to display internally-derived data only. When you first perform DSAB network configuration on an EFIS-based instrument, that device is automatically assigned the Bus Master role. Perform DSAB configuration on your primary EFIS-based instrument, as the Bus Master is also the default provider for both the EFIS and Compass roles.



Example Networks

The following two diagrams present example DSAB-connected networks. These examples illustrate and expand upon some of the concepts discussed above. The first diagram depicts a system without an HS34 connected, demonstrating where NAV and GPS devices should be connected. The second diagram depicts a system with an HS34 connected, demonstrating that all NAV and GPS devices must be connected to the HS34. Both diagrams discuss what devices can be assigned various roles and what happens when DSAB fails.

Example System without HS34

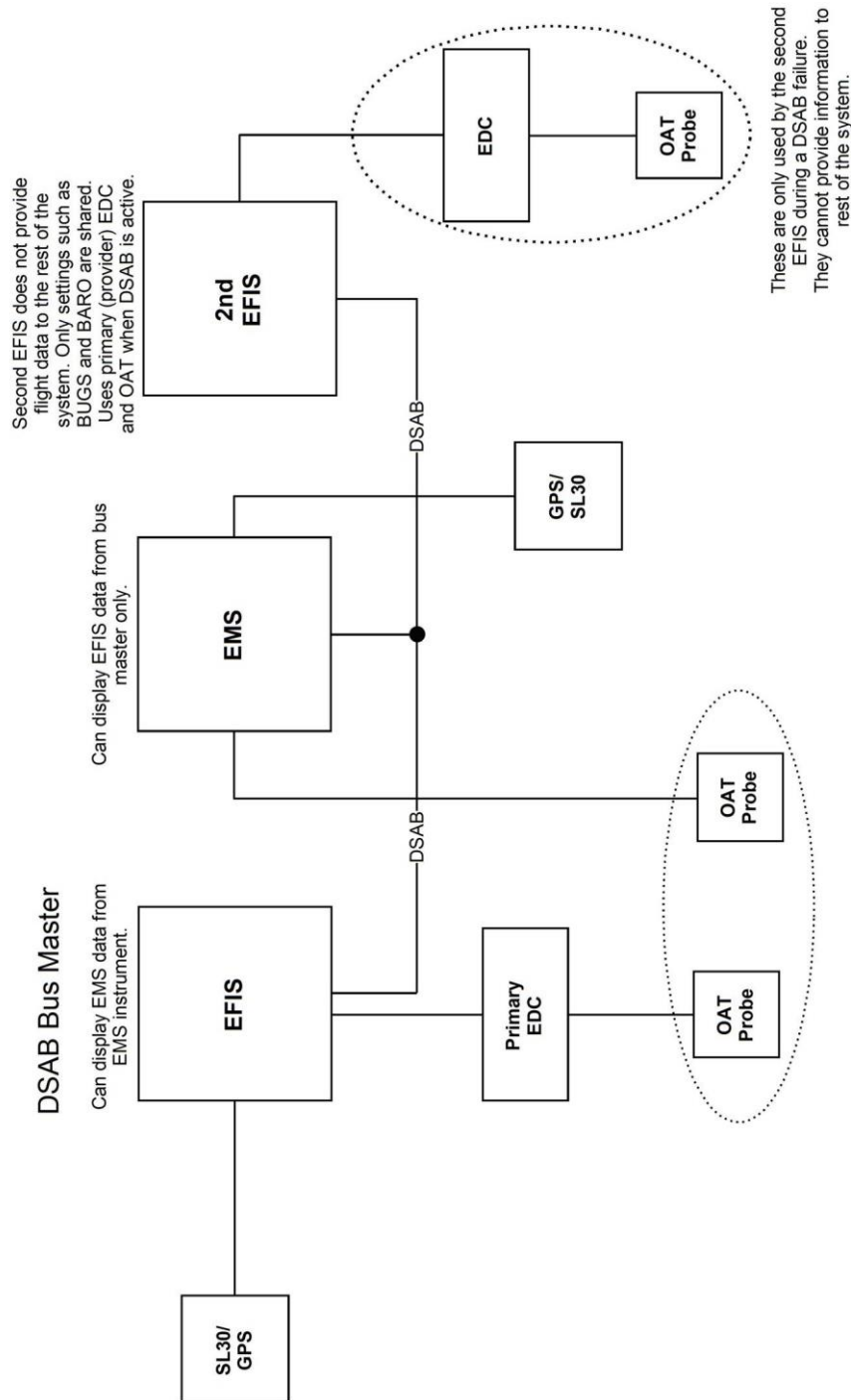

Either probe can be selected to fill the OAT role on the network.



Example System with HS34

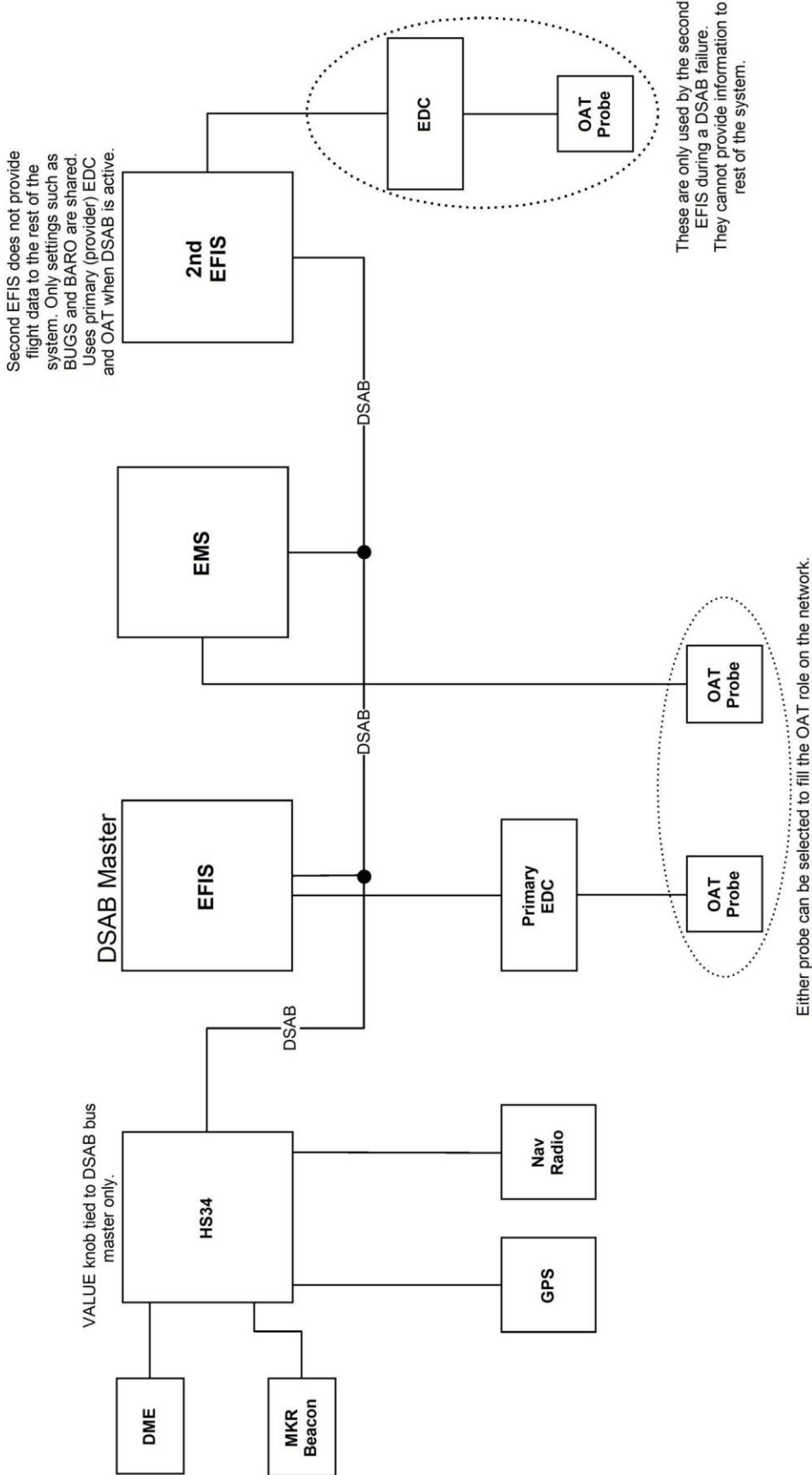



Initial Setup

As mentioned at the beginning of this chapter, configure your DSAB network only after all other installation steps have been performed, *including updating all products to the latest version of firmware available from the Dynon Avionics web site at downloads.dynonavionics.com*. To begin configuration, enter the EFIS > SETUP > DSAB menu. A full-page menu appears with three options: STATUS, CONFIGURATION, and BRIGHTNESS. Push DOWN ▼ to select CONFIGURATION and then SEL ► to enter the CONFIGURATION submenu. Note that if you press CONFIGURATION from an EMS-only product (via EMS > SETUP > DSAB), the display prompts you to begin the configuration process from an EFIS-based product.

If this is not your first time configuring your DSAB network, a prompt appears asking if you wish to re-configure the network. If you do not want to re-configure, press NO; otherwise, press YES to proceed with configuration as if this is a first-time install.

The first screen in the configuration process asks you to power on all devices in the system before pressing CONFIGURE NOW (button 1 or 2). After doing this, a second screen appears asking you to wait while the instrument detects all other devices connected via DSAB. While doing this, it assigns both the Bus Master and EFIS roles to itself.

During network detection, the Bus Master attempts to automatically assign as many roles as it can. The following table describes the logic used in assigning roles for network devices.

	How role is assigned
Bus Master	<ul style="list-style-type: none"> • Auto-assigned to instrument user is configuring on.
EFIS	<ul style="list-style-type: none"> • Auto-assigned to instrument user is configuring on.
EMS	<ul style="list-style-type: none"> • If one EMS detected, assigned automatically. • If Bus Master is EMS (i.e., FlightDEK-D180) assigned automatically. • If more than one non-bus-master EMS detected, user must assign.
OAT	<ul style="list-style-type: none"> • If one OAT detected, assigned automatically. • If more than one OAT detected, user must assign. • Note that for an OAT to be used it must be connected to an instrument assigned the EFIS or EMS role (i.e., if configuring DSAB on a FlightDEK-D180 with no OAT attached, the OAT role cannot be assigned to another instrument in the system as the FlightDEK-D180 is already assigned both the EFIS and EMS roles).
Compass	<ul style="list-style-type: none"> • Auto-assigned to instrument providing the EFIS/Bus Master roles.
AP CTRL PANEL	<ul style="list-style-type: none"> • If one AP74 detected, assigned automatically. • If more than one AP74 detected, error displayed: Not a supported configuration.
HS34	<ul style="list-style-type: none"> • If one HS34 detected, assigned automatically. • If more than one HS34 detected, error displayed: Not a supported configuration.

AP ROLL/PITCH SERVO	<ul style="list-style-type: none">• Roll Servo and Pitch Servo functions are automatically detected and assigned during Autopilot Servo Calibration process. See: EFIS > SETUP > AP > SERVO CALIB.• More than two SV32s or SV42s is not a supported configuration.
------------------------------------	--

If the configuration process could not automatically assign the EMS and OAT roles (because there are 2 or more of either type found on the network), it prompts you to assign each of them to the instrument of your choice. It then presents a list of all instruments on the network capable of being assigned each role. Use the DOWN ▼ and UP ▲ buttons to select the preferred instrument to provide the given role. The serial number for each unit is displayed next to its product type. Additionally, with an instrument type selected, pressing IDENT changes that instrument's display to a black screen with the text DSAB IDENT shown. If the instrument you wish to identify is the one which you are currently interacting with, the line changes to read THIS UNIT. When you have selected the preferred provider for the role, press SELECT to continue in the process. If necessary, repeat with the next manually assigned role.

At this point, a screen is displayed, stating:

```
(X) DEVICES FOUND  
NETWORK CONFIGURATION IS COMPLETE
```

Press FINISH to end the configuration. Press UP ▲ and SEL ► to view the status of all connected DSAB devices. Press UP ▲ or DOWN ▼ to scroll through all the devices. Cross-check the displayed devices against what you actually have installed and connected. Ensure that the STATUS for each device is listed as ACTIVE.

You may repeat the configuration process as many times as you wish. Whenever you add or remove an instrument from your network, you must redo the DSAB configuration process.

! Note that the following DSAB configurations are not supported:

- More than 1 FlightDEK-D180 in the network
- More than 1 HS34 in the network
- More than 1 AP74 in the network
- More than 2 servos in the network

Brightness Configuration

In a DSAB network, changing the brightness level of one instrument affects all connected instruments. Dynon Avionics sells D100-series instruments with both regular and bright screens. Each instrument connected to your DSAB network must have its display type configured to ensure that perceived brightness matches across all screens. To do this, enter the SETUP > DSAB > BRIGHTNESS menu on each product in the system. If you purchased the bright screen option for your EFIS-D100, press TOGGLE to change the BRIGHT SCREEN status to YES. Otherwise, ensure this is set to NO.

! If the DIM setting of one of the screens in a DSAB network gets “out of sync” (some dim, some bright), this can be corrected by adjusting the DSAB Bus Master screen to the desired DIM and then performing a DSAB CONFIGURE.

Network Status

The STATUS submenu displays information on all configured devices, their serial numbers, their roles on the network, and their status.

The first line indicates how many devices are configured on the network. This number is independent of the number of devices actually currently turned on and communicating. It simply reports how many instruments were present during the most recent execution of DSAB configuration.

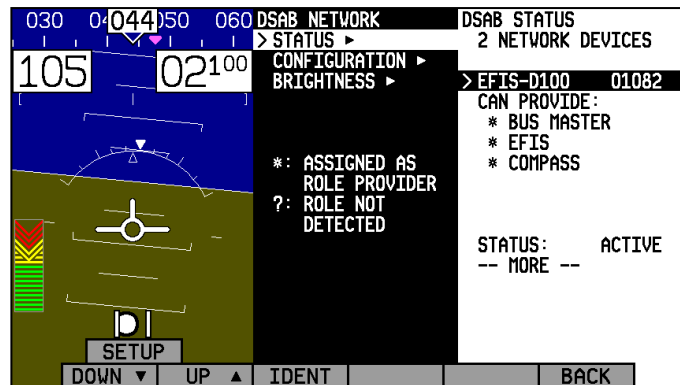

The next several lines indicate the available roles that the selected instrument can provide. A “*” is placed next to the roles that the instrument is currently providing to the network. If any of those roles cannot be detected (e.g., the EFIS’s compass has been disconnected), a “?” is displayed next to that role. Any given instrument in the list can have one of the following STATUS messages:

- **ACTIVE** – The device is communicating normally on DSAB.
- **STANDALONE** – During configuration as Bus Master, no other DSAB devices were found.
- **UPGRADE REQ** – Device has a different firmware version than the Bus Master and thus cannot communicate on DSAB.
- **OFFLINE** – The specified device cannot communicate on DSAB or is powered off.
- **PEERS LOST** – (Only appears on Bus Master) – The Bus Master was configured with other DSAB devices present; however, all of them are currently offline.

If an instrument’s STATUS field displays UPGRADE REQ, PEERS LOST, or OFFLINE, all of its provided roles are listed as not detected.

The selected instrument’s serial number is displayed, assisting in identification. Additionally, pressing IDENT causes the selected instrument’s display to display a black screen with the text DSAB IDENT shown. If the instrument you wish to identify is the one which you are currently interacting with, the line changes to read THIS UNIT.

Press DOWN ▼ or UP ▲ to scroll through each of the other instruments configured in your network.

6. AUTOPILOT INSTALLATION AND CONFIGURATION

Dynon Avionics' Autopilot (AP) system is a competitively priced product for the Experimental & Light Sport Aircraft (LSA) aircraft market. Unlike standalone AP systems, Dynon's AP is an enhancement to the Dynon Avionics EFIS-D10A, EFIS-D100, and FlightDEK-D180 products (beginning with firmware version 5.0). The Dynon Avionics AP provides roll (aileron) and/or pitch (elevator) control, leveraging the proven sensors, algorithms, and display systems of Dynon's modern EFIS products. Another innovative element of the Dynon Avionics AP is that the servomotors (servos) responsible for actuating the control surfaces are "smart" devices. Dynon's servos not only accept commands from the AP but also report "health," resistance to commanded movements, motor override (or "slip"), and many other data elements back to the EFIS. This level of communication between AP control and motors provides the pilot with an unprecedented degree of awareness of the overall performance of the AP. Dynon currently offers the following servo models:

Model Number	Torque	Attachment
SV32	36 inch-pounds	Standard Arm
SV32L		Long Arm
SV32C		Capstan
SV42	55 inch-pounds	Standard Arm
SV42L*		Long Arm
SV42C		Capstan

* SV42L servo is a special order item – contact Dynon Technical Support for details.

Dynon also offers the AP74 Autopilot Interface Module, which provides dedicated AP control via panel-mounted buttons and a knob. Dynon offers mounting kits for specific airframes, which include parts and detailed instructions. Additionally, Dynon Avionics supplies a generic mounting kit of basic parts that provides a head start for owners of aircraft not currently supported by our specific kits.

Additional Information and Updates

This guide provides generic mechanical installation guidelines to assist installers while integrating the Autopilot system into many aircraft. If you purchased a plane-specific kit from Dynon Avionics, it contains more detailed drawings and diagrams unique to your aircraft. You can find the list of Dynon's aircraft mounting kits on the current **Price List / Order Form** on Dynon's secure web site at store.dynonavionics.com. The drawings and installation instructions of current Dynon Avionics aircraft mounting kits are available on the Dynon web site at docs.dynonavionics.com.

Because the Dynon Avionics Autopilot is a new product and we expect that it will be installed in a wide variety of aircraft, Dynon's Internet sites provide up-to-date information on installation and operation issues:

wiki.dynonavionics.com – Dynon's Documentation Wiki provides enhanced, extended, continuously-updated online documentation contributed by Dynon employees and customers.



forum.dynonavionics.com – Dynon’s Online Customer Forum is a resource for Dynon Avionics customers to discuss installation and operational issues relating to Dynon Avionics products. The Forum is especially useful for pilots with uncommon aircraft or unusual installation issues. For customers that cannot call Dynon Technical Support during our normal business hours, the Forum is a convenient way to interact with Dynon Avionics Technical Support. The Forum allows online sharing of wiring diagrams, photos, and other types of electronic files.

Dynon will continue to develop kits and installation instructions for more aircraft based on demand. It is also expected that aircraft manufacturers will develop their own mounting kits for Dynon servos or offer the Dynon AP as a factory option. If Dynon does not currently offer a mounting kit for your particular aircraft, and you would be inclined to assist in developing a kit and documentation, please send an introductory email message about your interest to:

betatest@dynonavionics.com.

DSAB Firmware Compatibility



All Dynon instruments connected via DSAB must be running the same firmware version (currently version 5.4). This applies to the servos and AP74 as well. Because the servos and AP74 are updated via the DSAB Bus Master EFIS (the EFIS that you wish to control the AP, and from which you run the CONFIGURE DSAB command), wait until complete mechanical and electrical installation before performing the software upgrade steps. See Firmware Upgrades Required For AP Functionality on page 6-13 for more information.

Compass Calibration Critical For Certain AP Modes



The Dynon Avionics AP requires an accurate magnetic heading to operate efficiently and comfortably in HDG mode and the radio-based VOR/NAV mode. Therefore it is critical that the aircraft’s compass be installed correctly, calibrated, and operating well *in all attitudes*. If you currently have an EFIS-D10A, and are only using the internal magnetic compass, Dynon strongly recommends the installation and use of the EDC-D10A remote-mounted digital magnetic compass, and properly calibrating it per the instructions found in Chapter 4: Instrument Installation.

If the Dynon Avionics AP will be used exclusively in GPS NAV or TRK modes, then absolute accuracy of compass data is somewhat less critical as part of AP operation. But if NAV/GPS data is lost due to an equipment failure, bad data, loss of signal, etc. the AP will “fail over” to HDG mode, which uses the magnetic compass data as its source.



Autopilot System Electrical Installation

The diagram below provides an overview of the autopilot electrical system. The following sections describe the electrical installation of each subsystem in detail.

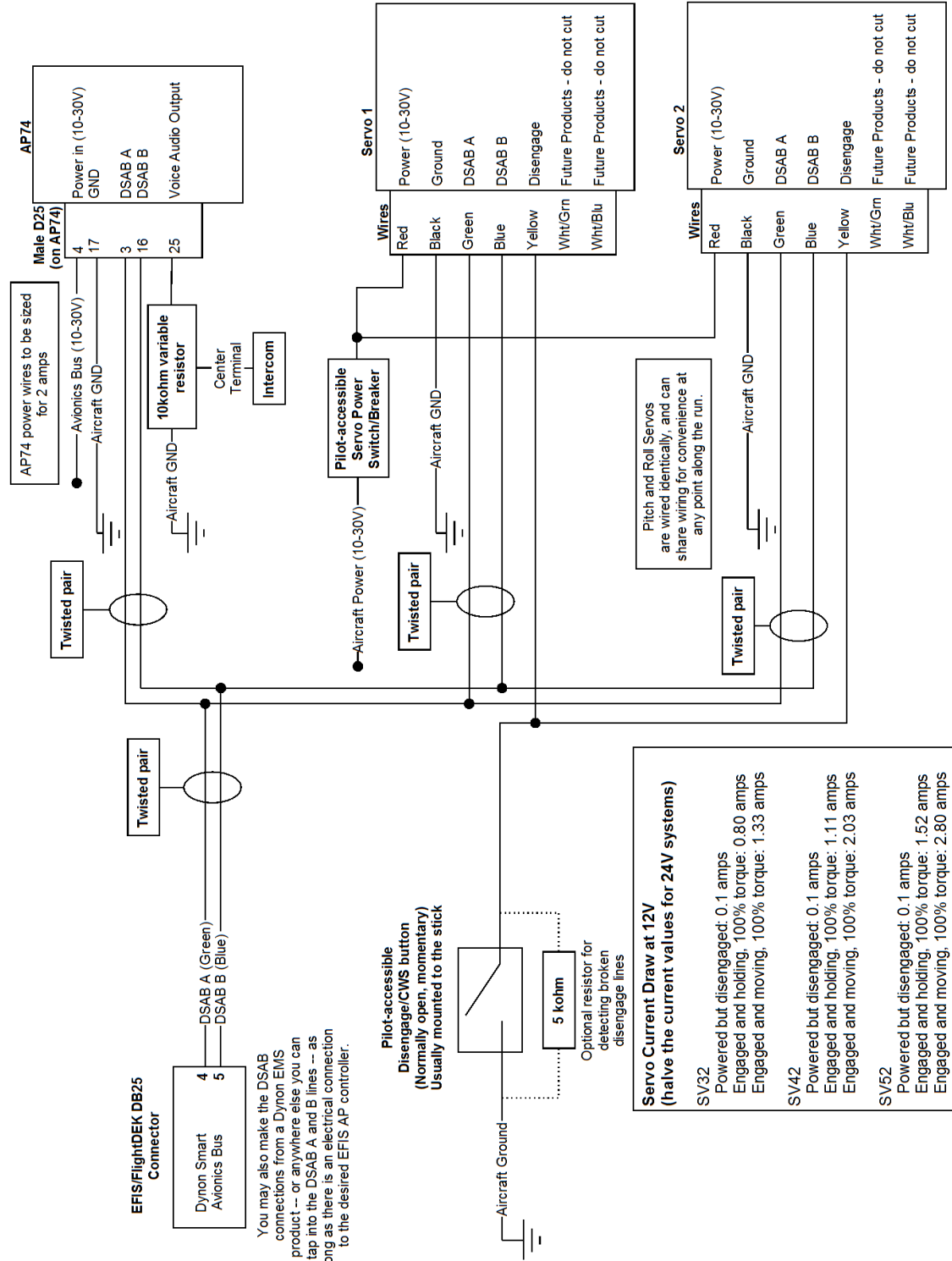



SERVO ELECTRICAL INSTALLATION

Dynon Avionics' servos are supplied with 7 un-terminated wires, each about 8" in length. It is the responsibility of the installer to decide on connectors and associated wiring. The 7 wires have the following colors and functions:

Color	Function	Notes
Red	Power	10-30 volts DC. Each servo draws up to 2 amps
Black	Aircraft Ground	Each servo draws up to 2 amps
Green	Dynon Smart Avionics Bus [DSAB] "A"	Connected in parallel with other DSAB devices (Green wire on all Dynon-supplied wiring harnesses)
Blue	Dynon Smart Avionics Bus [DSAB] "B"	Connected in parallel with other DSAB devices (Blue wire on all Dynon-supplied wiring harnesses)
Yellow	AP Disengage/Control Wheel Steering (CWS) Button	Connected through a normally-open pushbutton switch to Ground (disengages AP when button is pushed). If two servos are installed, the yellow wire from each servo is connected in parallel to a single pushbutton.
White/Green	Reserved for compatibility with Dynon "Next Generation" products	DO NOT CUT! During servo installation, Dynon recommends that this be routed to the cockpit panel (include sufficient slack behind the panel) <i>if</i> you want to preserve compatibility of the servo with Dynon's "Next Generation" technology. This wire is not used with the EFIS-D100.
White/Blue	Reserved for compatibility with Dynon "Next Generation" products	DO NOT CUT! During servo installation, Dynon recommends that this be routed to the cockpit panel (include sufficient slack behind the panel) <i>if</i> you want to preserve compatibility of the servo with Dynon's "Next Generation" technology. This wire is not used with the EFIS-D100.

- **Circuit Breaker/Switch:** We recommend that electrical power for the all servos be protected with an appropriately sized circuit breaker or switch that is accessible to the pilot while in flight.
- **Wire Sizing:** While it is beyond the scope of this installation guide to advise on specific types of wiring for a particular aircraft, choice of wiring should be sized to 1) minimize voltage drop over the length of the particular wiring run, and 2) conduct the amount of current required by the subsystem without the wiring becoming warm to the touch.
- **Wiring Installation:** Care should be taken such that aircraft wiring is not subjected to chafing, excessive flexing, or connections / junctions subjected to excessive vibration which may cause the connection/junction to fail or short-circuit. If the White/Green and White/Blue wires are extended to the cockpit panel, leave sufficient slack behind the panel for connection anywhere behind the panel. If the White/Green and White/Blue wires are not extended to the cockpit panel, as with other unused wires, DO NOT CUT the wires, but rather insulate the ends of the wires (electrical tape, heatshrink tubing), bundle, and secure the unused wire.

AP CONTROLS ELECTRICAL INSTALLATION

Circuit Breaker/Switch Install a circuit breaker or switch in a location that is accessible to the pilot while in flight.

AP Disengage/Control Wheel Steering Button

The AP Disengage/CWS button should be in a very accessible location, usually mounted to the stick or yoke. This button's primary purpose is to immediately disengage the autopilot. When configured in the EFIS > SETUP > AP > BUTTON CONFIG menu, this button can also be used to engage the Autopilot from an "off" status by holding the button for more than 2 seconds.

This button should be a Single Pole, Normally Open, Momentary button. Verify that two terminals of the button are shorted when the button is pressed and open (no-connect) when the button is released. One terminal of the button should connect to both servos' yellow wires, and the other should connect to ground.

While not required, you may install a 5 k Ω resistor across the AP Disengage/CWS button. When configured in the EFIS > SETUP > AP > BUTTON CONFIG > RESISTOR INST menu, the EFIS monitors the disengage line and displays a warning when a broken connection is detected.

AP74 ELECTRICAL INSTALLATION

- ⓘ When installing the AP74, we recommend building enough slack wiring into the D25 connector to allow the AP74 to be removed from its tray with the connector attached.

Use the D-sub pins/connector kit included with your AP74 to make the following connections:

- Pin 3: Dynon Smart Avionics Bus (DSAB) "A", connected in parallel with all other DSAB B connections (Green wire on Dynon-supplied wiring harnesses)
- Pin 4: Power, 10 - 30 volts DC
- Pin 16: Dynon Smart Avionics Bus (DSAB) "B", connected in parallel with all other DSAB A connections (Blue wire on Dynon-supplied wiring harnesses)
- Pin 17: Aircraft Ground
- Pin 25: Outer terminal of AP Audio Adjustment Potentiometer (detailed below); If HS34 installed and providing audio to your intercom system, do not connect the AP74 audio out. If both the HS34 and AP74 Voice/Tone outputs are connected to your intercom, audio alerts will be distorted.

Ensure that the AP74 audio output is connected similar to the following diagram. The 10 k Ω variable resistor can be obtained from Radio Shack (P/N 271-1715) or other electronics suppliers. The potentiometer does not need to be pilot-accessible as it is typically adjusted only during setup and configuration. See Step 6 - Audio Alerts Configuration on page 6-23.

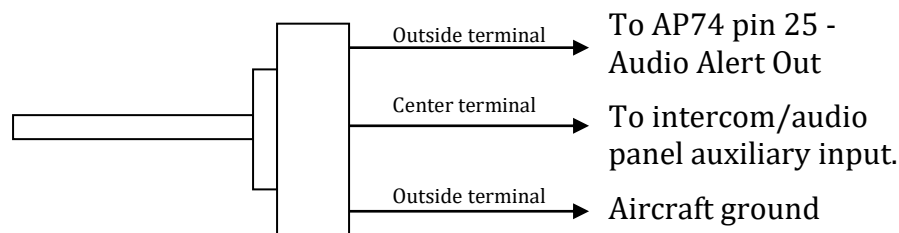

Note: As with the optional Dynon HS34, it is acceptable to connect the tone output of EFIS (DB25 Pin 18) and/or EMS (DB37 Pin 31) in parallel with the tone/voice output of the AP74 (Pin 25) to provide “failover” audio alerts from the EFIS and/or EMS if the AP74 were to fail. However, do not connect the audio outputs from an HS34 and AP74 in parallel.

Servo Mechanical Installation

Dynon Avionics has researched suitable mounting points for a number of popular aircraft and offers mounting kits and instructions for them. If you have purchased one of these kits, use the instructions included with it as your primary guide; the following mechanical installation information is more general in nature.

For installing Dynon Avionics servos in aircraft for which Dynon does not offer kits, we offer a “generic” kit of basic parts and basic installation instructions: Dynon P/N 101020-000. The generic servo push-pull mounting kit includes some of the hardware to mount a servo and connect to the aircraft controls, but requires the installer to fabricate mounting brackets. This kit can be used in either pitch or roll applications that use a servo with an output arm (not suitable for use with pulley/cable servos). Some additional fasteners (not supplied by Dynon) and brackets will be required depending on the installation method chosen.

- ❗ **CAUTION:** Neglecting to properly install and/or use Dynon Avionics AP hardware can result in failures which could cause loss of aircraft control resulting in aircraft damage, personal injury, or death. If there are any questions on the part of the installer it is mandatory to resolve these questions prior to flight.

When installing the servo, you must first determine a mount location for proper interaction with the existing control system. The mounting point that is chosen must allow the servo arm and associated linkage to move freely through the entire range of travel. To prevent the possibility of the servo arm going **OVER CENTER**, the servo arm must not travel more than a total of $\pm 60^\circ$ from neutral position. When the aircraft controls are centered, the arm of the servo should be perpendicular to the attaching push rod. If this is not the case, we recommend adjusting the length of the push rod or consider a different mounting point. For maximum efficiency and the lightest drag on the flight controls, you should choose the smallest servo that provides sufficient torque to move and hold the flight controls with a minimum of “slippage”. A diagram of servo torque versus mount position is shown on page 6-9.

- ❗ **CAUTION:** The servo arm must not rotate *even near* to the point called **OVER CENTER**, the point at which the primary aircraft control would “lock up”. Over center happens when the angle between the servo arm and the attached push rod becomes so great that the control system cannot drive against the servo arm. To protect against this possibility, a Range of Motion Limiting Bracket is supplied with each Dynon Avionics servo. These brackets are drilled so that they can be mounted at different angles as required (18° intervals). The brackets are supplied for the protection of the pilot, and we recommend that the Range of Motion Limiting Bracket be installed to ensure that an **OVER CENTER** condition *cannot* occur.

Once a suitable mounting point for each servo has been determined, the next step is to fabricate a mount for the servo to attach to the aircraft. Generally this will be a bracket made of sheet metal or corner stock. Dynon recommends using 6061 T6 aluminum with a minimum thickness of



0.050” for the best balance of strength to weight. When fabricating a mounting bracket, refer to the servo dimensions below. Be sure to leave ample room for the arm and attached linkage to move through a *complete range of motion* without interference.

- ❗ **CAUTION:** In normal operation, Dynon’s servos can reach temperatures that can be very uncomfortable to, and perhaps cause burns to unprotected skin. Thus, servos should be mounted in an area, or in such a manner to prevent accidental skin contact. If mounting the servo in an exposed area *is* necessary, a shroud should be installed (that doesn’t restrict ventilation) that protects against accidental skin contact with the servos.



SERVO DIMENSIONS

Use the following dimensions (in inches) for reference when planning and implementing your installation.

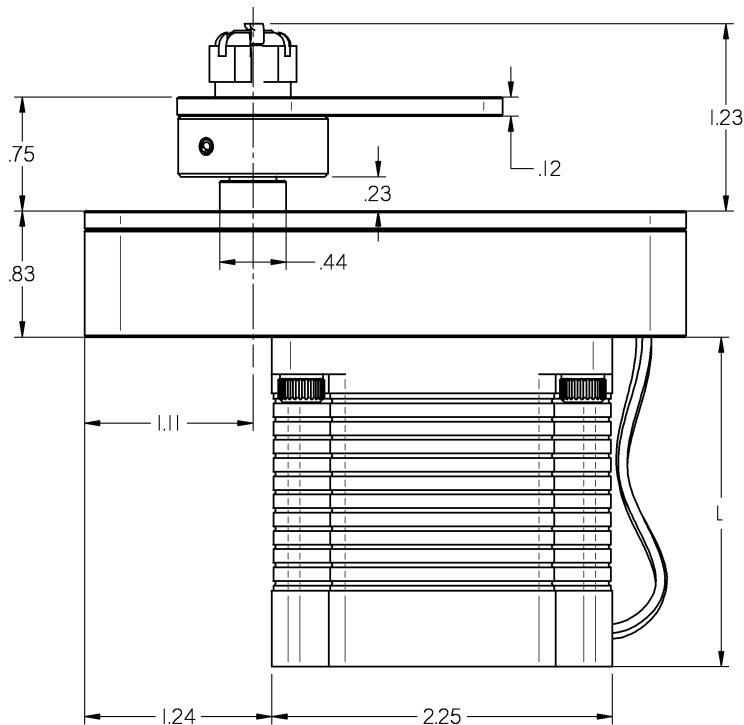
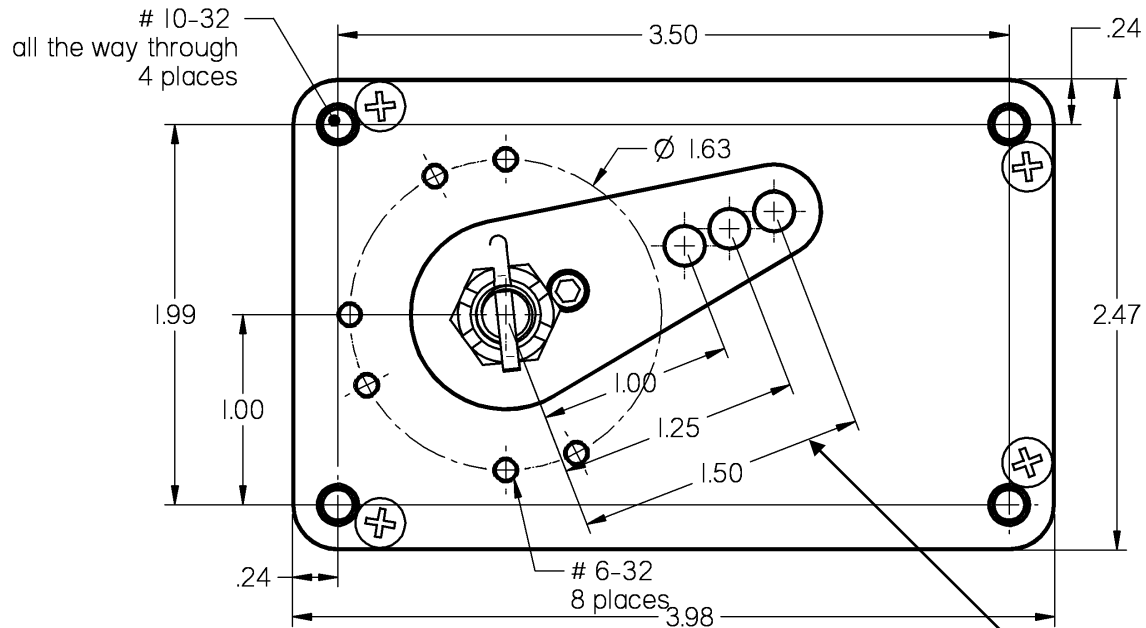

Long-arm variants (not needed in most installations) have linkage mount holes at 1.5", 1.75", and 2.0"

	L	Weight
SV32	2.17"	2 lb
SV42	3.10"	3 lb
SV52	4.02"	4 lb

LINKAGE MOUNT POSITION FORCE AND TRAVEL

The two diagrams below illustrate the maximum travel and force available at each linkage mounting point. As can be seen, the closer you mount the linkage to the shaft, the more force the servo can deliver. However, this also means the travel of the arm is shorter. Again, ensure that the servo arm is nowhere near going over-center throughout the entire range of the control system.

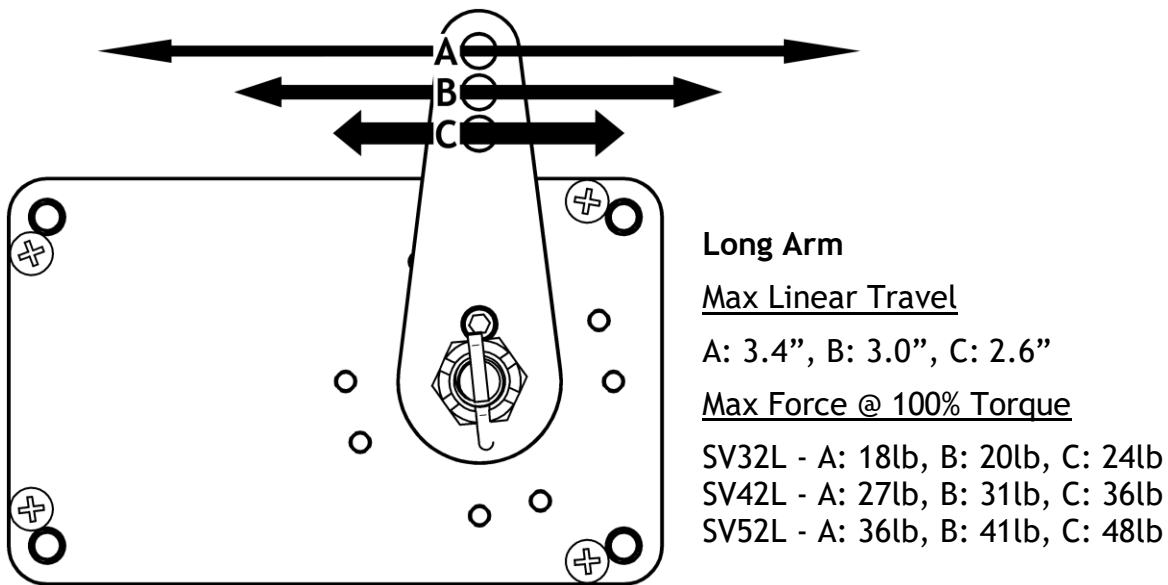
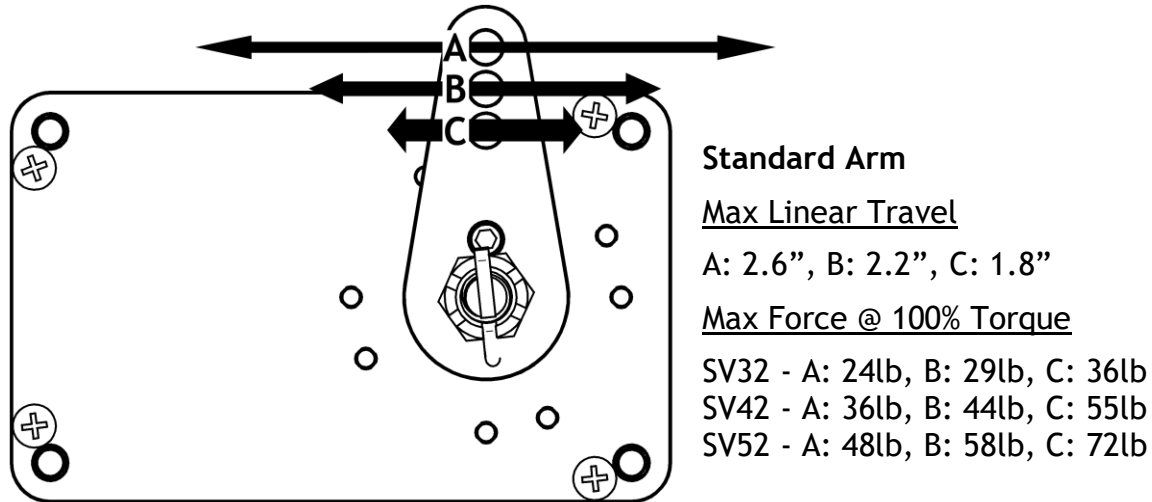

In most instances, it is recommended to connect the servo arm to the control linkages using the outer-most hole of the servo arm (position A). This position provides the greatest amount of travel, with the least amount of drive force. If, when testing the autopilot, you find that the servos cannot adequately drive the control system (indicated by a yellow "slip indicator" in the AP status at the bottom left of the EFIS screen), you may move the linkage mount point inward, provided there is still enough travel to accommodate the control system at the servo location. Using either of the two inner-most holes of the servo arm affects the final amount of force that



the servo can exert, arm travel, control surface resolution, and the amount of force required to shear the brass shear screw. The two inner-most holes of the servo arm should only be used if the installer *fully understands the resulting implications*. The diagrams above illustrate the linear travel and available force for each mount point on the standard and long-arm servos.

! **CAUTION:** Each Dynon Avionics servo includes a precision-machined brass “shear screw” that pins the servo arm to the servo arm attachment, providing an ultimate “manual override”. The shear screw will break at the application of 100 inch-pounds of torque, at which point the servo arm will travel freely. If the brass shear screw is broken during AP installation or usage, do not replace it with a standard screw - contact Dynon for a replacement shear screw.

There will be a variety of methods used to install the other end of this control linkage to the existing mechanicals of the aircraft. Some systems will use a hole drilled into the bell crank as the point where the servo push rod/rod end combination interfaces with the controls. Others will use an attachment to existing linkage. Others may attach directly to the control stick itself. It is up to the installer to decide which method is best in terms of safety and AP functionality.

Installers should always keep in mind the range of motion of the servo. Total servo arm travel needs to be limited to prevent an OVER CENTER condition (see caution note above), while still preserving the control surfaces’ full range of motion. Carefully consider the prevention of an over center condition when selecting the mounting location and linkage attachment point for any servo installation. The built-in control stops of the aircraft will limit the servo arm travel when installed correctly. Again, Dynon strongly recommends that the included Range of Motion Limiting Bracket be installed in order to absolutely prevent the possibility of an over center condition. The Range of Motion Limiting Bracket should not be used as a normal stop; the aircraft’s built-in stops should always be the primary range limit.



AP74 Mechanical Installation

This section provides you with dimensions, panel location, and mounting information for the AP74 Dedicated Autopilot Interface.

AP74 DIMENSIONS AND PANEL LOCATION

The diagram below shows the AP74's outer dimensions. Note that the instrument extends about 3.7" behind the panel, and that a harness can require up to three more inches. Use the dimensions (in inches) found on the diagram to plan for the space required by the instrument. The front bezels of the vertically oriented AP74 (100756-000) and are the same height as Dynon's D100-series products and can be mounted close to – or abutted against – one if desired. Plan a panel location that allows for convenient operation of the knobs and buttons. If you plan on using the auto-dim feature, ensure that the instrument is in a location where the light sensor (small circle of rubber on the front of the instrument) can measure the true ambient light conditions in the cabin.

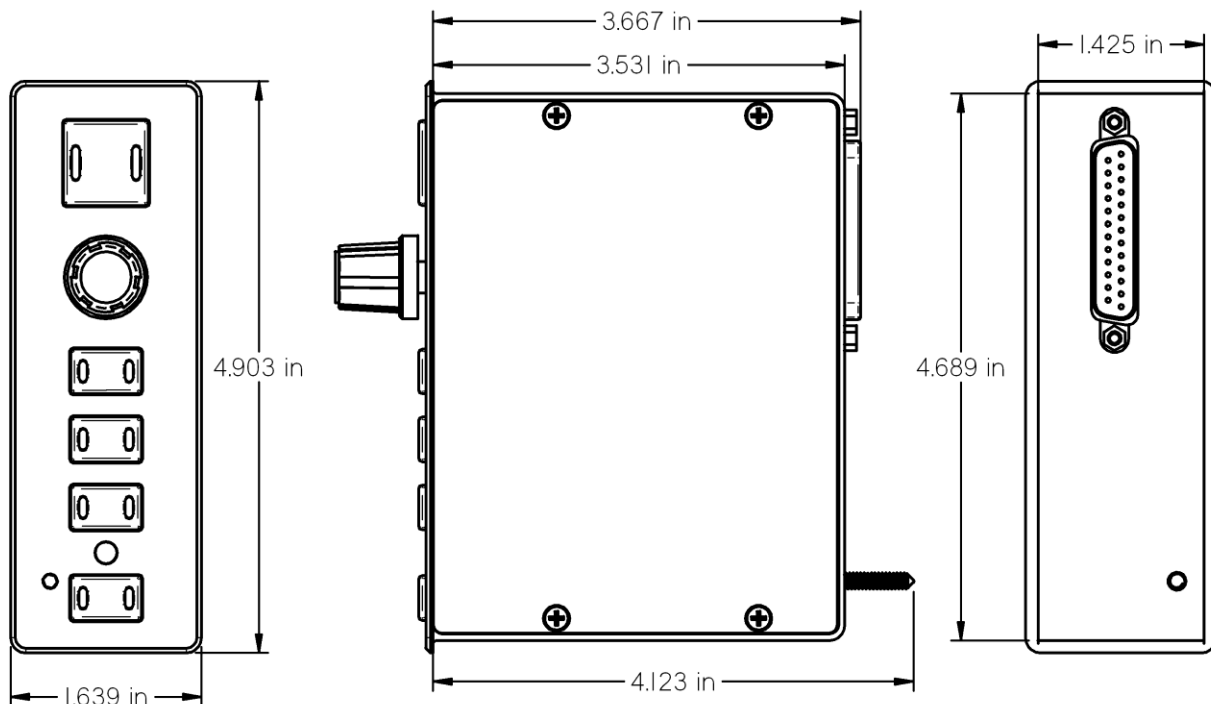

MOUNTING BRACKET DIMENSIONS

The dimensions for the included mounting bracket are below. This bracket will work with varying panel thicknesses in both vertical and horizontal orientations. The primary force used to secure the instrument to a panel is the “sandwich” action of tightening the bracket behind through to the instrument bezel in front. The bracket includes a small mounting flange that can be used to positively secure the bracket to the panel if desired. While not required for secure mounting (the mounting screw clamps the panel between the bezel and bracket), securing the bracket to the panel can make removal of the instrument easier by preventing the bracket from falling behind the panel when removed. If you wish to use the mounting flange, simply match drill it and rivet or bolt it in the desired spot. See the following section for details on where to locate the bracket with respect to the hole in the panel. This flange can be trimmed if it is not needed or if it interferes with other instruments.

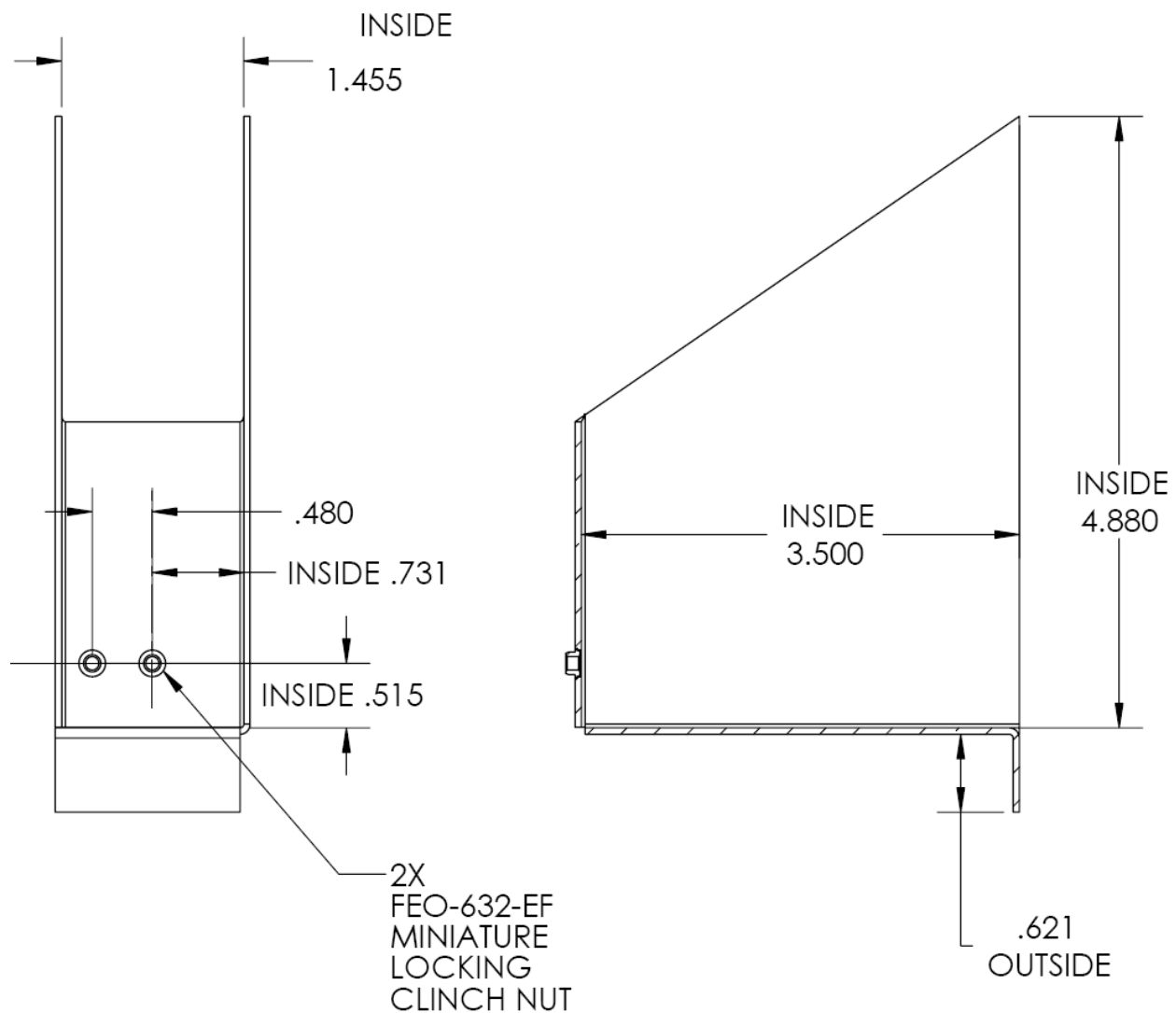

AP74 MOUNTING

As shown in diagram below, make a rectangular cutout (oriented either vertically or horizontally, depending on instrument version ordered) of 1.45” by 4.75” (3.69 cm by 12.07 cm). Your AP74 also shipped with a life-sized mounting template for making this cutout and locating the optional mounting flange holes. If the flange is used, secure it to your panel in whatever way you desire. Riveting it to the panel is ideal, but drilling holes for mounting screws and nuts also works.

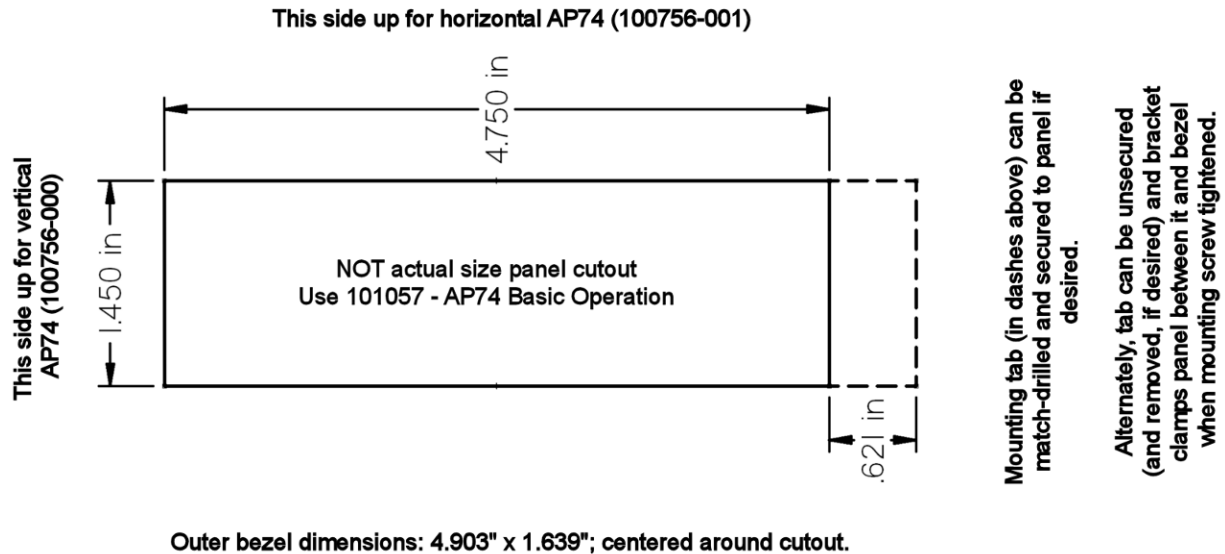

Upon locating the mounting bracket behind your panel, slide the instrument into it. The tapered mounting screw fits into one of the PEM nuts at the back of the mounting bracket. Use the included 7/64” Allen wrench to secure the mounting screw into the bracket. As you screw the mounting screw tighter, the unit will be pulled back into the panel until the bezel sits flush. If the bracket is installed without the assistance of the mounting flange, it will also be drawn forward into the back of the panel when tightened. Tighten until the flange and bracket are securely fastened to the panel.

Firmware Upgrades Required For AP Functionality

- ⚠ Because servo and AP74 firmware is upgraded at the same time as the Bus Master EFIS, servo and AP74 power must be ON when EFIS firmware is upgraded.

To use the Dynon Avionics AP, the EFIS *and all other Dynon products in the DSAB network* must be running the same firmware version (currently 5.4). This includes EFIS, EMS (including those configured as backup/slave units), HS34, AP74, servos, and the EDC-D10A compass. EFIS, EMS, and HS34 products must be individually upgraded via their individual serial ports connected to a PC and running the latest version of the Dynon Avionics Product Support Program. **Autopilot servos and the optional AP74 are upgraded as part of the upgrade of the DSAB Bus Master EFIS (as is the EDC-D10A).** To ensure reliable operation, all Dynon devices should be upgraded to the same version of firmware; mismatched versions of firmware on different devices can cause unreliable operation.



Detailed instructions for performing firmware upgrades are contained in the “Help” function of the Dynon Avionics Product Support Program which is available on the Dynon Avionics web site at downloads.dynonavionics.com.

- ❗ If you are using a GPS connected to your Dynon EFIS and will be using GPS as an input for the AP, please upgrade your GPS to the most current firmware available for it. Dynon’s testing has revealed certain incompatibilities with older versions of GPS firmware that are corrected with current GPS firmware. Procedures for GPS firmware upgrades vary by manufacturer; consult your GPS manual for the firmware upgrade procedure. Additionally, some GPS units must be configured with specific settings to work properly with Dynon’s instruments. More detail on compatibility with, and settings for various GPS units is available on the Dynon Avionics web site at wiki.dynonavionics.com.

AP Servo Configuration

This section guides the installer through all the steps necessary to install, configure, and tune the Autopilot software on the EFIS/servo system. The AP operation functions dealt with here are primarily focused on configuration and tuning. Pilots should consult the EFIS-D100 Pilot’s User Guide for a comprehensive description of AP operation.

Note: Before proceeding, verify that power is **ON** for all EFIS, EMS, HS34, AP74 *and* servo(s).

Note: If your system has more than one Dynon EFIS (that communicates over DSAB), the configuration of most AP functions can only be performed from the EFIS configured as the DSAB Bus Master (see Network Concepts on page 5-1).

CONFIGURATION OVERVIEW

1. **Configure DSAB** (required to be performed on the ground)
2. **Servo Calibration & Initial Servo Test** (required to be performed on the ground)
3. **Roll Servo Initial Setup** (recommended to be performed on the ground)
4. **Pitch Servo Initial Setup** (recommended to be performed on the ground)
5. **Disengage/CWS Button Configuration** (recommended to be performed on the ground)
6. **Audio Alerts Configuration** (recommended to be performed on the ground)
7. **Prepare for Flight Test** (recommended to be performed on the ground)
8. **Roll Servo Flight Calibration** (recommended to be performed in flight *under safe conditions*)
9. **Pitch Servo Flight Calibration** (recommended to be performed in flight *under safe conditions*)

STEP 1 - CONFIGURE DSAB

This step sets up the DSAB network so that the EFIS can communicate with the servo(s), optional AP74, and any other Dynon products on the DSAB network.

- ❗ As a safety precaution, while the Configure DSAB procedure is being performed, AP functionality is disabled.

On the EFIS, perform the following:



- Enter the EFIS > SETUP > DSAB > CONFIGURATION menu.

ARE YOU SURE YOU WANT TO RE-CONFIGURE THE NETWORK?

- Press YES

ARE ALL NETWORKED DEVICES POWERED ON?

- Press CONFIGURE NOW

PLEASE WAIT DETECTING ALL NETWORK DEVICES

- Wait up to 1 minute

(X) DEVICES FOUND NETWORK CONFIGURATION IS COMPLETE

- Verify that this shows the correct number of devices. If not, check wiring and ensure that all expected devices are powered on.
- Press FINISH
- Press UP▲ > and then SEL▶ to select the STATUS menu. The Bus Master EFIS should be displayed, showing active roles and status. Verify that STATUS (at bottom) shows ACTIVE.
- Press DOWN▼ once for each device in the network. Verify that the STATUS for each device shows ACTIVE. **If the status displays UPGRADE REQ, that instrument must be updated to the same version of firmware as the Bus Master EFIS.** If the instrument displaying UPGRADE REQ is one or more of your servos and/or AP74 (most commonly when these devices were purchased separately from your EFIS), you must perform the upgrade via the Bus Master EFIS, even if the EFIS is already at version 5.4 firmware.
- After the above verification, press BACK > EXIT

STEP 2 - SERVO CALIBRATION AND SERVO TEST

The Servo Calibration procedure identifies the orientation and range of motion of each servo. The Servo Test procedure verifies that each servo is configured properly by moving the control surfaces, and requiring the pilot to verify correct movement. Until this procedure is completed, the EFIS does not display the AP status or operation interface.

- ❗ If Airspeed Color Thresholds have not been configured, Servo Calibration and Servo Test cannot proceed, and the EFIS displays an error message. To configure Airspeed Color Thresholds, see Configure Airspeed Color Thresholds on page 4-4.

Note: Servo calibration (SERVO CAL) and servo test (SERVO TEST) is a combined procedure; when Servo Calibration is completed successfully, you are prompted to perform Servo Test. After a successful servo calibration, the SERVO TEST procedure can be performed on its own whenever desired.

Note: The following steps assume that two servos are installed to provide AP control of Pitch and Roll functions. If only a Pitch or Roll servo has been installed, skip the non-applicable sections.

On the EFIS, perform the following:

- Enter the SETUP > AP > SERVO CALIB menu.



2 SERVO(S) FOUND PLEASE CENTER ALL CONTROL SURFACES AND MAKE SURE THEY HAVE A FREE RANGE OF MOTION. PRESS DISCONNECT SWITCH TO CONTINUE.

- Follow all onscreen instructions, moving the controls to each position, pressing the Disengage/CWS Button to confirm each position. This process calibrates the autopilot to detect the orientation and range of each servo.
- If calibration was successful:

CALIBRATION WAS SUCCESSFUL. ROLL FOUND. PITCH FOUND. PRESS OK BELOW OR PRESS DISCONNECT SWITCH TO CONTINUE.

- Press the AP Disengage/CWS Button or OK button on the EFIS.
- If calibration was unsuccessful, an error message is displayed, describing the reason. The most common causes are not enough travel being detected, or too much travel. In either case, mechanical adjustments must be made.

After successful completion of the calibration, the system automatically continues into SERVO TEST Mode. An initial SERVO TEST must be performed before the autopilot is usable. If the initial SERVO TEST is canceled, the AP status display at the lower left of the EFIS screen shows “TST” as the status for the installed servo(s).

- After successful calibration the screen displays:

PLEASE CENTER ALL CONTROL SURFACES AND MAKE SURE THEY HAVE A FREE RANGE OF MOTION. PRESS OK BELOW TO BEGIN THE TEST.

- Follow all onscreen instructions, moving the controls to each position, pressing the OK button to confirm each position. This process verifies that the controls move to the correct position, and ensures that the Disengage/CWS Button properly disengages the servos.

Note: After *successful* completion of Configure DSAB, Servo Calibration, and Servo Test, the AP mode is enabled. The following occurs:

- The AP status indicator is displayed at the lower left of the EFIS screen (shown at right).
- The AP button is present on the EFIS menu, replacing the BUGS menu (which is now located within the AP menu).
- All bugs (IAS, Heading, and Altitude) are turned hollow. With an autopilot installed, the heading and altitude bugs are only filled in when those modes are engaged (HDG, TRK, ALT hold).
- The EFIS now has a record of which servo performs which function and the particular range of motion it will be executing.



- ! If servos are swapped or replaced, Servo Calibration *must* be performed again.

STEP 3 - ROLL SERVO INITIAL SETUP

We recommend that you perform the following on the ground at zero airspeed.

Step 3a – Set Roll Servo Torque: The ROLL SERVO > TORQUE parameter specifies how much torque the servos will exert before slipping. Servo slip is indicated by a yellow background on the slipping axis in the AP status indicator. Torque must be set high enough to prevent any slip due to air loads, but low enough that the pilot can comfortably override the AP should the need arise. If the servo slips continuously, the AP cannot fly the aircraft. Torque is specified in % of maximum the servo is capable of exerting. Minimum: 10%, maximum 100%, default: 100%.

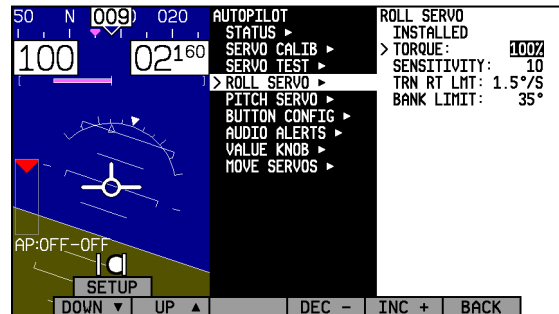

On the EFIS, perform the following:

- If not already in the SETUP > AP menu, enter the menu and select ROLL SERVO and press SEL▶
- (TORQUE value is highlighted)
- Press DEC - and INC + to adjust TORQUE to preferred *initial* setting for the aircraft.

It may take some experimentation to find the right value for your aircraft, but if you are comfortable overriding the servo with the default value of 100%, it is safe to leave that setting at the default value. To test servo override, exit the SETUP > AP menu and return to the main EFIS menu. Center the aircraft controls. Enter the EFIS > AP menu and press HDG OFF. Note that the mode toggles to HDG ON, the HDG bug synchronizes to the current heading, and the roll servo engages. Ensure that the controls do not deviate far from center.

AP74 If you have an AP74 installed and configured, you can accomplish this same procedure by doing the following: Push the HDG button to ensure that it is lit; push the ALT button until it is *not* lit. Push the AP button to engage the AP in Heading Hold mode.

Now, take the controls and override the servo by moving to either roll left or roll right (remember, you are only overriding the roll servo, so you should feel no resistance in the pitch axis). Ensure that you are comfortable with the amount of force it takes to override the servo. If you are not, decrease the roll servo TORQUE value by 10% and repeat the test.

Step 3b – Set Roll Servo Sensitivity: The ROLL SERVO > SENSITIVITY parameter specifies the how fast or slow the AP responds to deviations between commanded direction and actual heading or track. If Sensitivity is set too low, the aircraft will “wallow” during changes in heading. If Sensitivity is set too high, the aircraft will be “twitchy,” with frequent, fast, aggressive adjustments. Sensitivity is specified in digits. Minimum: 1 (low sensitivity), maximum: 25 (high sensitivity), default: 10.

This parameter can be tuned in flight; leaving it at the default of 10 is sufficient for initial setup. If the autopilot is not as “decisive” as you’d like, increase this value; if it is too aggressive, decrease it.

On the EFIS, perform the following (continuing from TORQUE):



- DOWN▼ > (SENSITIVITY value is highlighted)
- Press DEC - and INC + to adjust SENSITIVITY to preferred *initial* setting for the aircraft.

Step 3c – Set Roll Servo Turn Rate Limit: The ROLL SERVO > TRN RT LMT parameter specifies the desired average turn rate for AP-commanded turns. For example, a setting of 3.0°/S will ideally complete a 90° turn in 30 seconds. Due to flight dynamics and the time it takes the Autopilot to initiate a turn, there may be points during a turn where the target Turn Rate Limit is slightly exceeded. Turn Rate Limit is specified in °/s (average degrees of turn per second). Minimum: 0.5°/s, maximum: 3°/s, default: 1.5°/s.

On the EFIS, perform the following (continuing from SENSITIVITY):

- DOWN▼ > (TRN RT LMT value is highlighted)
- Press DEC - and INC + to adjust TRN RT LMT to preferred *initial* setting for the aircraft.



Firmware version 5.3 introduces an alternate set of control algorithms which may improve roll performance in some aircraft. To try this mode simply set TRN RT LMT to 0. The autopilot will more directly control bank angle instead of targeting a specific turn rate. The maximum bank angle that the autopilot allows continues is still limited by the BANK LIMIT parameter. In this mode, set the BANK ANGLE LIMIT to the maximum value you want the autopilot to use in a turn (see below).

Step 3d – Set Roll Servo Bank Limit: The BANK LIMIT parameter specifies a maximum bank angle which the AP will not exceed during turns. Setting an appropriate Bank Limit protects against overbank conditions. If the BANK LIMIT setting is reached during a turn, the AP limits the bank to that value and then reduces it as needed to complete the turn.

If BANK LIMIT is reached, the Turn Rate Limit (set previously) is ignored until the aircraft returns to within 5° of level in the roll axis.

To choose an appropriate BANK LIMIT, calculate the bank angle that results from your desired turn rate limit and cruising airspeed; then set the BANK LIMIT to at least 5° above this value. If this bank angle value is a number that you are not comfortable with, decrease the target TRN RT LMT (set above). Minimum: 05°; maximum; 45°, default: 35°.

On the EFIS, perform the following (continuing from TRN RT LMT):

- DOWN▼ >(BANK LIMIT value is highlighted)
- Press DEC - and INC + to adjust BANK LIMIT to preferred *initial* setting for the aircraft.
- BACK > EXIT

STEP 4 – PITCH SERVO INITIAL SETUP

We recommend that you perform the following on the ground at zero airspeed.

Step 4a – Set Pitch Servo Torque: The PITCH SERVO > TORQUE parameter specifies how much torque the pitch servo will exert before slipping. Servo slip is indicated by a yellow background on the slipping axis in the AP status indicator. Torque must be set high enough to prevent any slip due to air





loads, but low enough that the pilot can override the AP should the need arise. If the servo slips continuously, the AP cannot fly the aircraft. Torque is specified in % of maximum the servo is capable of exerting. Minimum: 10%, maximum 100%, default: 100%.

On the EFIS, perform the following:

- If not already in the SETUP > AP menu, enter the menu and select PITCH SERVO and press SEL▶
- (TORQUE value is highlighted)
- Press DEC - and INC + to adjust TORQUE to preferred *initial* setting for the aircraft.

It may take some experimentation to find the right value for your aircraft, but if you are comfortable overriding the default value of 100%, it is safe to leave that setting at the default value. To test servo override, exit the SETUP > AP menu and return to the main EFIS menu. Center the aircraft controls. Enter the EFIS > AP menu and press ALT **OFF**. Note that the mode toggles to ALT **ON**, the ALT bug synchronizes to the current altitude, and the pitch servo engages. Ensure that the controls do not deviate far from center.

AP74 If you have an AP74 installed and configured, you can accomplish this same procedure by doing the following: Push the ALT button to ensure that it is lit; push the HDG button until it is *not* lit. Push the AP button to engage the AP in Altitude Hold mode.

Now, take the controls and override the servo by moving to either pitch down or pitch up (remember, you are only overriding the pitch servo, so you should feel no resistance in the roll axis). Ensure that you are comfortable with the amount of force it takes to override the servo. If you are not, decrease the roll servo TORQUE value by 10% and repeat the test.

Step 4b – Set Pitch Servo Sensitivity: The PITCH SERVO > SENSITIVITY parameter specifies the how fast or slow the AP responds to deviations between commanded altitude and actual altitude. If Sensitivity is set too low, the aircraft will “wallow” during changes in altitude. If Sensitivity is set too high, the aircraft will be “twitchy,” with frequent, fast, aggressive adjustments. Sensitivity is specified in digits. Minimum: 1 (low sensitivity), maximum: 25 (high sensitivity), default: 10.

This parameter can be tuned in flight; leaving it at the default of 10 is sufficient for initial setup. If the autopilot is not as “decisive” as you’d like, increase this value; if it is too aggressive, decrease it.

On the EFIS, perform the following (continuing from TORQUE):

- DOWN▼ > (SENSITIVITY value is highlighted)
- Press DEC - and INC + to adjust SENSITIVITY to preferred *initial* setting for the aircraft.

Advanced Pitch Gain and Rate Adjustments

There are several additional advanced parameters that can be used to fine tune the performance of the pitch axis. They should be considered secondary to the primary Pitch Axis Sensitivity adjustment. When used, they should be adjusted in the following order:

- Pitch Gain: Use only after sensitivity is set as well as it can be. Increase gradually if airplane does not settle on altitude. The default setting is 20.



- **Altitude Gain (ALT GAIN):** Use only after sensitivity and all of the above settings are set as well as they can be. Increase gradually if airplane levels off too soon. Reduce gradually if airplane overshoots altitudes after climbs and descents. The default setting is 6.
- **Pull Rate:** Use only after sensitivity and all of the above settings are set as well as they can be. Controls the rate the AP will push or pull when changing vertical speed. The default setting is 10.
- **VSI Gain:** Use only after sensitivity and all of the above settings are set as well as they can be. Increase gradually if overshooting altitude after climbs or descents, decrease if rounding out too early. The default setting is 15.
- **G Error Gain (G ERR GAIN):** Use only after sensitivity and all of the above settings are set as well as they can be. Increase gradually if vertical speed changes are not smoothed enough; Decrease if ride is too harsh. G Error Gain adjustments affect the most noticeable changes while the aircraft is in turbulence. The default setting is 10.
- **G Error Limit (G ERR LIM):** Use only after sensitivity and all of the above settings are set as well as they can be. Controls the max additional G the autopilot will push or pull to control vertical speed (up to the G limiter). G Error Limit adjustments affect the most noticeable changes while the aircraft is in turbulence. The default setting is 25.

Step 4c – Set Airspeed Minimum: The PITCH SERVO > AIRSP MIN parameter must be set to at least (and defaults to) 30% above V_{S1} , which should be set to the specifications of your aircraft in the EFIS > SETUP > IASCLR menu. The AP cannot be engaged at airspeeds below Airspeed Minimum, with the exception of 0 knots, allowing for ground testing. When flying at airspeeds lower than AIRSP MIN, the AP status indicator displays “SPD” for both axes, and cannot be engaged.

When the AP is engaged and aircraft airspeed drops below the minimum, the AP enters an airspeed hold mode, sacrificing altitude hold performance to maintain the minimum airspeed.

When the aircraft’s altitude drops below the target ALT bug and the AP cannot pitch the aircraft up without dropping below the minimum airspeed, the EFIS presents the prompt:

MIN AIRSPEED – ADD POWER

Airspeed Minimum is specified in knots, kilometers/hr, or miles/hr, depending on the units chosen in the EFIS > SETUP > UNITS > IAS menu. Minimum/default: 30% above V_{S1} .

To set the AIRSP MIN, perform the following (continuing from Pitch Servo Sensitivity):

- DOWN▼ > (AIRSP MIN: value is highlighted)
- Press DEC - and INC + to adjust APRSP MIN to preferred *initial* setting for the aircraft.

Step 4d – Set Pitch Servo Airspeed Maximum: The PITCH SERVO > AIRSP MAX parameter cannot be set to a value above 95% of V_{NE} , which should be set to the specifications of your aircraft in the EFIS > SETUP > IASCLR menu. The AP cannot be engaged at airspeeds above Airspeed Maximum. When flying at airspeeds above AIRSP MAX, the AP status indicator displays “SPD” for both axes, and cannot be engaged.

When the AP is engaged and aircraft airspeed rises above the maximum, the AP enters an airspeed hold mode, pitching the aircraft up to prevent exceeding the maximum airspeed.



When the aircraft's altitude rises above the target ALT bug and the AP cannot pitch the aircraft down without going above the maximum airspeed, the EFIS presents the prompt:

MAX AIRSPEED – REDUCE POWER

Airspeed Maximum is specified in knots, kilometers/hr, or miles/hr, depending on the units chosen in the EFIS > SETUP > UNITS > IAS menu. Maximum/default: 5% below V_{NE} .

To set the AIRSP MAX, perform the following (continuing from AIRSP MIN):

- DOWN▼ > (AIRSP MAX: value is highlighted)
- Press DEC - and INC + to adjust AIRSP MAX to preferred *initial* setting for the aircraft.

Step 4e – Set Pitch Servo VSPD Maximum: The PITCH SERVO > VSPD MAX parameter is specified in feet/minute (or meters/second, if the setting chosen in the EFIS > SETUP > UNITS > ALT is METERS). This parameter sets the average vertical speed the autopilot will command for climbs and descents. If you set this value above a vertical speed the aircraft can achieve, the AP will run into the airspeed limiter in climbs and descents. Minimum: 100 feet/minute; default: 500 feet/minute; maximum: 4,000 feet/minute.

On the EFIS, perform the following (continuing from Pitch Servo Airspeed Maximum):

- DOWN▼ > (VSPD MAX: value is highlighted)
- Press DEC - and INC + to adjust VSPD MAX to preferred *initial* setting for the aircraft.
- > BACK > EXIT

STEP 5 – DISENGAGE/CWS BUTTON CONFIGURATION

We recommend that you perform the following on the ground at zero airspeed.

Step 5a – Enable/Disable Hold to Engage: Setting HOLD TO ENGAGE to Y allows you to engage the Autopilot by holding the Disengage/CWS Button for more than 2 seconds. This allows for a convenient alternative to engaging the Autopilot via the menus and/or AP74 AP button. Default is N.

When this mode is active, anytime the autopilot is disengaged you can engage it by pressing and holding the Disengage/CWS Button for more than 2 seconds. Note that after 2 seconds, the AP status indicator at lower left of the EFIS screen shows **AP:CWS-CWS**. This indicates that the servos are in Control Wheel Steering mode and are waiting for the button to be released before engaging.

Step 5b – Enable/Disable Broken Disengage Line Detect: The BUTTON CONFIG > RESISTOR INST parameter should only be set to Y if the optional 5 k Ω resistor is installed across the Disengage/CWS Button, as shown on page 6-3. If the resistor is installed and this parameter is set to Y, the EFIS continuously monitors the AP Disengage/CWS Button circuit for proper resistance. If a broken line is detected the following message is displayed on the EFIS:

AUTOPILOT DISCONNECT LINE BROKEN

If the AP is engaged when this condition is detected, it will remain engaged.

Set to Y if the optional 5 k Ω resistor is installed across the 2 terminals of the Disengage/CWS Button. Set to N if the resistor is not installed. Default is N.



Step 5c – Enable/Disable Control Wheel Steering: When set to Y, the BUTTON CONFIG > CTRL WHEEL STEER > ENABLED option enables a secondary mode of the AP Disengage/CWS Button. This mode allows you to be flying under AP control, press *and hold* the Disengage/CWS Button while flying to a new heading and/or altitude, then release the button to reengage the Autopilot. The Autopilot will reengage in the mode set by the MODE parameter, described below. Default is N

On the EFIS, perform the following (continuing from Button Configuration Resistor Installed):

- DOWN▼ > (-CTRL WHEEL STEER- ENABLED: value is highlighted)
- SEL▶ > Set to Y or N per the explanation above.

Step 5d – Set Control Wheel Steering Mode: When the Control Wheel Steering ENABLED parameter is set to Y, the MODE parameter selects between two different ways of reengaging the Autopilot after the AP Disengage/CWS Button is released:

- Last Heading and/or Altitude (LAST HDG/ALT) - the AP is engaged and returns to the selected Heading and/or Altitude
- Hold Heading and/or Altitude (HOLD HDG/ALT) - the AP is engaged and changes the selected Heading and/or Altitude to match the current Heading and/or Altitude

Default is HOLD HDG/ALT.

On the EFIS, perform the following (continuing from Button Configuration Control Wheel Steer Mode):

- DOWN▼ > (-CTRL WHEEL STEER- MODE: value is highlighted)
- SEL▶ > Set to HOLD HDG/ALT or LAST HDG/ALT per the explanation above.
- > BACK > EXIT

**STEP 6 - AUDIO ALERTS CONFIGURATION**

AP74 This section applies only if you have installed the optional AP74.

The optional AP74 can act as the sole audio alert source for all DSAB-connected Dynon instruments. The audio output of the AP74 reports both EFIS and EMS alerts; each type of alert can be configured to be either voice or tone formats. When the AP74 is connected to your system, audible alerts are still generated by both EMS- and EFIS-based instruments. If you would like the AP74's audio out to be your only source for Dynon product audible alerts, disconnect the audio out connections on your other DSAB-connected Dynon products.

HS34 The AP74 and HS34 have identical voice output capabilities. If an HS34 Voice/Tone output is already connected to the aircraft intercom, *do not connect* the AP74 Voice/Tone output. *If the Voice/Tone output of both an HS34 and an AP74 are connected in parallel, audio alerts will be distorted.*

To configure AP74 audio alerts, enter the EFIS > SETUP > AP menu, scroll down to AUDIO ALERTS, and press SEL▶. The following points describe the options available for each setting:

EMS: EXT TONE / EXT VOICE – Sets whether you want the AP74 to report tones or voice alerts during EMS alarm conditions. This setting has no effect on the “direct” audio output of the EMS.

EFIS: EXT TONE / EXT VOICE – Sets whether you want the AP74 to report tones or voice alerts during EFIS alarm conditions. The “direct” audio output of the EFIS is muted*.

EFIS: EFIS TONE – tones are generated through the “direct” audio output of the EFIS and the audio output of the AP74 is muted.

AOA: EXT TONE – During an AOA alarm condition, tones are generated through the AP74 audio output and the EFIS “direct” audio output is muted*.

AOA: EXT VOICE – During an AOA alarm condition, voice is generated through the AP74 audio output simultaneously with a “progressive” tone from the EFIS “direct” audio output.

AOA: EFIS TONE – Tones are generated through the “direct” audio output of the

EMS AUDIO ALERTS
RPM HIGH
MANIFOLD PRESSURE HIGH
OIL PRESSURE HIGH/LOW
OIL TEMPERATURE HIGH/LOW
EGT [1..6] HIGH/LOW
EGT SPAN
CHT [1..6] HIGH/LOW
CHT SPAN
CHT [1..6] SHOCK
FUEL LEVEL [1..4] LOW
FUEL PRESSURE HIGH/LOW
FUEL FLOW HIGH
VOLTAGE HIGH/LOW
CURRENT HIGH/LOW
COOLANT TEMPERATURE HIGH
COOLANT PRESSURE HIGH/LOW
<i>All other EMS alerts vocalized “EMS ALERT”</i>
EFIS AUDIO ALERTS
ALTITUDE (Altitude alerter)
CLIMB/DESCEND (Altitude alerter)
AUTOPILOT DISCONNECT
STALL
TIMER EXPIRED
DSAB ERROR



EFIS and the audio output of the AP74 is muted.

* If an AP74 failure is detected during this condition, the EFIS “direct” audio output (tones only) is automatically re-enabled (fail-over).

Selecting TEST VOICE OUTPUT and then pressing SEL ► produces an audible voice test (“DYNON AVIONICS”) on the audio output line. This allows you to verify connections and volume on the ground. Turn the potentiometer to adjust the volume to your preference.

- ! If an AP74 is not connected or not configured for DSAB, the following message is displayed:

```
THIS SETUP MENU IS
DISABLED BECAUSE
NO AP74/76
CONNECTED
```

STEP 7 – PREPARE FOR FLIGHT TEST ON CLEAR, VFR DAY

- ! The remaining configuration steps are done while flying. At many points, the pilot’s attention will be divided between documentation, configuring the EFIS, and maintaining situational awareness. Before commencing these configuration steps, ensure that you have adequate altitude, clear weather, no traffic, no obstructions in the flight path, great visibility, etc. **If possible, bring someone along on the first configuration flight.**

If AP behavior, performance, or interference with the controls is cause for concern while flying, remember that the AP can be disengaged in any of the following ways:

1. Turn off the AP circuit breaker/switch or remove the fuse.
2. Push the Autopilot Disengage pushbutton.
3. In the EFIS, Select AP > HDG **ON** - push to turn off Roll servo (changes to HDG **OFF**); ALTON - push to turn off Pitch servo (changes to ALT **OFF**)
4. If you have an AP74 installed, push the AP button (The AP indicator turns off, but the Mode “armed” lights remain on).

Before commencing the remaining AP configuration steps, verify (on the ground with 0 airspeed indicated on the EFIS) that the AP status indicator displays (for a 2-axis system):

```
AP:OFF-OFF
```

Verify the following if you have a GPS installed, configured, and powered on:

- Magenta GPS information is displayed on the HSI page.
- In the EFIS > AP > MODE menu, *both* the HDG and TRK options are displayed.



STEP 8 – ROLL SERVO FLIGHT TUNING

This set of procedures tunes the settings in the AP > ROLL SERVO menu for the particular flight characteristics of the aircraft in heading holds and turns.

Note: While this procedure is described assuming you are using HDG mode – where the AP's goal is to keep the aircraft's magnetic heading aligned with the HDG bug – it can be performed in TRK mode – where the AP's goal is to keep the aircraft's ground track aligned with the bug – instead.

Step 8a – Verify preferred Turn Rate Limit and Bank Angle Limit

On the EFIS, perform the following:

- SETUP > AP > ROLL SERVO
- Verify that the TRN RT LMT and BANK LIMIT parameters are set to values you are comfortable with.
- If you wish to change either of these values prior to or during flight, push DOWN▼ to select the value, and then DEC - or INC + to modify it.

Step 8b – Ensure that the aircraft is in trim.

Because this test procedure tunes only the Autopilot's control of roll (so that roll performance can be isolated), only start the procedure when the aircraft is in neutral trim. During the following procedures, ensure that your altitude stays constant.

Step 8c – Engage the AP in HDG mode

On the EFIS, perform the following:

- EFIS > AP > HDG **OFF**.
- The EFIS synchronizes the HDG bug to the current heading, the Autopilot engages with the heading bug as its target, and the indicator turns to HDG **ON**.

AP74 If you have an AP74 installed and configured, the following performs the same function:

- Push HDG button (activates ROLL servo); ensure that the red HDG indicator lights are on.
- Ensure that the ALT indicator lights are **off**; push the ALT button if they are not.
- Push the AP button to engage in HDG mode.
- The AP status indicator at the lower left of the EFIS screen displays: AP: **HDG**-OFF

Step 8d – Allow a few minutes of stable flight under AP control

Note that the AP is only flying in Heading Hold Mode, so you will need to control the aircraft in pitch. Ensure that you are not affecting the Autopilot's control of the roll axis, so you can determine the AP's heading hold and change performance.

Step 8e – Adjust roll servo TORQUE and/or SENSITIVITY values as needed

On the EFIS, observe the AP status indicator (lower left corner - AP: **HDG**-OFF) while the AP flies. If the HDG indicator is *frequently* highlighted **yellow**, that is an indication that the Roll Servo is slipping and the torque needs to be increased. Occasional slips due to turbulence are acceptable.

If necessary, adjust the TORQUE value in the EFIS > SETUP > AP > ROLL SERVO menu.

- ❗ If you have adjusted the roll servo TORQUE value to 100% and are still seeing frequent slips, you may need to move the linkage attachment point on the roll servo 1 hole closer to the shaft. When doing this, take all precautions to ensure that an over center condition cannot occur, while still preserving the control surfaces' full range of motion. If a mechanical solution is not possible, you may wish to try a higher strength servo (e.g., if you have an SV32 installed, try swapping for an SV42).

After verifying that the TORQUE value is set appropriately, watch closely for AP “wandering” around the target heading or track. The AP should keep the inverted triangle of the heading bug closely aligned with the triangle of the numerical magnetic heading indicator (as shown at right). If flying in TRK mode, the AP should keep the inverted triangle of the bug (colored magenta to signify GPS mode) aligned with the magenta triangle of the current ground track.



- ❗ If excessive wandering is observed, increase the SENSITIVITY parameter in the EFIS > SETUP > AP > ROLL SERVO menu. If the AP control seems “twitchy” or aggressive, decrease the SENSITIVITY value. All adjustments of SENSITIVITY should be done in increments of 1 or 2, allowing you to notice subtle changes in control.

Step 8f – Change the heading bug 90 degrees from the current heading

Change the HDG bug to 90 degrees to the left or right of current heading via any of these methods:

- On the EFIS, enter the EFIS > AP > BUGS > HDG menu, and press INC + or DEC - to set desired heading.

AP74 On the AP74, press the VALUE knob (or just begin rotating knob, if you have configured the VALUE KNOB settings to allow for that) until the HDG bug adjustment window is displayed. Rotate the knob until the desired target heading is set.

HS34 On the HS34, rotate the HEADING knob.

As soon as the heading bug is changed, the AP begins changing the aircraft’s direction to follow.

Step 8g – Verify roll TORQUE and SENSITIVITY settings during turn(s)

During an AP-commanded turn, observe the AP status indicator as you did in step 8e; if excessive slipping is observed (indicated by a yellow highlight around the HDG status), then increase the roll servo’s TORQUE parameter.

Repeat the 90 degree AP-commanded turns and torque adjustments until the HDG indicator does not display a slip indication.

Continue performing AP-commanded turns, and observe the overall behavior of the aircraft. If the aircraft wallows, or rolls out of turns slowly as it reaches the target heading, that is an indication that the Roll Servo SENSITIVITY needs to be *increased*. If, upon reaching the target heading and the stick “twitches” excessively, that is an indication that the Roll Servo SENSITIVITY needs to be *decreased*.



- ! You should be able to find a SENSITIVITY value that is acceptable for both heading holds and turns in smooth air. You may, however, find that in periods of extended turbulence, a lower SENSITIVITY value must be set.

Step 8h – Verify TRN RT LMT and BANK LIMIT settings during turn(s)

During an AP-commanded turn, verify that the time to complete a turn matches your expectations given the setting for the TRN RT LMT parameter. For example, when TRN RT LMT is set to 3°/s, a 90° turn should take about 30 seconds. If this is not the case, the bank angle required by the target turn rate may *exceed* the set BANK LIMIT parameter. Ensure that during an AP-commanded turn, the bank angle indicated on the EFIS screen does not reach the angle set in the BANK LIMIT parameter. If it does, you must either increase BANK LIMIT or decrease TRN RT LMT.

At this point, all the parameters in the AP > ROLL SERVO menu are properly tuned.

Step 8i – Disengage AP

On the EFIS, perform either of the following:

- In the EFIS > AP menu, press the HDG~~ON~~ (or TRK~~ON~~) button, toggling off the roll servo **AP74**. On the AP74, press the AP button. The AP status lights on AP button turn off.

STEP 9 – PITCH SERVO FLIGHT TUNING

This set of procedures tunes the settings in the AP > PITCH SERVO menu for the particular flight characteristics of the aircraft in altitude holds, climbs, and descents.

Step 9a – Verify preferred Airspeed Min/Max and Vertical Speed Max

On the EFIS, perform the following:

- SETUP > AP > PITCH SERVO
- Verify that the AIRSP MIN, AIRSP MAX, and VSPD MAX parameters are set to values you are comfortable with.
- If you wish to change any of these values prior to or during flight, push DOWN▼ to select the value, and then DEC - or INC + to modify it.

Step 9b – Ensure that the aircraft is in trim.

Step 9c – Engage the AP in ALT mode

On the EFIS, perform the following:

- EFIS > AP > ALT~~OFF~~.
 - The EFIS synchronizes the ALT bug to the current altitude, the Autopilot engages with the heading bug as its target, and the indicator turns to ALT~~ON~~.
- AP74** If you have an AP74 installed and configured, the following performs the same function:
- Push ALT button (activates PITCH servo); ensure that the red ALT indicator lights are on.
 - Ensure that the HDG indicator lights are **off**; push the HDG button if they are not.
 - Push the AP button to engage in ALT mode.
 - The AP status indicator at the lower left of the EFIS screen displays: AP:OFF-~~ALT~~

Step 9d – Allow a few minutes of stable flight under AP control

Note that the AP is only flying in Altitude Hold Mode, so you will need to control the aircraft in roll. Ensure that you are not affecting the Autopilot’s control of the pitch axis, so you can determine the AP’s altitude hold and change performance.

Step 9e – Adjust pitch servo TORQUE and/or SENSITIVITY values as needed

On the EFIS, observe the AP status indicator (lower left corner - AP:OFF-**ALT**) while the AP flies. If the ALT indicator is *frequently* highlighted **yellow**, that is an indication that the Pitch Servo is slipping and the torque needs to be increased. Occasional slips due to turbulence are acceptable.

If necessary, adjust the TORQUE value in the EFIS > SETUP > AP > PITCH SERVO menu.

- ❗ If you have adjusted the pitch servo TORQUE value to 100% and are still seeing frequent slips, you may need to move the linkage attachment point on the pitch servo 1 hole closer to the shaft. When doing this, take all precautions to ensure that an over center condition cannot occur and that the servo can provide the necessary travel for your system. If a mechanical solution is not possible, you may wish to try a higher strength servo (e.g., if you have an SV32 installed, try swapping for an SV42).

After verifying that the TORQUE value is set appropriately, watch closely for AP “wandering” around the target altitude. The AP should keep the inverted triangle of the altitude bug closely aligned with the triangle of the numerical magnetic altitude indicator (as shown at right).



- ❗ If excessive wandering is observed, increase the SENSITIVITY parameter in the EFIS > SETUP > AP > PITCH SERVO menu. If the AP control seems “twitchy” or aggressive, decrease the SENSITIVITY value. All adjustments of SENSITIVITY should be done in increments of 1 or 2, allowing you to notice subtle changes in control.

Step 9f – Initiate AP-controlled climbs and descents

Change the ALT bug to 500 feet above your current altitude via any of these methods:

- On the EFIS, enter the EFIS > AP > BUGS > ALT menu, press SEL▶ to highlight the hundreds digit, and press INC + to set desired altitude.

HS34

AP74

On the AP74 or HS34, press the VALUE knob (or just begin rotating knob, if you have configured the VALUE KNOB settings to allow for immediate adjustment of the altitude bug) until the ALT bug adjustment window is displayed. Rotate the knob until the desired target altitude is set.

As soon as the altitude bug is changed, the AP begins changing the aircraft’s altitude to follow.

Repeat this step, setting the altitude bug to 500 feet below your current altitude.

Step 9g – Verify pitch TORQUE and SENSITIVITY settings during climbs and descents

During an AP-commanded climb, observe the AP status indicator as you did in step 9e; if excessive slipping is observed (indicated by a yellow highlight around the ALT status), then increase the pitch servo’s TORQUE parameter. Repeat this verification in a descent.



Repeat the AP-commanded climbs/descents and torque adjustments until the ALT indicator does not display a slip indication.

Continue performing AP-commanded climbs and descents, and observe the overall behavior of the aircraft. If the aircraft oscillates in holds or overshoots as it reaches target altitude, that is an indication that the Pitch Servo SENSITIVITY needs to be *increased*. If, upon reaching the target altitude the stick “twitches” excessively, that is an indication that the Roll Servo SENSITIVITY needs to be *decreased*.

- ! You should be able to find a SENSITIVITY value that is acceptable for altitude holds, climbs, and descents in smooth air. You may, however, find that in periods of extended turbulence, a lower SENSITIVITY value must be set.

Step 9h – Verify AIRSP MIN/MAX, and VSPD MAX settings during altitude changes

During an AP-commanded climb, verify that the time to complete the climb matches your expectations given the setting for the VSPD MAX parameter. For example, when VSPD MAX is set to 500 ft/min, a 500-foot climb should take about 1 minute. If this is not the case, the climb rate may be limited by the AIRSP MIN parameter, and the ADD POWER message is displayed.

Likewise, during an AP-commanded descent, verify that the time to complete the descent matches your expectations given the setting for the VSPD MAX parameter. If it does not, the descent rate may be limited by the AIRSP MAX parameter, and the DECREASE POWER message is displayed.

If necessary, adjust the AIRSP MIN, AIRSP MAX, and VSPD MAX parameters as described above.

At this point, all the parameters in the AP > PITCH SERVO menu are properly tuned.

Step 9i – Execute several AP-controlled changes of altitude and observe the overall aircraft performance.

There may be some interaction between Pitch Servo Torque and Pitch Servo Sensitivity settings. Repeat the above steps as necessary to achieve acceptably smooth overall AP response during altitude holds and changes.

Step 9j – Observe and verify trim indications during altitude holds and changes

Find an area with a lot of clearance above and below the aircraft’s altitude. With the AP disengaged, put the aircraft into neutral trim. Engage the AP in ALT mode (and HDG or TRK mode if desired) and allow the AP to maintain altitude (and heading, if engaged). Trim the aircraft nose down; the AP will maintain the target altitude, despite the nose down trim. Continue trimming nose down **just until** a yellow UP▲ indicator displays (and stays on) next to the AP status indicator at the lower left of the EFIS screen (shown at right). This indicator displays when the AP senses too much nose down trim. Trim the aircraft nose up until the indicator disappears. Disengage the AP to observe the state of the aircraft’s trim.



Repeat the above procedure, trimming the aircraft nose up until the yellow DN▼ indicator displays (and stays on). Then, trim nose down until the indicator disappears.

During turbulence and small bumps the trim indicator may flash on and off. Do not take action based on the trim indicator until it remains on for several seconds.

STEP 10 – VERIFY OVERALL AP PERFORMANCE

Engage both roll and pitch servos and execute a number of AP-controlled changes of heading, altitude, and combinations of the two and observe the overall aircraft performance under AP control. There may be some interaction between the various Pitch Servo and Roll Servo settings. Repeat portions of steps 9 and 10 as necessary to fully “dial in” the AP for overall smooth flight performance under AP control.

AP74 Configuration

If you have the AP74 installed, you may configure the way it controls the autopilot, barometer setting, and bug values. This configuration is done in the **SETUP > AP > AP74/76 SETTINGS menu**. The following sections describe the configuration in this menu.

VALUE KNOB CONFIGURATION

The VALUE knob changes the BARO, ALT bug, and HDG bug settings and is configured in the -VALUE KNOB- portion of this menu.

The VALUE knob can be configured to require an initial push before rotating the knob has any effect (REQUIRE PUSH: YES / NO).

The default mode of the VALUE knob is configured by setting FIRST ACTION: to ALT, HDG, or BARO. This configures whether the altitude bug, heading bug, or barometer is the first action to be adjusted by the knob.

If REQUIRE PUSH is set to YES:

- The first push of the VALUE knob activates the FIRST ACTION mode (ALT, HDG or BARO) and displays a “pop-up” window indicating the current mode and value. Rotating the knob within 5 seconds changes the value of the FIRST ACTION mode. A second push of the VALUE knob within 5 seconds after rotating the knob de-activates the VALUE knob and closes the pop-up window. If there is no further action (either a knob push or knob rotation), the VALUE knob automatically de-activates (times out) after 5 seconds and closes the pop-up window.
- If, after the first push of the VALUE knob, the knob is *not* rotated, subsequent pushes cycle through the 2nd and 3rd settings in the rotation, in the order BARO, HDG, ALT, <off>.

If REQUIRE PUSH is set to NO:

- Rotating the VALUE knob changes the value of the FIRST ACTION mode (ALT, HDG, or BARO) and displays a pop-up window indicating the current mode and value. Pushing the VALUE knob again within 5 seconds of the last knob rotation closes the pop-up window.
- Pushing the VALUE knob without first rotating it cycles through the remaining modes (not chosen by FIRST ACTION above). Pushing the VALUE knob cycles through these modes in the order BARO, ALT, HDG, <off>.
- If there is no further action (either a knob push or knob rotation) within 5 seconds, the pop-up window automatically closes.



PRE-SELECT CONFIGURATION

In the -BUGS- section of the AP74/76 SETTINGS menu, you can choose when the heading and altitude bugs should be synchronized to their respective current values:

- **ON ENGAGE:** The HDG and ALT bugs are synchronized to the heading and altitude values each time the AP is engaged (via the AP button on the AP74 or in the EFIS AP menu). This is the default setting.
- **ON MODE ARM:** The HDG and ALT bugs are synchronized when their respective mode is armed. When the HDG or TRK buttons are pushed on the AP74, the HDG/TRK bug is synchronized to the current heading. When the ALT button is pushed on the AP74, the ALT bug is synchronized to the current altitude. When the autopilot is engaged, the bug settings are not modified. This allows you to enter a desired heading and/or altitude prior to engaging the AP.
- **NEVER:** The HDG and ALT bugs are never automatically modified by turning on the AP or changing AP modes. Be aware that the bugs are highly likely to be set far away from the current heading and altitude at the time of AP engagement; **this will result in the AP immediately commanding a turn and a climb or descent at time of engage. When using this mode, we recommend that you verify the EFIS' bugs settings prior to EVERY Autopilot engage.**

MODE CLEARING CONFIGURATION

In the -CLEAR MODES- section, you can configure whether the autopilot clears the active modes (HDG, TRK, or NAV; and ALT) on AP disengage. If you select NO, the AP leaves the mode(s) pre-armed when the AP is off. This leaves the last-used roll mode (HDG, TRK, or NAV) and/or pitch mode (ALT) lights lit on the AP74. You may, of course, switch to new modes prior to re-engaging the AP. If you select YES, the AP disarms all modes upon disengaging the AP, turning off all mode lights on the AP74. You must then select the active modes prior to re-engaging the AP (although if no modes are pre-armed, pressing the AP button causes the HDG mode to be engaged by default).

Clearing modes on disengage is most useful when used in conjunction with the ON MODE ARM pre-select configuration above. This forces you to explicitly enable (and thus synchronize) the modes you wish the autopilot to control when you press the AP button.

The default value for this setting is NO, leaving all modes pre-armed after turning off the AP.

7. APPENDIX

The appendices contain additional information pertaining to the installation and maintenance of the EFIS-D100. You will find here a table of weights, specifications, a configuration table, the maintenance manual, the OAT Installation and Operating Guide, the AOA Pitot Installation Guide, and the Blind encoder Serial-to-Parallel Installation Guide.

Appendix A: Ongoing Maintenance and Troubleshooting

INTRODUCTION

This section gives the installer or mechanic information pertaining to maintenance of the EFIS-D100. Additionally, it provides the steps necessary to ensure continued airworthiness for the unit.

CAUTION

With the exception of replacing the internal emergency battery, the EFIS-D100 contains no user-serviceable parts. Refer all servicing to Dynon Avionics.

INSTRUCTIONS FOR CONTINUED AIRWORTHINESS

Other than for regulatory periodic checks and an annual internal battery capacity test (if optional internal emergency battery is installed), maintenance of the EFIS-D100 is “on-condition” only. With the exception of the battery, periodic maintenance of the EFIS-D100 is not required.

AP SERVO INSTALLATION

At least once per year, inspect the installation of the AP servo(s) for excessive wear. Ensure that all hardware and fasteners are tightly secured.

ALTIMETER CHECK

The following test can be performed on an as-needed basis. If the altimeter is found to be out of specification, the following single-point adjustment can be performed by navigating the menus to SETUP > ALTADJ. In the Altimeter Adjustment menu, you can change the displayed altitude by up to 500 feet up or down. After making this adjustment, ensure that the altimeter on the EFIS-D100 meets the tolerances allowed between 0 and 30,000 feet. If this adjustment does not bring the altimeter on the EFIS-D100 to within specification at all attitudes, please contact Dynon Avionics to return for service.

INTERNAL BATTERY CHECK

If your EFIS-D100 has a rechargeable internal emergency battery, it is necessary to ensure that the battery capacity is such that it will last at least 2 hours on a full charge. At least once per year, perform the following test.

1. With the EFIS-D100 drawing power from an external source, allow it to charge its internal battery above 16.0 volts. Observe the voltmeter under the INFO selection option in the menu system. The battery may charge to as high as 16.8 volts, but it is only necessary to charge it to 16.0 volts for this test.



2. Remove all sources of external power from the EFIS-D100, ensuring that it is operating off its internal battery.
3. Ensure that the screen is at its full brightness level. To do this, enter the menu system by pressing any button beneath an EFIS page (except the far left or far right hotkeys) and press MORE > DIM and increase the brightness until it will not increase anymore.
4. Let the unit remain on for 2 hours.
5. If, after these 2 hours, your EFIS-D100 has not turned off and does not display the INTERNAL BATTERY LOW warning, your battery passes the capacity test.
6. Make sure you recharge your battery; a full charge is reached when the voltmeter shows at least 16.0 volts on the internal battery.

If your battery does not pass the above test, please contact Dynon Avionics and refer to Appendix E for battery replacement instructions.



Please dispose of non-functional backup batteries in a responsible manner. Backup batteries are lithium-ion and similar in construction to cordless tool batteries. They can likely be recycled wherever cordless tool battery recycling is available. For a list of recycling locations in your area (USA only), call 1-800-8-BATTERY or see the Call 2 Recycle website at www.rbrc.org.

FIRMWARE UPGRADE

Dynon Avionics provides free firmware updates for all its products, and continues to add new features periodically. We suggest that you regularly ensure that your EFIS-D100 has the latest firmware by visiting our website at downloads.dynonavionics.com and downloading the latest Dynon Product Support Program. This software contains the latest firmware updates for all our products.

Each Dynon EMS or EFIS must be individually upgraded by connecting a PC to that instrument's serial port. The HS34 also must be individually upgraded via its Serial 1 port. Firmware upgrades to EDC-D10A, AP74, and SV32/42/52 are performed automatically during firmware upgrades of the attached EFIS product. (Upgrading a non-DSAB-bus-master EFIS will not update attached autopilot devices).

DISPLAYED ALERT MESSAGES

The following table describes the alert messages that the EFIS-D100 can display.

Alert Message	Description	End condition
INTERNAL ERROR SERVICE UNIT	This error can occur for a few reasons, including an aborted upload. It signifies that the EFIS-D100 has detected internal problems in its firmware or calibration tables.	When this error appears, it may be possible to recover your unit in the field. The best way of ensuring this is to call Dynon Avionics immediately. However, there is a good possibility that the unit will have to be returned for service.



Alert Message	Description	End condition
ATTITUDE RECOVERING...	This alert is displayed anytime the unit is rotated at a rate faster than 150 degrees/second or the unit is powered on with airspeed applied. Rotating the unit faster than this threshold will saturate the gyros, leading to potentially erroneous display. The blue/brown horizon indication will turn grey and black to indicate that the artificial horizon is not currently a trusted source. Note that this alert only appears when airspeed is non-zero; using the EFIS-D100 on the bench will not trigger this alert.	The grey/black horizon indication and onscreen message will remain until the unit has resumed normal operation. In the case of rotation rate greater than 150 degrees/second, the unit enters a fast recovery mode and usually recovers within 5 seconds of coordinated flight.
TEMPERATURE UNSTABLE	When the unit is turned on after having been off for a long period, its internal temperature will rise above ambient at a fast rate. This fast change in temperature can sometimes reduce the reliability of the output of the sensors. Therefore, this alert is displayed and the horizon indication is changed from blue/brown to grey/black.	The screen remains normal color, but the message is displayed until the temperature within the unit has stabilized. This temperature instability should last no longer than 2 minutes. For this reason, it is a good idea to turn the unit on before you run through any of the preflight procedures, so that it will be ready by the time you are ready to fly.
TEMPERATURE OUT OF SPEC	The temperature inside the unit is outside of -30°C to 50°C.	The screen remains normal color, but the message is displayed until the temperature within the unit is within the specified range. This is most common in unventilated panels during hot periods. If you continue to see this alert, provide more airflow to the space around the EFIS-D100.



Alert Message	Description	End condition
INTERNAL BATTERY LOW	You will see this alert only when operating the unit solely off the internal backup battery. When its voltage has dropped below a certain threshold, you will see this alert. Additionally, the voltmeter will be displayed onscreen. When you see this alert, it is advisable that you turn the unit off by pressing the POWER button in Main Menu 1.	The alert will disappear when you press any button; however, it is advised that you do not ignore this alert, as it appears when the unit's internal battery has very little life left. This alert will also go away upon the application of either the external backup battery or Master Power. At that point, the battery will begin charging off the external power.
REMOTE COMPASS NOT DETECTED	The EFIS-D100 is unable to communicate with the EDC-D10A. If you have an OAT connected to your EDC-D10A, you will lose this reading, as well.	Ensure that you a) have an EDC-D10A installed and b) have verified that the wiring to the EDC-D10A is correct. Please see the EFIS-D100 Installation Guide for more information on verifying the installation of the EDC-D10A. This error also can appear if you have updated the firmware in your EFIS-D100 while the remote compass was <i>not</i> connected. If this is the case, try uploading the new firmware again with the EDC-D10A connected. Attempt the connection within the first few seconds of operation. Note that the EFIS-D100 does not have internal magnetic sensors and thus <i>requires</i> the EDC-D10A be connected.
OAT SENSOR NOT DETECTED	This alert appears when the EFIS has an OAT connected and then loses that connection for some reason. Either the EDC-D10A has become disconnected, or the OAT sensor itself has become disconnected from the EDC-D10A.	Double-check your wiring between the EFIS-D100 and the EDC-D10A as well as that of the OAT sensor.

TROUBLESHOOTING GUIDE

The following table provides a list of potential issues that the EFIS-D100 may experience. The symptom is given on the left side while the probable solution is listed at the right. You may also post about your issue at forum.dynonavionics.com, where we and other active users may be able to assist you.



Problem	Solution
After performing a magnetic calibration the EFIS-D100's heading is wrong by a constant amount.	Orient your plane in a known direction, preferably on a compass rose at the airport. Navigate to the Heading Adjustment menu by pressing SETUP > MORE > MORE > MAGADJ. Increment or decrement the value of the heading until the EFIS-D100 heading corresponds to the direction in which your plane is pointed.
When the barometer on the unit is set correctly, the displayed altitude is wrong by a constant amount at all altitudes.	Set the barometer to the correct value for your current location. Note the difference between the displayed altitude and the actual altitude for your location. Navigate to the Altitude Adjustment menu by pressing SETUP > MORE > ALTADJ. Increment or decrement the value of the altitude until the EFIS-D100 altitude corresponds to that of the current location of your plane. If you need to adjust by more than 200 ft, or find that you need to adjust frequently (after setting your baro), please call Dynon Technical Support for assistance.
Airspeed is inaccurate by between 1 and 10 knots (or equivalent, in other units) at takeoff speed.	You may recalibrate your EFIS-D100's zero pressure value. With your plane in as windless an environment as possible (e.g., a hangar), cover both the pitot and static ports with a sock or cloth to minimize airflow without putting pressure on the ports. Next, on the EFIS-D100, enter the EFIS main menu, press MORE > SETUP > MORE > MORE > MORE > SPDCAL. When you are confident that there is no pressure on the pitot and static ports, press either button corresponding to SET ZERO PRESSURE. Press YES to confirm you have zero pressure on the pitot and static ports. You will see a message indicating that the unit is calibrating. This should only take a few seconds. On your next flight, verify that the airspeed is what you expect. To reset the airspeed calibration to factory defaults, enter the SPDCAL menu, and press RESET DFLTS.
EFIS-D100 displays continuous or blinking blue screen	Ensure that your power supply is capable of supplying at least 2 amps and that it is at least 10 volts. If, after verifying that you have met these two conditions the unit does not operate normally, it is necessary to contact Dynon Avionics.
EFIS-D100 screen stays black when power is applied	Verify Master Power is connected. Verify Master Power is above 10 volts.
EFIS-D100 indicates over temperature condition	Provide additional cooling to instrument
EFIS-D100 indicates incorrect heading	(Re)calibrate the magnetic heading using the procedure described above.



Problem	Solution
Internal battery life is too short	Verify internal battery is charged to above 16 volts using EFIS-D100 voltmeter. Re-run capacity test. Replace battery if insufficient capacity.
Clock setting is lost	If present, verify internal battery is charged. If no internal battery, verify Keep Alive power is supplied to unit at all times.
Cannot make connection with PC	Verify wiring is correct. Verify no other programs using the COM port are running on the PC. Verify latest version of The Dynon Product Support Program is being used.

INSTRUCTIONS FOR RETURN

If none of the above sections have helped resolve an ongoing issue with your EFIS-D100, please call Dynon Avionics at 425-402-0433 to discuss the issue with Technical Support. If, after troubleshooting with a Dynon representative, the issue cannot be resolved, we will provide you with an RMA number to use when shipping the EFIS-D100 to us. If your unit is still under warranty, the repairs will be performed and the EFIS-D100 will be returned promptly. If your warranty has expired, the Dynon representative will make arrangements with you and make you fully aware of the costs before proceeding with the repair.

We recommend that you also send your EDC-D10A remote compass along with your EFIS-D100. This ensures that if we upgrade the firmware in your EFIS-D100, the EDC-D10A will have corresponding firmware.

While Dynon Avionics makes every effort to save and restore your unit's settings and calibrations, we cannot guarantee that this will happen. Please note that after you receive your unit back from Dynon Avionics with a factory calibration, the heading display on the EFIS-D100 may be inaccurate once re-installed in your aircraft. If this is the case, you will have to perform the magnetic calibration again. When you receive your EFIS-D100, it may have newer firmware installed on it than it did when you sent it in. Check downloads.dynonavionics.com for information on what's new.

Appendix B: Dynon OAT Probe Installation and Usage

Note that this section only applies to the OAT with 3 wires (colored red, yellow, and blue), for connection to the EDC-D10A. If you have the 2-wire OAT (with black/white wires), see one of the EMS-based Installation Guides for more information.

The following instructions provide information on installing and using the EFIS-D100 OAT probe. Keep in mind that this probe is designed specifically to work with the EFIS-D100. Do not expect it to work properly with another OAT or TAS/Density Altitude system. If you own a Dynon EMS product with an OAT installed, your EFIS-D100 can receive its OAT value from the EMS via the DSAB wires. See the Dynon Smart Avionics Bus (DSAB) Wiring section on page 3-11 for information on connecting the two instruments.

TOOLS AND MATERIALS REQUIRED

- Dynon Avionics OAT probe/cable with nylon nut and washer.
- Drill with 3/8" bit
- Dynon Avionics EDC-D10A remote compass module.
- 2 machined D-sub pins
- D-sub pin crimp tool
- Loctite

INSTALLATION

Mount Location

It is important that the OAT probe be mounted somewhere on the skin of the aircraft where it will not be affected by heat sources (sun, engine, aircraft interior, etc). The ideal location would receive no heat from the aircraft engine or any other source in the aircraft body. While this may be impractical, it is a good idea to mount the probe as far away from heat sources as possible. On the RV series, common locations include the wingtip and under the horizontal stabilizer. Avoid these three locations:

- Engine exhaust paths
- The engine itself
- Where the sensor will have direct sunlight
- Where the backside is exposed to a heated cabin

Mounting Instructions

After the mounting location has been determined, drill a 3/8" hole in the skin at the desired location. Uncoil the cable attached to the OAT probe. Remove the nylon nut from the cable. From outside the skin of the aircraft, insert the cable first and then the threaded end of the OAT probe. From within the skin of the aircraft, gently pull the cable until the threaded end of the OAT probe pokes through the hole. Thread the nylon nut down the cable and up to the threaded end of the OAT probe. Spread some Loctite around the threads of the OAT probe. Twist the nut onto the threads of the OAT probe and tighten.

Wiring Instructions.

Once you have physically mounted the OAT probe, route its attached cable to the EDC-D10A remote magnetic compass module. Your OAT comes with pins crimped on the 3 wires. Insert these 3 wires' pins to the following pin numbers on the D9 which plugs into the EDC-D10A. The front of the female connector is pictured at right. You will be inserting the pins into the back of this connector.

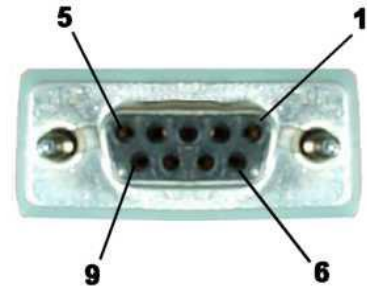

- Pin 2: Yellow wire
- Pin 7: Red wire
- Pin 8: Blue wire

The exposed shield wires are not strictly required, but may help OAT performance in noisy environments. If you wish to connect the shield to ground, you may splice it into the blue wire or connect it to the EDC-D10A chassis.

You may lengthen or shorten the connections between the OAT and EDC-D10A. Use the provided crimp connectors on the new wire leads.

! Do not make connections while the EFIS-D100 is powered!

OAT/TAS/DA DISPLAY

You must set up the EFIS-D100 to recognize the OAT. The EFIS-D100 supports two different types of OATs as well as a manual input of the outside temperature. To set this up, enter the menu system by pressing any button beneath an EFIS page, and press MORE > SETUP > MORE > OAT. Push the INSTALLED button (either button 1 or 2) to toggle between N, 1 and 2. All OATs sold by Dynon since 2005 are P/N 100433-001, so you most likely need to select sensor type 2.

Installed Type	Sensor
N	No OAT installed, dial in OAT value in OATSET menu
1	Dynon P/N 100240-000
2	Dynon P/N 100433-001– marked with a black band near the sensor

Note: Set the OAT INSTALLED parameter to N when you either: a) do not have an OAT at all or b) have an OAT connected to EMS D37 connector. If you do not have an OAT in the system at all, the OAT info item will be surrounded by a box denoting that its value can be adjusted manually.

To display the data from the OAT probe, press any button below an EFIS page to bring up the EFIS menu and press MORE > INFO. Select the side of the screen that you wish to display TAS/DA information on (LEFT or RIGHT). Push the button labeled OAT. The values for outside air temperature, density altitude and true airspeed will be shown.

CALIBRATION AND ADJUSTMENT

Before adjustment, it is possible for the OAT sensor to read as much as 5 degrees Celsius off the actual value. Therefore, it may be necessary to adjust the displayed air temperature value to compensate for this. To make this adjustment, you must enter the menu system and press the following sequence of buttons: MORE > SETUP > MORE > OAT. This will display the OAT adjustment menu. Press INC or DEC to increase or decrease the currently displayed OAT value.

It is important to make this adjustment when the air surrounding the OAT probe is at a known temperature. This can be achieved with a standard thermometer. Adjust the displayed OAT until it agrees with your independent temperature reference.

TROUBLESHOOTING

OAT value fluctuates wildly

If the OAT probe is improperly wired, the EFIS-D100 will not receive a valid signal from it. Verify that the three wires coming from the OAT probe are wired exactly as described in the Wiring Instructions section above.

OAT value is consistently high/low

You need to adjust the displayed OAT value to correct for sensor inaccuracies. Follow the instructions in the Calibration and Adjustment section above.

OAT display area states OAT NOT FOUND

Ensure that you have selected the number corresponding to your OAT in the OAT INSTALLED menu as described above. It can sometimes take as long as 5 seconds for the EFIS-D100 to lock onto the OAT reading. Ensure that all wiring is correct and that there are no shorted or open connections.

Other strange behavior by OAT reading

It is possible that your EFIS-D100 and EDC-D10A have mismatched versions of firmware on them. This most commonly happens when one takes the EFIS-D100 out of the aircraft to connect to a computer for firmware upgrade. Ensure that the EFIS-D100 and EDC-D10A are connected to each other and communicating before attempting a firmware upgrade.

Appendix C: HS34 Installation and Configuration

If you purchased an HS34 from Dynon Avionics, read through this section for details on its physical and electrical installation. It describes the pinout, mounting information, and some common wiring connections.

WIRING

Follow these instructions explicitly as improper wiring can result in permanent damage to your instrument, other connected equipment, or both. Read through the Recommended Wiring Practices section on page 2-1 before proceeding.

Harness Construction

Because the HS34 interfaces with such a wide variety of NAV radios and GPSs in different combinations of configurations, Dynon Avionics does not supply pre-manufactured harnesses for the HS34. Instead, your HS34 shipped with enough connectors and pins to generate a wide variety of harness configurations. Refer to the Pinouts and Function Description and Common Device Connections sections below for detailed wiring information.

If you do not own a D-sub machined-pin crimping tool, they can be obtained for under USD\$50 at www.bandc.biz (P/N RCT-3), www.steinair.com (P/N SAT-004), and many other tool retailers. You may also find it helpful to own a pin insertion/extraction tool, part numbers DSE-1 and SAT-023, respectively.

Power Requirements

22 AWG wire is normally sufficient for the power supply and ground lines, but you should consult a wire sizing chart and determine the size required for your routing length. Make sure you protect the power lines with either a circuit breaker or an appropriately sized fuse for the wire you select. Power is fed to the HS34 via pins in the male DB25 connector on the back of the instrument.

The HS34's power requirement is **2 watts** typical and **3 watts** maximum. On a 12-volt system, this translates to about 0.25 amps of maximum current draw. On a 24-volt system, this translates to about 0.13 amps maximum current draw. Normally, a 0.5-amp circuit breaker or fuse is sufficient.

Connector Description

The HS34 has two DB25 connectors on the rear of the instrument: one male and one female. **All references to connector gender in this guide are used to describe the connectors on the back of the HS34, not your harnesses.** When building harnesses for the HS34, make note of the fact that the pin order for the male connector is the opposite of the order for the female connector. Small pin numbers can be found next to each pin on both the instrument's and harness's connectors.

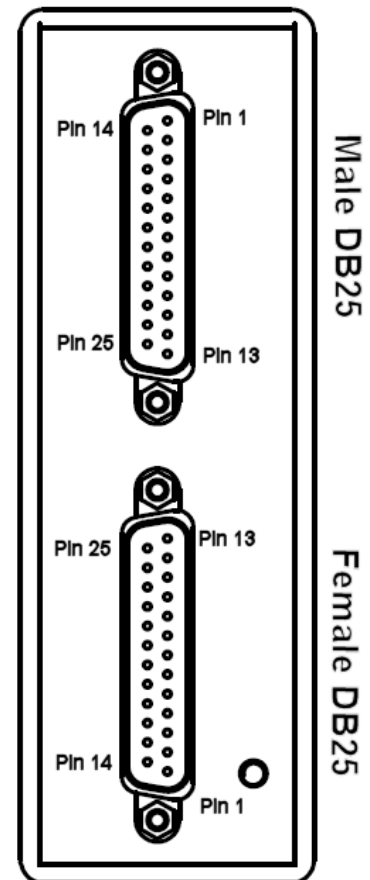

*Pinouts and Function Description*

Below are the pinouts and function descriptions for the HS34's male and female connectors. At a minimum, you must make the connections shown in the Universal Connections diagram. All other wiring connections depend on the external equipment you are connecting to the HS34. Many common radio and GPS connections are depicted in the Common Device Connections section below. *Note that the pin numbers are labeled on the face of both the female and male connector.*

Male (on HS34) DB25		Female (on HS34) DB25	
Pin#	Function	Pin#	Function
1	Serial 1 RX (PC updates & second serial port)	1	CDI + when deflected right
2	Serial 2 RX (SL30, GPS, etc)	2	VOR + when TO flag shown
3	DSAB A	3	LOC +
4	Master Power (10-30V, 250 mA maximum at 12V)	4	GS + when up UP
5	GP Output 1 (not currently supported)	5	GS + when FLAG shown
6	GP Output 2 (not currently supported)	6	DME Analog IN (0-8V, 40mv/NM)
7	GP 1 in (same as EMS GP in)	7	Resolver G
8	GP 2 in (same as EMS GP in)	8	Resolver D
9	+5V out	9	Resolver F
10	GP 6 in (+15V GP in, not currently supported)	10	ARINC 429 RX 2 B
11	GP 5 in (+15V GP in, not currently supported)	11	ARINC 429 RX 1 B
12	GP 4 in (+15V GP in, not currently supported)	12	ARINC 429 TX B
13	GP 3 in (same as EMS GP in)	13	ARINC 429 TX B
14	Serial 1 TX	14	CDI + when Left
15	Serial 2 TX	15	VOR + when From flag shown
16	DSAB B	16	LOC -
17	Master Ground	17	GS + when Down
18	Contact in 4 (same as EMS contacts)	18	GS + when Flag hidden
19	Contact in 3 (same as EMS contacts)	19	Resolver C
20	Contact in 2 (same as EMS contacts)	20	Resolver H
21	Contact in 1 (same as EMS contacts)	21	Resolver E
22	Marker Outer Input	22	ARINC 429 RX 2 A
23	Marker Middle Input	23	ARINC 429 RX 1 A
24	Marker Inner Input	24	ARINC 429 TX A
25	Voice audio output (8V peak-peak)	25	ARINC 429 TX A

Universal Connections

The following diagram shows the wiring connections that must be made in every HS34 installation. These required connections ensure that the HS34 can power on, communicate with other Dynon products, connect to a laptop for firmware uploads, and output audio alerts to your intercom system. Once properly configured on your DSAB network, this connection scheme allows you to use your HS34's VALUE knob with the DSAB Bus Master. Refer to the Dynon Smart Avionics Bus (DSAB) Wiring section on page 3-11 for more information on connecting Dynon products via DSAB. Refer to the DSAB Configuration section on page 5-1 to review the concepts involved in a networked system as well as an example system which includes an HS34.

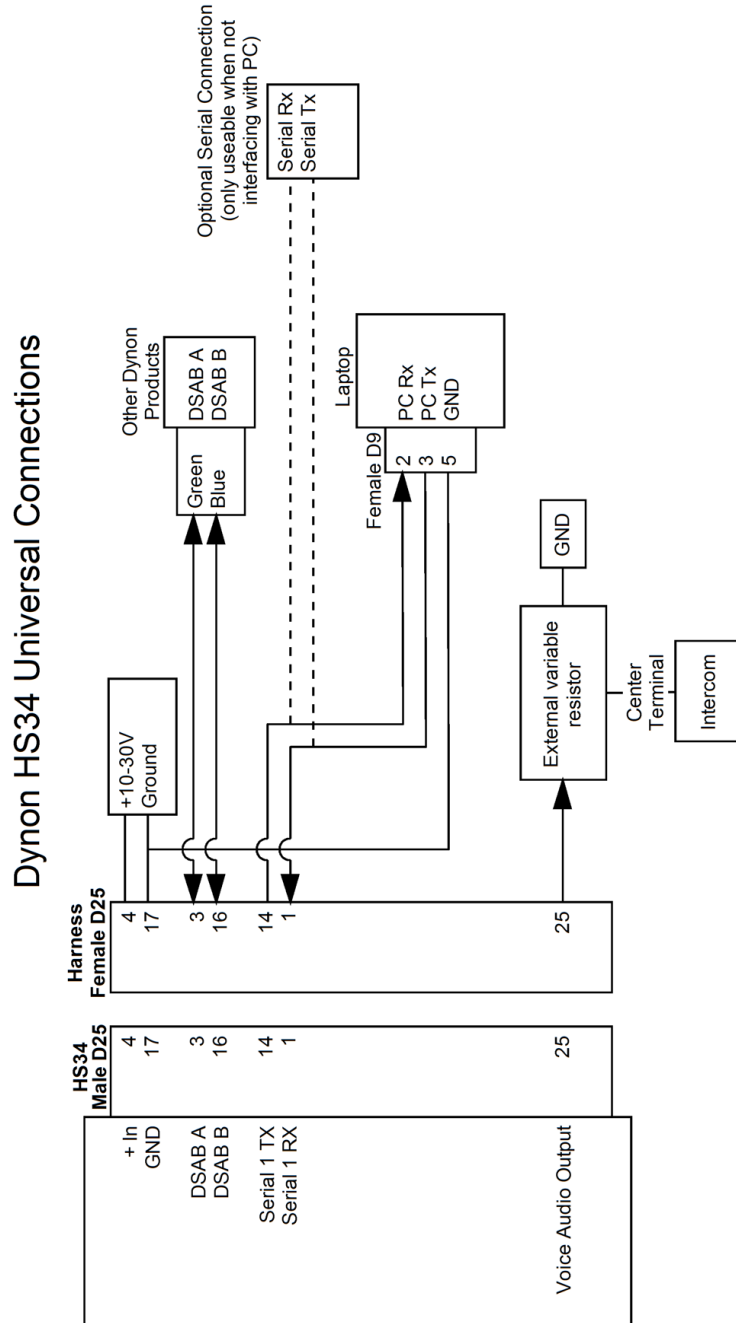

Generic Device Connections

The three diagrams on this page depict generic device connections for devices outputting ARINC, serial, or analog data. If your device outputs multiple types of data, connect only one type to the HS34 in the following preference: ARINC preferred over serial; serial preferred over analog. ARINC data streams contain more information (vertical GPS guidance, GPS steering, etc) than serial streams and allow more control of your external device. Likewise, serial streams contain more information than that carried over analog lines. If your device is one of those listed in the next section, Common Device Connections, you may ignore this section. See page 3-4 for a chart of supported GPSs.

Dynon HS34 ARINC Connections

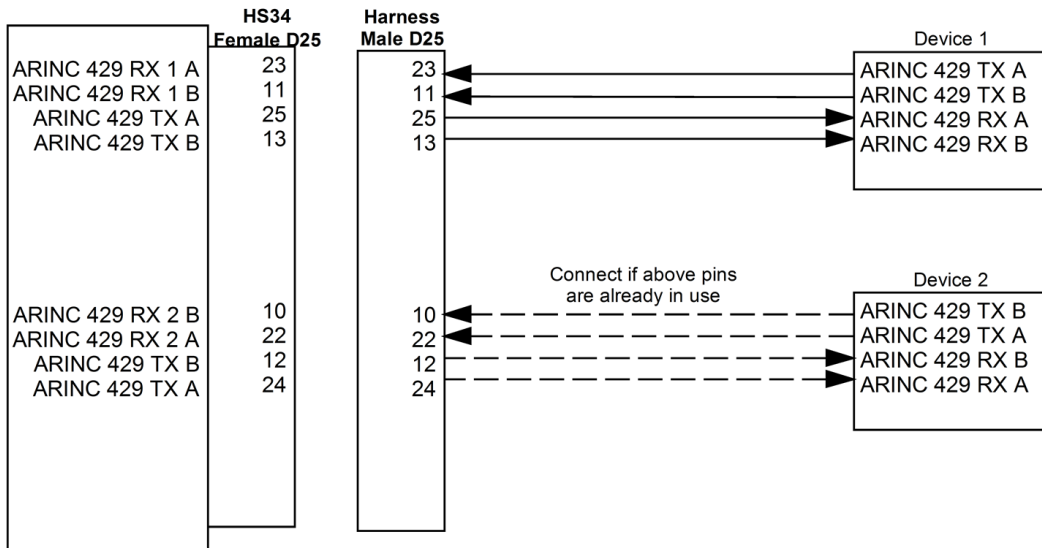

Dynon HS34 Serial Connections

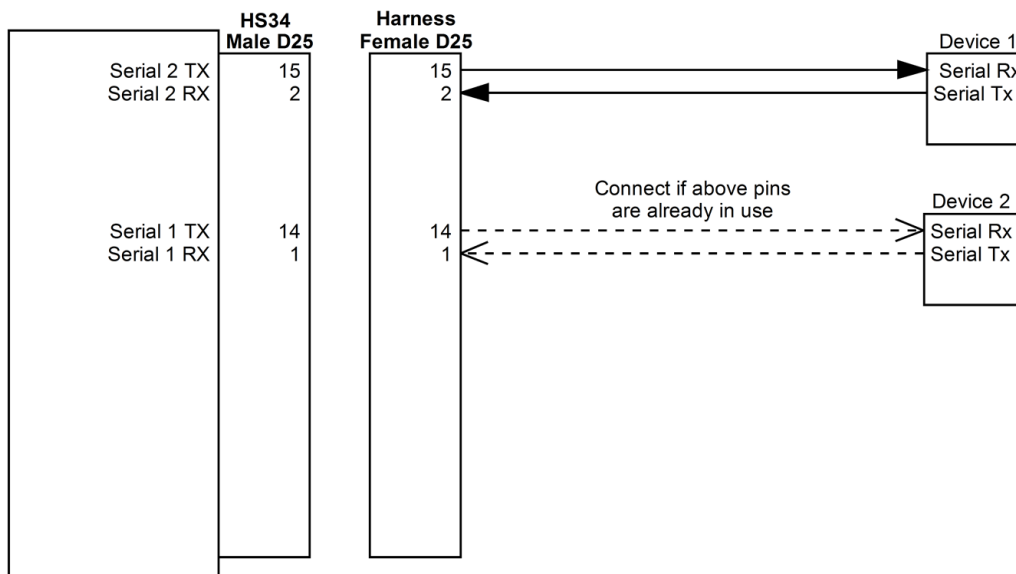



Dynon HS34 Analog Connections

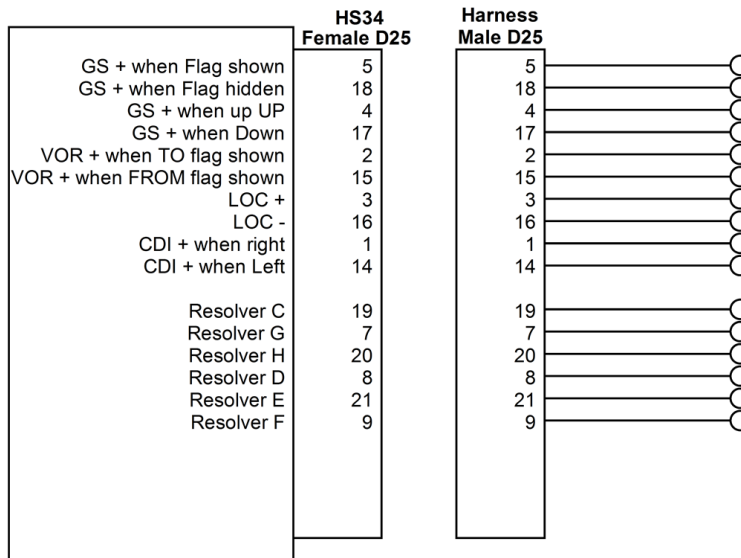

Common Device Connections

The following several diagrams show some common radios and GPSs, and the preferred connection schemes between them and the HS34. Make note of whether the connections are to the male or female connector on the back of the HS34. When constructing your harness, refer to the pinouts on page 7-11.

Dynon HS34 to Garmin 430/530

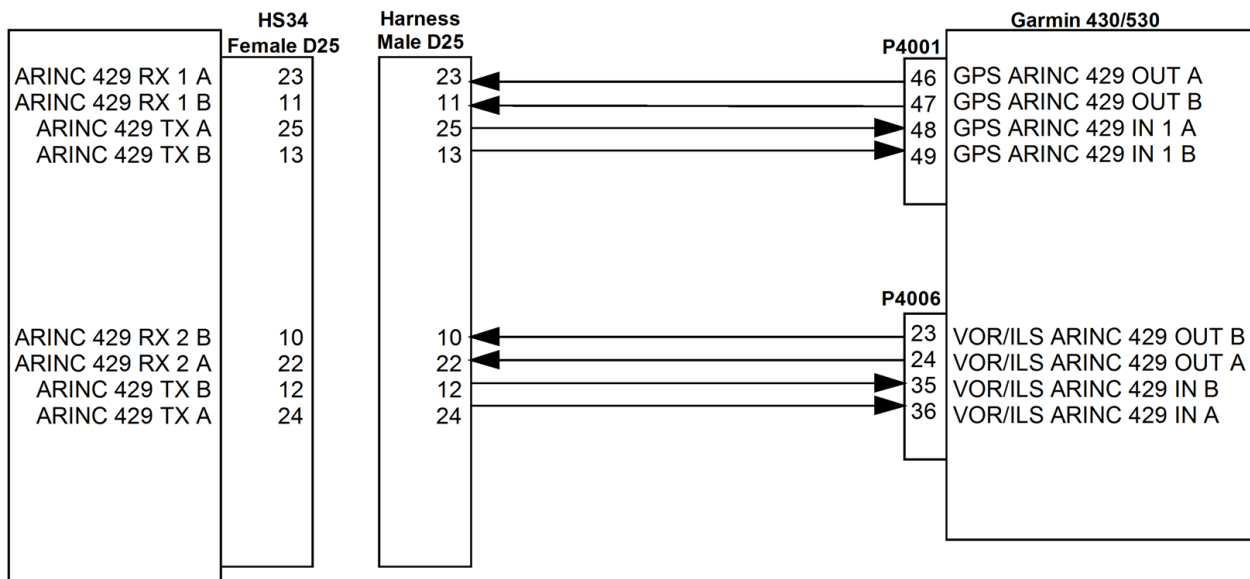

Dynon HS34 to Garmin SL30

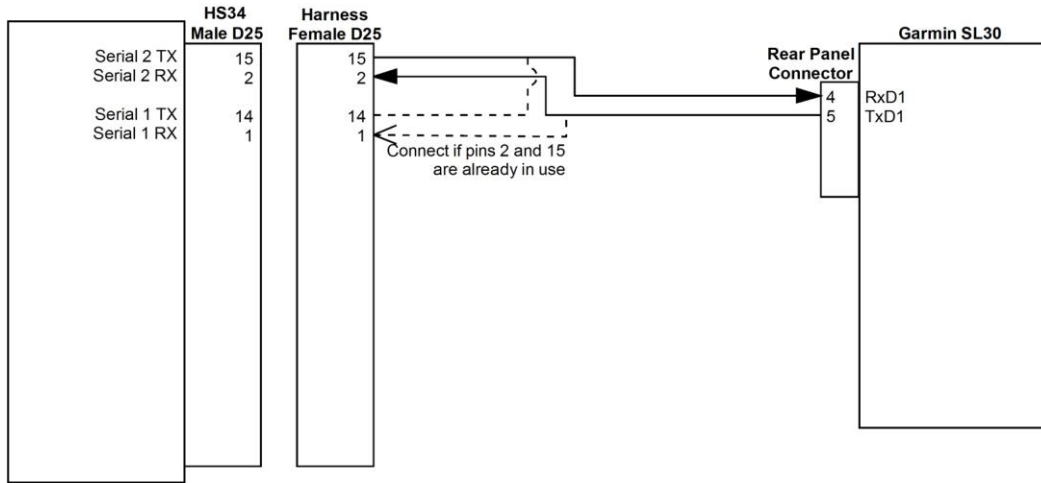

Dynon HS34 to Garmin GNC250/300 Series

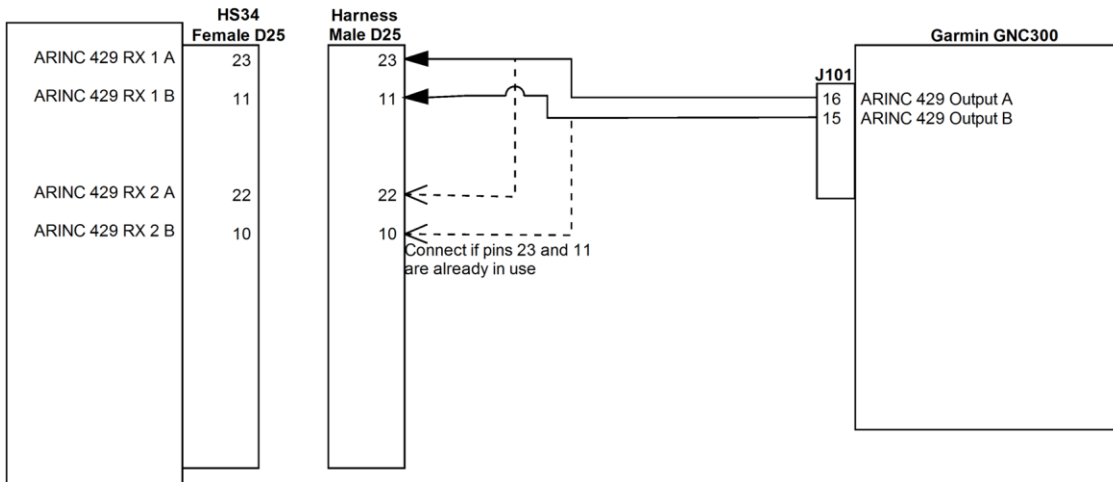

Dynon HS34 to Garmin 480

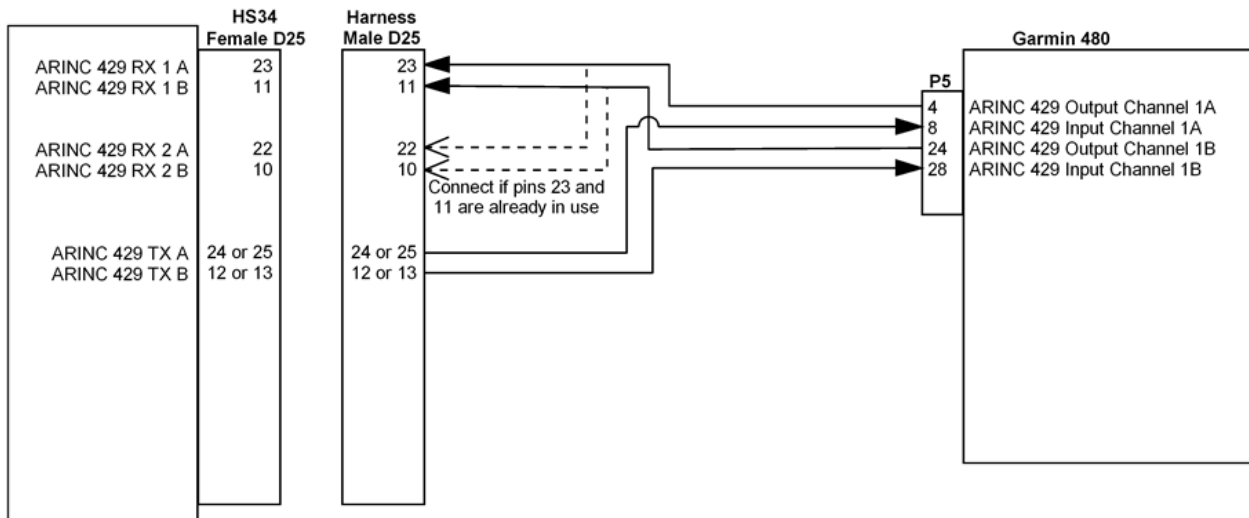



Dynon HS34 to Garmin X96

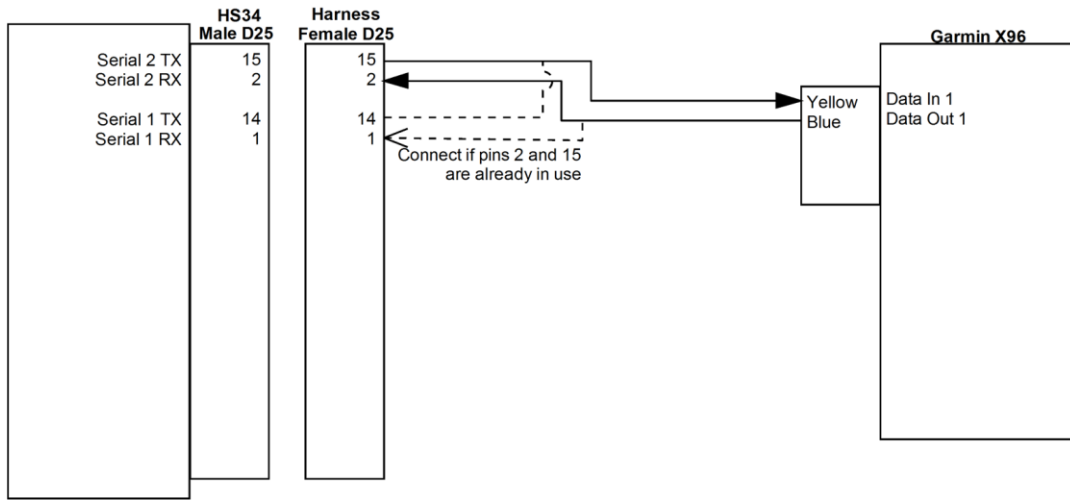

PANEL LOCATION AND MOUNTING

This section provides you with dimensions, panel location, and mounting information.

HS34 Dimensions and Panel Location

The diagram below shows the HS34's outer dimensions. Note that the instrument extends about 3.7" behind the panel, and that harnesses can require up to three more inches. Use the dimensions (in inches) found on the diagram to plan for the space required by the instrument. The front bezel of the vertically oriented HS34 (100755-000) is the same height as Dynon's D100-series products and can be mounted close to – or abutted against – one if desired. Plan a panel location that allows for convenient operation of the knobs and buttons. Ensure that the instrument is in a location where the light sensor (small circle of rubber at upper left of instrument) can measure the true ambient light conditions in the cabin.

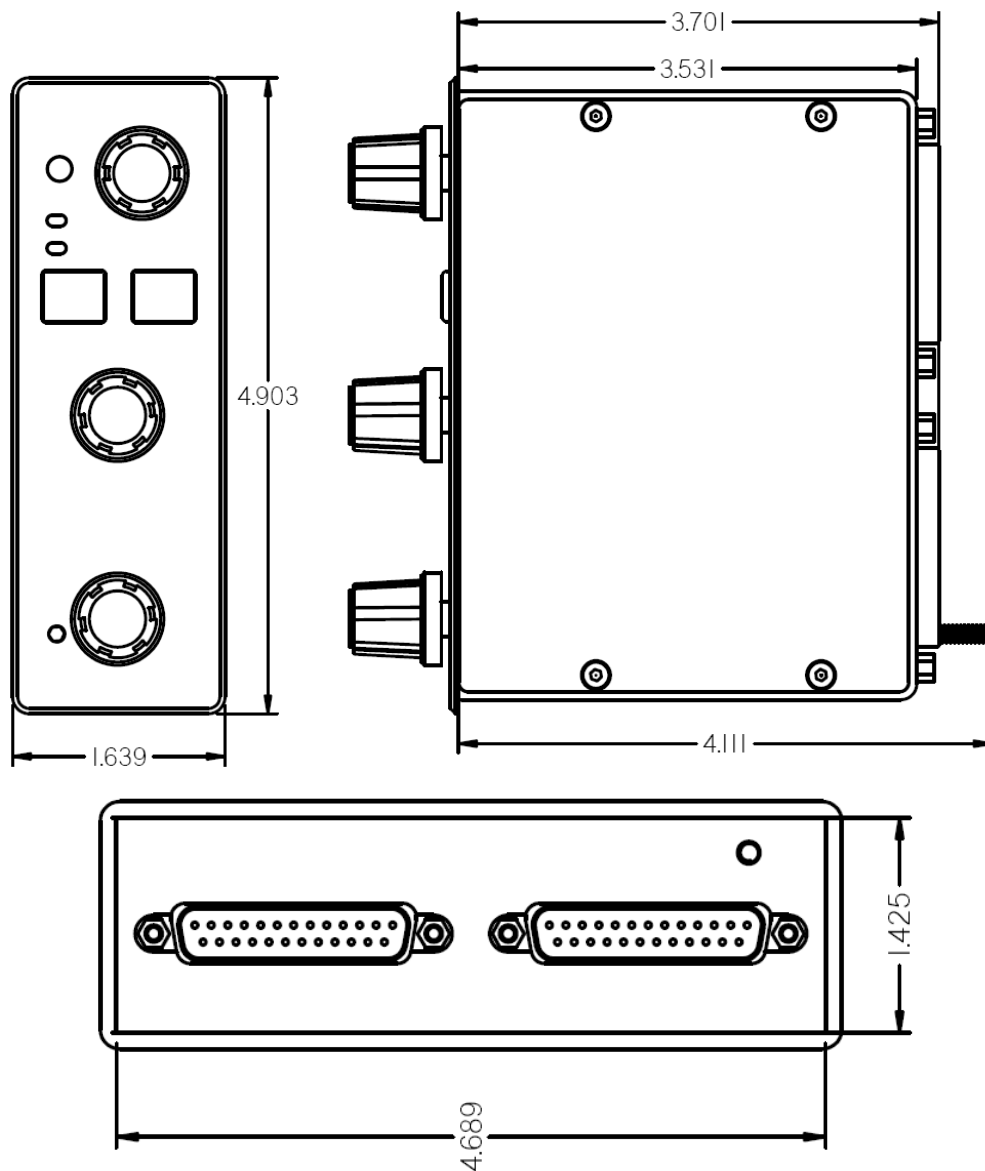



Mounting Tab Dimensions

The dimensions for the included mounting tab are below. Note that the tab does not extend behind the panel perpendicularly. This sharper angle causes the HS34 to pull itself against the panel when screwed into the tab.

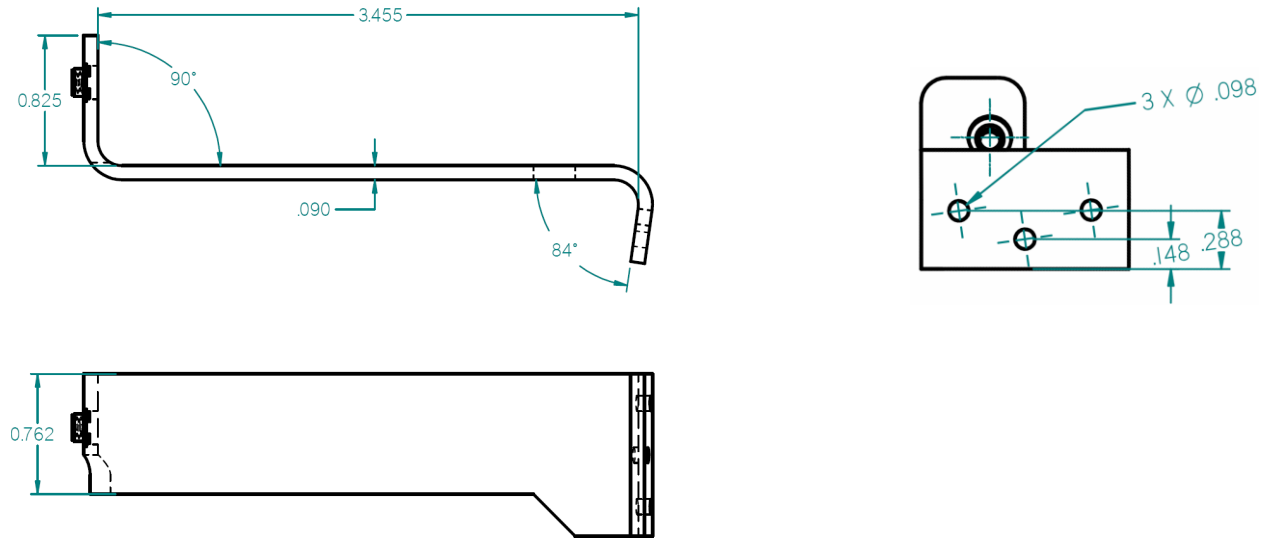

HS34 Mounting

As shown in diagram at right, make a rectangular cutout – oriented either vertically or horizontally, depending on HS34 version ordered – of 1.45” by 4.75” (3.69 cm by 12.07 cm). Drill three holes at the locations specified in the diagram. Your HS34 also shipped with a life-sized mounting template for making this cutout and drilling the mounting tab holes. Secure the mounting tab to your panel in whatever way you desire. Riveting it to the panel is ideal, but drilling holes for mounting screws and nuts also works.

Upon securing the mounting tab to the back of your panel, slide the HS34 into it. Because the mounting tab does *not* extend behind the panel perpendicularly, the HS34 must slide into the panel such that only the top (or right, for the horizontal version) of the bezel meets the panel. The tapered mounting screw fits into the PEM nut at the end of the mounting tab. Use the included 7/64” Allen wrench to secure the mounting screw into the mounting tab. As you screw the mounting screw tighter, the bottom (or left, for the horizontal version) of the bezel moves closer to the panel. Once it touches the panel, do not turn the mounting screw any further.

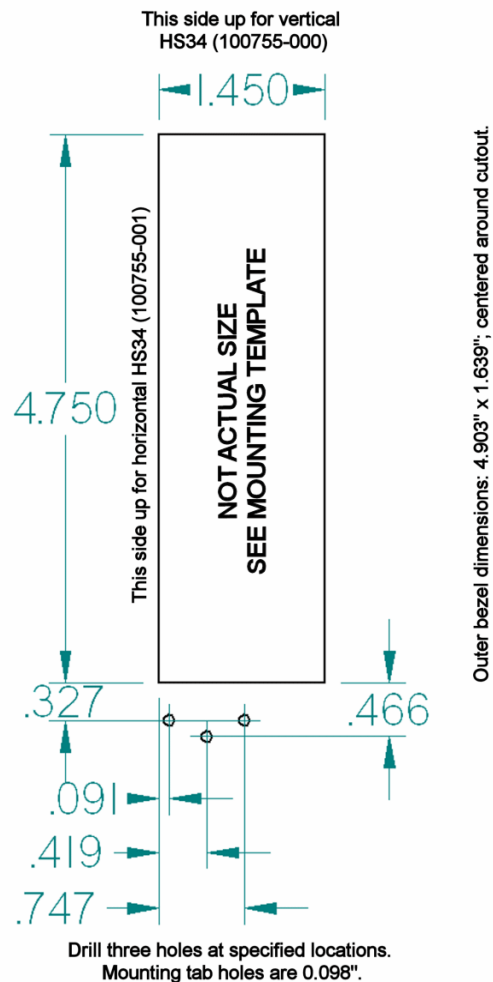

HS34 CONFIGURATION

This section guides you through configuring your HS34. Prior to beginning this section, you must have completed all the steps in the DSAB Configuration chapter with the HS34 turned on and connected to the DSAB network. After DSAB configuration, ensure that the HS34 appears as one of the ACTIVE devices in the EFIS > SETUP > DSAB > STATUS menu.

You may only configure your HS34 on the EFIS-based instrument assigned the DSAB Bus Master role. The following configuration steps are performed within the EFIS > SETUP > HSI menu on the Bus Master instrument.

Device Communication Setup

If you have connected a NAV radio to the **analog** pins shown in the Analog Connections diagram on page 7-13, enter the ANALOG menu to configure communication with this device. Press SEL ► to change the INPUT ENABLED to Y. The SYNCH OFFSET parameter is used to correct analog errors that can occur in the signal path between your radio and the HS34's measurement. You may normally leave SYNCH OFFSET set to 0. However, if you observe errors in the green course pointer on the HSI Page, you – or a qualified avionics shop – may modify this parameter to bring the course pointer into agreement with the NAV radio. Set SYNCH OFFSET, in degrees, to a value equal to the number of degrees of error in the course pointer on the HSI Page.

If you have connected one or two devices outputting **serial data**, push DOWN ▼ to select the SERIAL menu, and SEL ► to enter it. If the device connected to the SERIAL 1 RX and TX pins is a GPS, set INPUT to either AVIATION or NMEA (depending on the output format configured on your GPS), and OUTPUT to NONE. If the device connected to the serial pins is a Garmin SL30 Nav/Comm, set INPUT to SL30 and OUTPUT to SL30 CMD.

Set the BAUD RATE parameter to match the baud rate used by your SL30 or GPS. Many devices support more than one type of data format and baud rate; ensure that the INPUT and BAUD RATE settings for SERIAL 1 agree with the settings in the communication setup for the device connected to the HS34's Serial 1 pins. If you have a second NAV radio or GPS connected to the Serial 2 pins, repeat the above steps for it.

If you have connected one or two devices outputting **ARINC-429** data, push DOWN ▼ to select the ARINC-429 menu, and SEL ► to enter it. Set INPUT1 to the type of device connected to the HS34's ARINC-429 RX 1 A and B inputs: GAMA GPS, GAMA NAV, or DME. If you have connected a device to ARINC-429 RX 2 A and B, repeat the above configuration for the INPUT2 parameter; otherwise, leave it set to NONE. Next set the SPEED parameter (HIGH or LOW), based on the output speed of your two ARINC devices. The HS34 has one ARINC output channel with 2 sets of pins on the connector for wiring convenience. If one or both of your ARINC devices can accept commands, set the OUTPUT DATA to ON and configure OUTPUT SPEED appropriately.

Note that the EFIS/EMS SERIAL menu is disabled on all products connected to a DSAB system with an HS34 connected. All GPS and NAV devices must be connected to the HS34.

Markers Configuration

The HS34 supports markers input via ARINC or the 3 discrete Inner, Middle, and Outer marker pins.

If your NAV radio outputs ARINC data whose stream contains marker information, set the SOURCE to either ARINC1 or ARINC2. ARINC1 corresponds to the ARINC-429 RX 1 A and B inputs (female DB25, pins 11 and 23). ARINC2 corresponds to the ARINC-429 RX 2 A and B inputs (female DB25, pins 10 and 22). You must also ensure that the corresponding INPUT1 or INPUT2 parameter in the ARINC-429 menu is set to GAMA NAV.

If you have a device which outputs marker data via 3 discrete signals, set the SOURCE to MRKR PINS. Ensure that your device's Outer, Middle, and Inner outputs are connected to the HS34's male DB25 pins 22, 23, and 24, respectively. Marker beacon receivers use a variety of techniques to output the 3 marker signals. Because of this, you may need to experiment with the PULL-UP and ACTIVE WHEN parameters. As a general rule of thumb, if the schematic for your receiver shows the 3 discrete outputs connected to lights whose other side is connected to power, set PULL-UP to Y and ACTIVE WHEN to LOW. Likewise, if the schematic shows the 3 discrete outputs connected to lights whose other side is connected to ground, set PULL-UP to N and ACTIVE WHEN to HIGH.

Regardless the input type used, you can configure the HS34 to output tones for Outer (Morse code "dashes"), Middle (Morse code "dot-dashes"), and Inner (Morse code "dots") markers. Set TONES ACTIVE to Y to configure the HS34 to output the tones for each of the 3 markers. Set it to N to configure the HS34 to have no audible marker feedback.

DME Configuration

The HS34 supports Distance Measuring Equipment receiver input via ARINC or the single DME Analog In pin (female DB25, pin 6).

If you have connected a DME receiver which outputs ARINC data, set the SOURCE to either ARINC1 or ARINC2. ARINC1 corresponds to the ARINC-429 RX 1 A and B inputs (female DB25, pins 11 and 23). ARINC2 corresponds to the ARINC-429 RX 2 A and B inputs (female DB25, pins 10 and 22). You must also ensure that the corresponding INPUT1 or INPUT2 parameter in the ARINC-429 menu is set to DME.

If you have connected a DME receiver to the HS34's DME Analog In pin, set the SOURCE to DME PIN.

GPS and NAV Display Order Configuration

Pressing the NAV SRC button on the HS34 cycles through the available NAV sources in the following order: DG, NAV1, NAV2, etc., GPS1, GPS2, etc. Of course, the numbers of NAVs and GPSs in the cycle depend on how many of each type are configured in the ANALOG, SERIAL, and ARINC-429 menus.

If you have configured more than one input to receive NAV radio data, enter the NAV ORDER menu to see the list of configured NAV radios and the HS34 inputs they are connected to. In this menu, you may change the order that each NAV input occurs within the NAV portion of cycle. If you do not see all expected NAV radios, verify that all settings are accurate in the ANALOG, SERIAL, and ARINC-429 menus. Press DOWN ▼ or UP ▲ to select the input that you wish to

occur first in the NAV portion. Press MV UP ▲ until it appears next to NAV1:. Repeat this for the input you wish to be assigned NAV2 in the source cycle, and so on for as many other NAV radio inputs.

Repeat the above procedure for all configured GPS inputs in the GPS ORDER menu.

Voice/Tone Alert Configuration

The HS34 can act as the sole audio alert source for all DSAB-connected Dynon instruments. The HS34's audio output reports both EFIS and EMS alerts; each type of alert can be configured to be either voice or tone formats. When the HS34 is connected to your system, audible alerts are still generated by both EMS- and EFIS-based instruments. If you would like the HS34's audio out to be your only source for Dynon product audible alerts, disconnect the audio out connections on your other DSAB-connected Dynon products.

To configure HS34 audio alerts, enter the EFIS > SETUP > HSI menu, scroll down to AUDIO ALERTS, and press SEL ►. The following points describe the options available for each setting:

EMS: EXT TONE / EXT VOICE – Sets whether you want the HS34 to report tones or voice alerts during EMS alarm conditions. This setting has no effect on the “direct” audio output of the EMS.

EFIS: EXT TONE / EXT VOICE – Sets whether you want the HS34 to report tones or voice alerts during EMS alarm conditions. The “direct” audio output of the EFIS is muted*.

EFIS: EFIS TONE – tones are generated through the “direct” audio output of the EFIS and the audio output of the HS34 is muted.

AOA: EXT TONE – During an AOA alarm condition, tones are generated through the HS34 audio output and the EFIS “direct” audio output is muted*.

AOA: EXT VOICE – During an AOA alarm condition, voice is generated through the HS34 audio output simultaneously with a “progressive” tone from the EFIS “direct” audio output.

AOA: EFIS TONE – Tones are generated through the “direct” audio output of the EFIS and the audio output of the HS34 is muted.

EMS AUDIO ALERTS
RPM HIGH
MANIFOLD PRESSURE HIGH
OIL PRESSURE HIGH/LOW
OIL TEMPERATURE HIGH/LOW
EGT [1..6] HIGH/LOW
EGT SPAN
CHT [1..6] HIGH/LOW
CHT SPAN
CHT [1..6] SHOCK
FUEL LEVEL [1..4] LOW
FUEL PRESSURE HIGH/LOW
FUEL FLOW HIGH
VOLTAGE HIGH/LOW
CURRENT HIGH/LOW
COOLANT TEMPERATURE HIGH
COOLANT PRESSURE HIGH/LOW
<i>All other EMS alerts vocalized “EMS ALERT”</i>
EFIS AUDIO ALERTS
ALTITUDE (Altitude alerter)
CLIMB/DESCEND (Altitude alerter)
AUTOPILOT DISCONNECT
STALL
TIMER EXPIRED
DSAB ERROR

* If an HS34 failure is detected during this condition, the EFIS “direct” audio output (tones only) is automatically re-enabled (fail-over).

Selecting TEST VOICE OUTPUT and then pressing SEL ► produces an audible voice test (“DYNON AVIONICS”) on the audio output line. This allows you to verify connections and volume on the ground.

The possible voice alerts for both EFIS and EMS are listed in the table above.

VALUE Knob Configuration

The VALUE knob changes the ALT and BARO settings and is configured from HSI SETUP > VALUE KNOB ►.

The VALUE knob can be configured to require an initial push before rotating the knob has any effect (REQUIRE PUSH: YES / NO).

The “default” mode of the VALUE knob is configured by setting FIRST ACTION: ALT / BARO to set Altimeter or Barometer mode, respectively.

If REQUIRE PUSH is set to YES:

- The first push of the VALUE knob activates the FIRST ACTION mode (ALT or BARO) and displays a “pop-up” window indicating the current mode and value. Rotating the knob within 5 seconds changes the value of the FIRST ACTION mode (ALT or BARO). A second push of the VALUE knob within 5 seconds after rotating the knob de-activates the VALUE knob and closes the pop-up window. If there is no further action (either a knob push or knob rotation), the VALUE knob automatically de-activates (times out) after 5 seconds and closes the pop-up window.
- If, after the first push of the VALUE knob, the knob is *not* rotated, a second push of the VALUE knob within 5 seconds activates the secondary mode of the VALUE knob – indicated by the mode displayed in the pop-up window.
- Pushing the VALUE knob a third time or after a knob rotation (within the 5 second windows described above) de-activates the VALUE knob and closes the pop-up window.

If REQUIRE PUSH is set to NO:

- Rotating the VALUE knob changes the value of the FIRST ACTION mode (ALT or BARO) and displays a pop-up window indicating the current mode and value. Pushing the VALUE knob again within 5 seconds of the last knob rotation closes the pop-up window.
- Pushing the VALUE knob without first rotating it activates the secondary mode of the VALUE knob (ALT or BARO, whichever was not chosen as FIRST ACTION) and displays a pop-up window indicating the current mode and value. Pushing the VALUE knob again within 5 seconds of the last knob rotation closes the pop-up window.
- If there is no further action (either a knob push or knob rotation) within 5 seconds, the pop-up window automatically closes.

NAV and/or GPS Fail-over

While not required, it is possible to provide a NAV and/or GPS data fail-over capability in case of a failure of the HS34. To accomplish this, the outputs of the NAV and/or GPS device can be connected in parallel to an EFIS or EMS *and* an HS34. While the HS34 is operating normally, the NAV and/or GPS data connected to the HS34 is displayed. (Only) if the HS34 fails, the NAV and/or GPS data connected to the EFIS and/or EMS is (temporarily) displayed. There is no indication provided that the data being displayed is connected to the EFIS and/or EMS – only a notification that the HS34 has failed.

To configure and test NAV and/or GPS failover:

1. Temporarily disconnect or power off the HS34 and reconfigure the system without the HS34.
2. Connect and configure the NAV and/or GPS outputs to the EFIS and/or EMS inputs. Ensure that the NAV and/or GPS data is being properly displayed on the EFIS.
3. Reconnect the HS34 and reconfigure the system to recognize the HS34.
4. Connect and configure the (parallel) NAV and/or GPS outputs to the HS34. Ensure that the NAV and/or GPS data is being properly displayed on the EFIS.
5. To test the fail-over capability, temporarily disconnect the HS34 and observe the NAV and/or GPS data on the EFIS; data should display properly after a pause of a few seconds with the HS34 connected, and disconnected.

Appendix D: Dynon AOA/Pitot Installation and Calibration

Thank you for your purchase of Dynon's AOA/Pitot Probe. This guide walks you through the steps to install and calibrate both the heated and unheated versions of the AOA/Pitot Probe. While the probe senses standard pitot pressure, allowing it to work with any standard airspeed indicator, its AOA functionality is designed specifically to work with Dynon's EFIS series of products. Do not expect it to work properly with another AOA system.

To ensure accuracy, it is very important that you install the probe correctly and perform the specified calibration steps. We recommend that you read the entire guide before proceeding with the installation.

Dynon's Heated AOA/Pitot Probe is nickel-plated. Do not polish the probe as this will cause the finish to come off.

AOA CALCULATION: PRINCIPLES OF OPERATION

Dynon Avionics' AOA/Pitot probe performs two functions: airspeed sensing and angle of attack sensing. These functions require two pressure ports on the tip of the probe. The normal pitot pressure port is on the front face of the probe and is designed to be insensitive to angle of attack. The second pressure port is located on an angled surface just under the pitot port and is designed to be very sensitive to AOA. The EFIS-D100 then uses the difference between these two pressures to calculate the current angle of attack.

HEATING: PRINCIPLES OF OPERATION

The heated version of Dynon's AOA/Pitot Probe utilizes a heating mechanism unlike any other heated pitot on the market. The probe is heated by a high-quality nichrome heating element whose temperature is accurately measured and regulated by the heater controller. This controller – located in an enclosure which can be mounted in a wing or elsewhere – regulates the heat at the tip of the probe to a constant temperature. There are several advantages to this, including: lower power consumption, increased heating element lifespan, and a much cooler pitot on the ground when de-icing is not necessary. This unique technique ensures that the pitot can be rapidly de-iced when required, but does not needlessly waste electricity when not in icing conditions.

While the probe does not operate like a normal heated pitot, it will still get fairly hot in normal ambient temperatures. When turned on, it will regulate its internal temperature to about 70°C to 80°C. To ensure that the heater is working, briefly touch the end of the pitot farthest from the snout after 1 minute of operation and verify that it is warm.

FAILURE WARNING

Designed to meet the indication requirements of FAR 23.1326, the heated pitot controller has an output that can trigger a warning light in the cockpit whenever the probe heater is turned off or is not functioning properly. While not required for Experimental and LSA category aircraft, this feature provides peace of mind, giving you instant feedback that your probe's heater is working as designed.

TOOLS AND MATERIALS REQUIRED

- Dynon Avionics AOA/Pitot probe.
- Two plumbing lines (usually ¼” soft aluminum or plastic tubing) routed from the EFIS-D100 to the probe mounting location.
- Tubing interface hardware
 - Reference our wiki at wiki.dynonavionics.com for tubing interface hardware recommendations.
- #36 Drill and 6-32 tap
- AOA Pitot Mounting bracket. Models known to work well include:
 - Gretz Aero CBK12 (Chrome) and PBK12 (Paintable), available at gretzaero.com/mountbracket.html or from Aircraft Spruce.
 - SafeAir1 also makes a bracket with a joggled lip for the RV series. It is available from www.safeair1.com.

Please follow these instructions explicitly as improper installation can result in permanent damage to your device and/or aircraft.

HEATER CONTROLLER WIRING AND MOUNTING

If you have purchased the heated version of the probe, please follow the instructions in this section. If you have purchased the unheated version of the probe, you may skip to the AOA/Pitot Probe Mounting section on page 7-28. Please follow these instructions explicitly as improper installation can result in permanent damage to your device and/or aircraft.

Heater Controller Mounting

The heater controller box should *ideally* be mounted close to the AOA/Pitot Probe. The box’s dimensions are found at right, for reference. When mounting the controller close to the probe, ensure that it is close enough for its wires to mate with the probe’s wires, with room for strain-relief. If you find it difficult to mount the controller in the wing, or simply wish for the controller to be mounted closer to the battery, you must extend the lines using the correct wire gauge as described in the Wiring section below.

When the desired location is selected, secure the heater controller via the 4 mounting holes. Route the wiring between the probe, controller, panel, and power source, as described below.

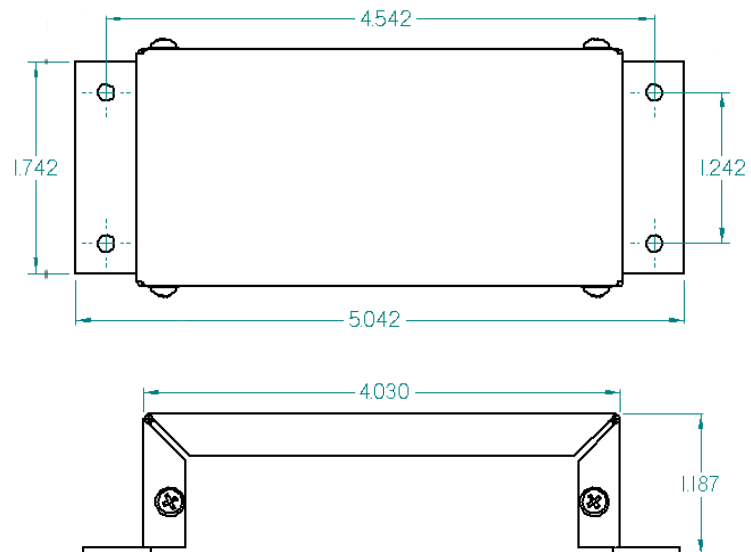



Heated AOA/Pitot Wiring System Overview

The following block diagram depicts the basic layout of the electrical connections between the probe and heater controller. This diagram should be used in conjunction with detailed instructions on the following pages. Read the specific instructions for each connection prior to installation.

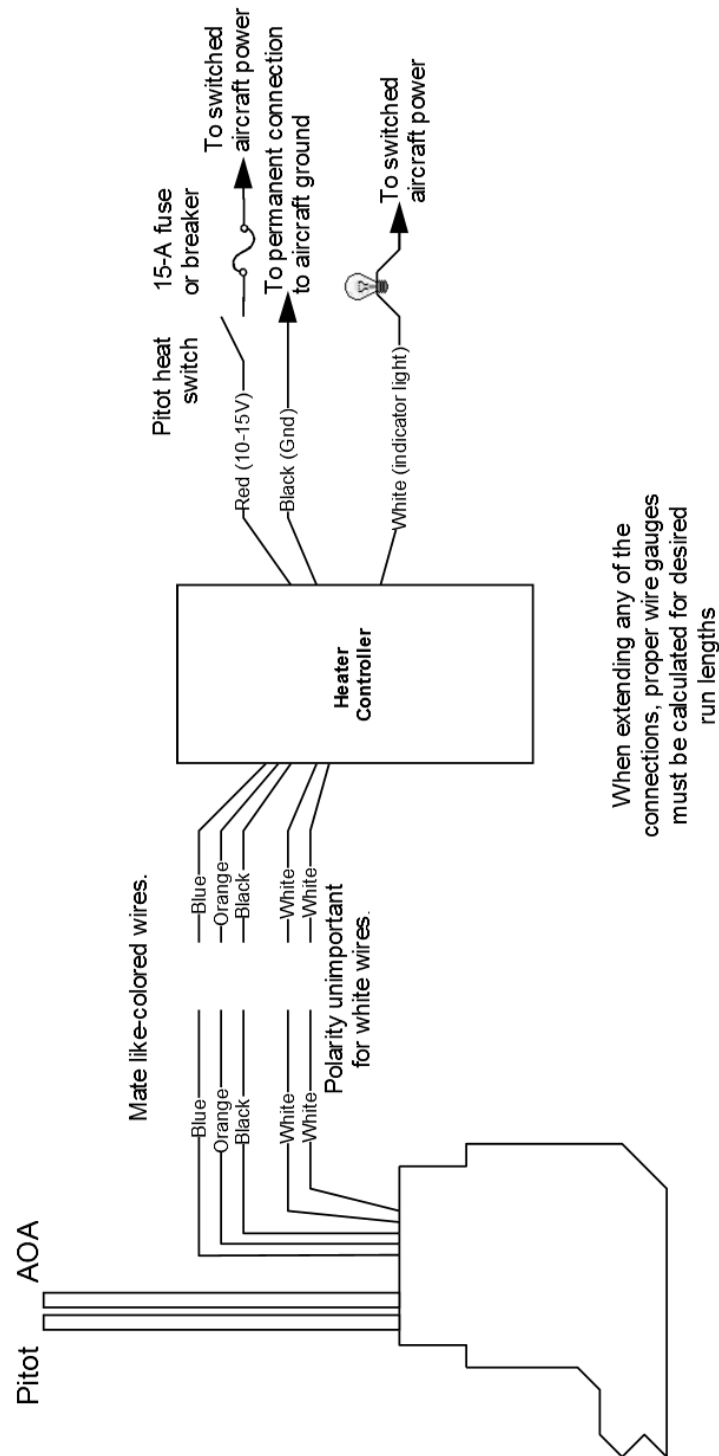

Heater Controller Wiring

Before making the connections to your Heated AOA/Pitot Probe and controller, refer to the Recommended Wiring Practices section on page 2-1. The chart at right provides general recommendations for wire gauge choice, given wiring run length.

Probe to Controller Wiring

As mentioned above, it is preferable that the heater controller box be mounted near enough to the probe that 5 wires between the controller and probe can be connected without extension. The three mating pairs of colored wires – terminated with Fastons – are used to carry the current to the heating element in the probe. The 2 white wires are for temperature measurement, and can thus be small. If you have mounted the heater controller near the probe and do not need to extend the wires between the two, simply plug each wire on the controller into its corresponding like-colored wire from the probe.

If you do need to extend the wires between the probe and the controller, use the recommended wire size (see chart on page 7-25) for your run length. Since extending the wire runs requires that you cut the connectors off the 5 wires between the probe and controller, splice the extension wires between the probe and controller using butt splices or other similarly secure method. The white wires are not polarity-dependant. Additionally, as the white wires do not carry any significant current, you may extend them with 26 AWG or larger for any run length.

Controller Power wiring

Three wires – colored red, black, and white – exit the controller for connection to your electrical system. Power (between 10 and 15 volts) is fed to the controller via the red and black wires. The maximum current draw of the heated pitot controller/probe is 10 amps. You must route your own appropriately-sized wires to where the heater controller is mounted. Both power and ground lines should be able to handle 10 amps with minimal voltage drop, as recommended in the chart on page 7-25.

The red wire should be connected through a pilot-accessible switch to the main power source in the aircraft (limited to 15 volts). The switch allows you to manually turn the heater controller on and off, depending on the situation. Install a 15-amp fuse at any point along the power line to the heater

Recommended wire gauge for runs, given 10-amp peak current	
Run length	Gauge
0' – 7'	18 AWG
7' – 9'	16 AWG
10' – 16'	14 AWG
17' – 24'	12 AWG
25' – 40'	10 AWG

From FAA AC 43.13-1B, page 11-30

Color	Notes
Red	Connected through a pilot-accessible switch to 10–15V supply. Must handle up to 10 amps.
Black	Must have a constant connection to ground. This is required for the warning light to operate when controller is powered off or not functioning. Line must handle up to 10 amps.
White	Connected to a light bulb (or resistor & LED) tied to switched ship's power. This line is grounded when the heater controller is powered off or not functioning. Connection can handle no more than 1 amp. Current depends on light source connected.

controller. Remember that even when the controller is powered on, it only heats the probe the amount necessary to maintain temperature.

The black wire should be permanently connected to ground. Cutting power to the heater controller should occur via the red power line, not the black ground line.

Heater Status Connection

Note: The probe heater functions properly whether or not you make this connection. It is simply a status output for your convenience.

The white heater status wire is grounded when the probe heater is turned off or not functioning properly. This wire should be connected to a light on the panel, whose other terminal is connected to switched aircraft power. When the heater is on and functioning properly, the white heater status line is open, leaving the indicator light turned off. When there is no power to the heater controller – or it is not functioning properly – the white line is grounded, turning the indicator light on.

Aircraft Spruce P/N 17-410 is an example of a light that will work for this application. An LED and resistor in series will also suffice. If you use an LED as the indicator, you must choose a resistor that delivers the appropriate current to the LED, and can accommodate the power required for its current and voltage drop.

If you own a Dynon EMS-based product, you may also use one of its two contact input to display an onscreen indication. Connect this heater status output directly to the desired EMS contact input, with no additional resistors or lights. You must configure the contact display as described in your EMS-based product's Installation Guide.

AOA/PITOT PROBE MOUNTING

The Dynon Avionics AOA/Pitot probe has been designed as an under-wing pitot. The following information applies to this type of installation. If you wish to mount your pitot on nose boom mount, contact us so we can make the appropriate adjustments to your pitot. The heated version of Dynon's AOA/Pitot Probe does not come in a boom-mount configuration.

AOA/Pitot Probe Mount Location

The Dynon Avionics AOA/Pitot probe only functions correctly when mounted in a location where the airflow over the probe is relatively undisturbed by the aircraft. In general, we recommend that you mount it at least 6 inches below the wing and with the tip of the probe between 2 and 12 inches behind the leading edge of the wing. Typically, pitot probes are mounted about mid-wing span wise to minimize the effects of both the propeller and the wing tips. Testing during the probe development has shown that the standard mounting locations for the pitot probe in the RV series of aircraft also works for the Dynon probe.

AOA/Pitot Probe Mounting Instructions

After the mounting location has been determined, mount the pitot mounting kit per the included instructions or fabricate your own mount. In either case, mount the probe securely to the wing such that the body of the probe is horizontal during level flight. Drill and tap mounting holes (#6-32) on the probe to match your mounting bracket. Use caution when drilling the holes, ensuring that you avoid drilling into the pitot and AOA pressure lines. As long as you do not penetrate



these lines, you may drill all the way through the outer metal without affecting the probe's waterproofing.

DIMENSIONS

Standard mount

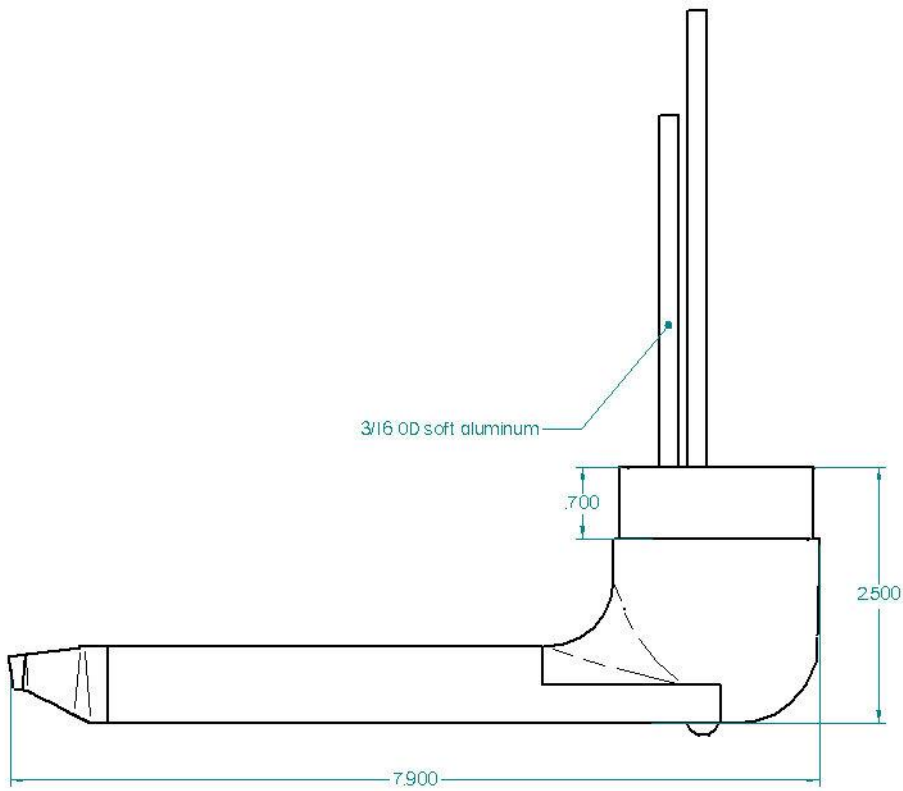
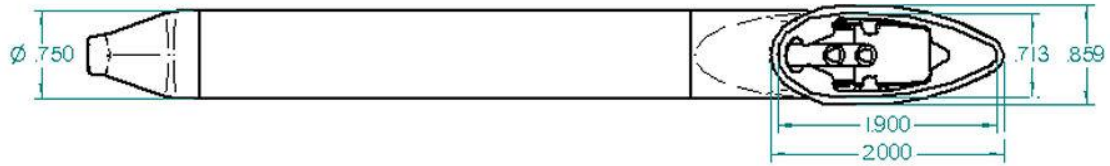

Boom mount

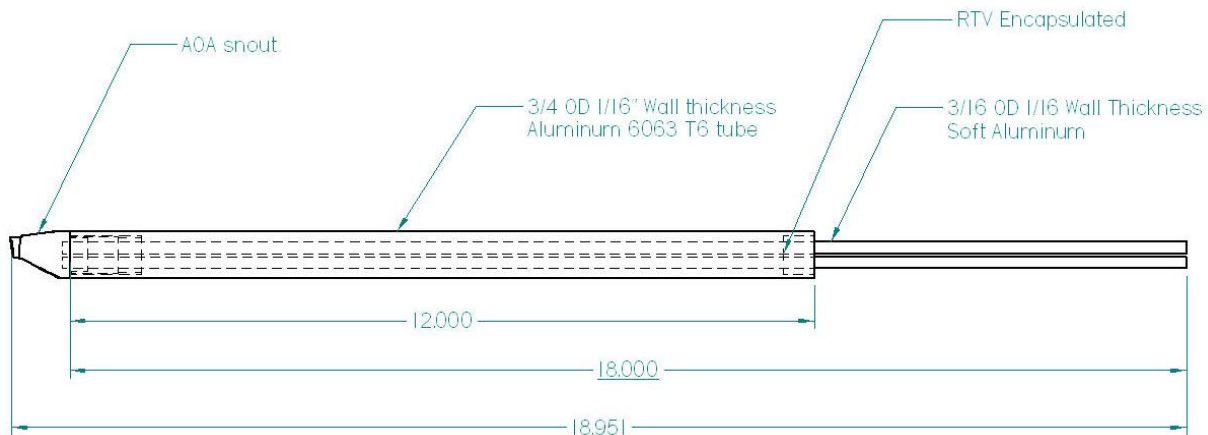

PLUMBING

NOTE: Because the pitot and AOA plumbing tubes have not been annealed, they work-harden rapidly when manipulated. Make gentle bends, and only bend any given section **once**.

After mounting the probe, route the pitot and AOA lines from the probe to your EFIS-D100. The tube closest to the snout is the pitot line, while the tube in the rear is the AOA line. There is no static source on the probe.

After mounting the probe, install adapters to connect the 3/16 plumbing lines from the probe to whatever plumbing lines run back to the EFIS-D100 in your aircraft (AN 919-2D for 3/16 to 1/4). We strongly recommend using aircraft grade fittings such as standard AN fittings. Make sure the plumbing lines do not chafe or interfere with any aircraft control systems.

PRESSURE CHECK

Dynon's pitot design deliberately has a pin-sized leak hole in each of the two tubes to permit draining any moisture which might accumulate inside. These holes are located in the middle of the tube at the bottom. Plugging these holes does *not* guarantee a pneumatic seal (although one is sometimes present). The leak that may exist does not affect the performance of the probe. You will, however, need to take it into account when doing pressure/leak tests on your pitot system

CALIBRATION

- ! **CAUTION:** It is your responsibility to fly your plane safely while performing any configuration or calibration in flight. The best scenario would include a second person to perform any necessary steps on the EFIS-D100.

Once you are flying straight and level at a safe altitude for stalls, enter the EFIS > SETUP > AOACAL menu. While the AOACAL menu is displayed, oscillate the aircraft between $\pm 5^\circ$ pitch 4 times at fast cruise airspeed. During this maneuver the EFIS-D100 records the lowest angle of attack that you usually see during flight. You do not need to push any additional buttons before starting this maneuver.

Refer to the list below of the stalls recommended to complete the user calibration. The general idea is to record stall data to find the lowest angle of attack stall. The list we have suggested is a starting point and produces a good calibration under most circumstances. However, if there are

flight regimes not listed that you suspect would create stalls at lower angle of attack it would be good to record those as well.

- With full power, no flaps
- With no power, no flaps
- With full power, full flaps
- With no power, full flaps

Push the STALL button before performing each stall. When you push the STALL button, a 45-second timer starts. Notice the “T” next to the time that is counting down. During the 45 seconds that the timer is counting down, you are expected to have completed the stall maneuver. If any stall maneuver is not completed before the timer expires, the calibration will be invalid, and should be reset. To do this, push the CANCEL button. This exits the AOACAL menu; re-enter it to begin the calibration again. **After completing the stall, make sure you let the 45 second timer count down to 0 before you push the STALL button for the next stall.**

When the listed stall maneuvers have been completed according to the above procedure, push FINISH. At this point, the AOA indicator has been calibrated. If it is not visible, turn the display on in the EFIS > SETUP > CLUTTR > AOABAR menu. This calibration should result in the lowest angle of attack stall occurring just above the red/yellow boundary. If this is not the case, please repeat the AOA user calibration, including flight configurations that resulted in stalls with incorrect indications. If the user calibration continues to be unsuccessful, please contact Dynon Avionics technical support.

ALARM SETUP

Enter the EFIS > SETUP > AOAALM menu and press any of the buttons beneath the AUDIO label to select the point on the AOA bar at which you wish the alarm to sound:

AUDIO: ALWAYS OFF
AUDIO: ON IN RED
AUDIO: START YLW TOP
AUDIO: START YLW MID
AUDIO: START YLW BTM

The latter three alarms (the ones that begin with START) are progressive, meaning the audio alert gets more intense as your angle of attack increases. You may set these progressive alarms to start at the top, middle, or bottom of the yellow section of the AOA bar. Setting AUDIO to ON IN RED configures an intense alarm to occur only when the AOA indicator is in the red.

To reduce nuisance audible AOA alarms – such as when taxiing, taking off and landing – the alarm can be inhibited below a selected airspeed. While in the EFIS > SETUP > AOAALM menu, press MINSPD to configure the minimum airspeed at which an AOA alarm can occur. Anytime airspeed is below the MINSPD value, AOA alarms will not occur; anytime it is above the MINSPD value, alarms can occur. If the AOA alarm is already sounding as airspeed falls below this threshold, it will continue to sound until the high AOA condition is resolved.

HS34 The optional HS34 offers the ability for the Audio alarms above to include tone, voice, or both tone and voice. For details on setting up tone/voice alarms, consult Voice/Tone Alert Configuration on page 7-21.

Appendix E: Encoder Serial-to-Gray Code Converter Installation

INTRODUCTION AND DESCRIPTION

The Encoder Converter is an electronic device that receives the serial encoder data from the EFIS-D100 and outputs standard Mode-C parallel Gray code into your Mode-C transponder. This Encoder Converter requires data from the EFIS-D100 and is not to be confused with other standalone encoders available on the market. While the installation is not complex, it is important that you install the unit correctly. The Encoder Converter does not output an encoder strobe signal.

The Encoder Converter is designed to be powered off voltages between 10 and 30 volts.

TOOLS AND EQUIPMENT

The following parts are not included with your Encoder Converter purchase but may be necessary to complete the installation.

- Wire cutters
- Connector crimp tool
- Crimp pins
- 25-pin EFIS harness to mate with EFIS-D100 (may have been purchased with your EFIS-D100)
- Connector to mate with Gray code transponder

ELECTRICAL INSTALLATION

The following section describes the wiring requirements for using the Encoder Converter. Please follow these instructions explicitly as improper wiring can result in permanent damage to your unit.

RECOMMENDED WIRING PRACTICES

NOTE: Use correct splicing techniques for all electrical connections, taking care to properly insulate any exposed wire. A short circuit between any of the wires may cause damage to the Encoder.

The wire used in construction of your Encoder Converter is 22 gauge avionics grade Tefzel wire, which meets Mil Standard MIL-W-22759/16.

Installing: Make sure all connections are secure and all wires are routed and strain relieved to ensure that the wires will not chafe against any other object in the aircraft.

STEP 1: TRANSPONDER WIRING

Wire the Encoder Converter signals to their respective connections on your Mode-C transponder. Mode-C transponder pin-outs vary from device to device. To find the correct pin-out, look at the manual for your transponder or contact its manufacturer. The table below details which color wire should be connected to each Transponder pin. All of the wires listed in the table leave one end of the Encoder Converter in a single bundle. If your transponder has a switched power

output, connect this to the power inputs on the Encoder Converter. If your transponder does not include this switched power output, the Encoder Converter power connections should be made directly to your switched avionics power. Ensure that all avionics power is off before performing the wiring step of this installation.

If your Altitude Transponder has either a strobe signal or a D4 pin, leave these pins unconnected.

Transponder Pin	Encoder Converter Wire Color
A1	Yellow
A2	Green
A4	White with Blue
B1	Blue
B2	Orange
B4	White with Red
C1	White with Green
C2	White
C4	White with Black
Power (10V-30V)	Red
Gnd	Black
Strobe Signal	No Connection

The Gray code output of the Encoder Converter reports altitude not adjusted for barometric pressure, as required by FAA specification. The altitude reported by the EFIS-D100 encoder will always match the altitude shown on screen when the BARO value is set to 29.92 inHg.

STEP 2: CONNECTING TO THE EFIS-D100

Before wiring connections to the EFIS-D100 check to ensure that the wire length between your Encoder Converter and your EFIS-D100 is appropriate. Add or remove wire length if needed or desired. Customizing the wire length will facilitate an installation that is both cleaner and more secure.

The only pins of interest on the EFIS-D100 connector for the Encoder Converter installation are pins 13 and 21. The two wires exiting the Encoder Converter are the EFIS-TX and the EFIS-Ground, which are green (or red) and black respectively, and 2 feet in length. Connect these wires to the EFIS-D100 25-pin female harness.

Ensure that your EFIS-D100 is powered off. Then connect the black EFIS Ground wire to pin 21. Then, connect the green wire to pin 13 (Serial Encoder Transmit) on the EFIS harness.



EFIS DB25 Pin#	Dynon EFIS harness color	Encoder Converter Wire Color	Function
13	Blue/White (may be black on some harnesses)	Green (May be Red on older models)	Serial Encoder Transmit
21	White	Black	Serial Encoder Ground

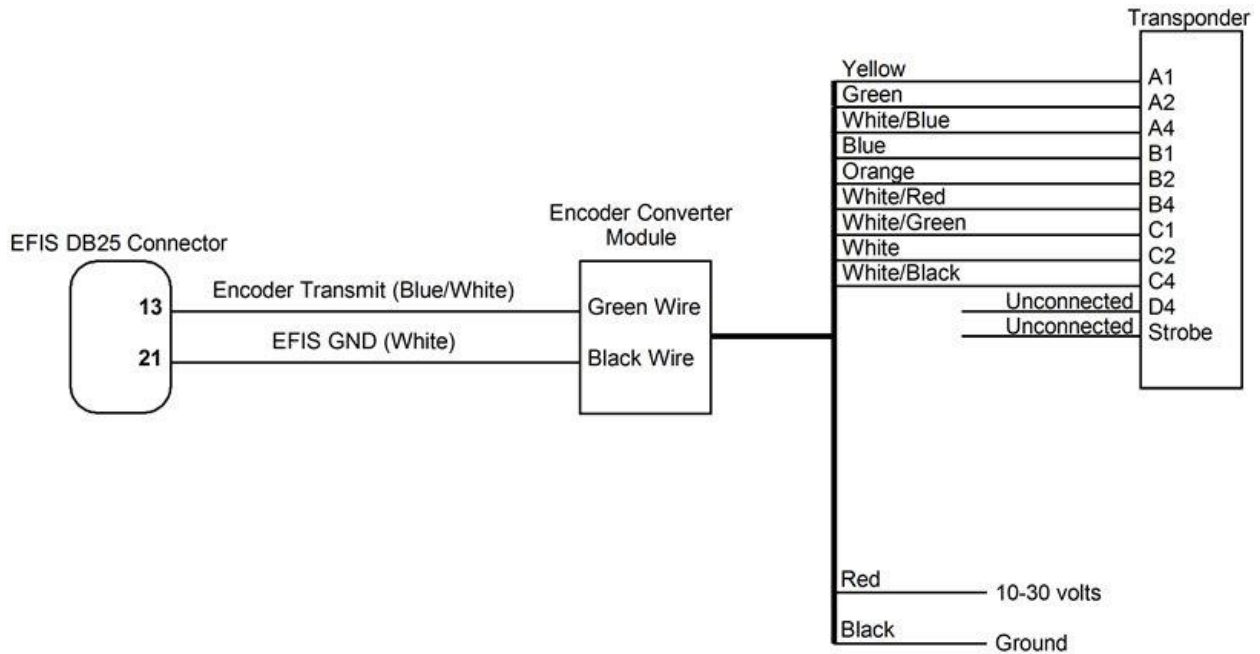

STEP 3: EFIS-D100 ENCODER FORMAT

For proper communication the EFIS Altitude Encoder format must be set to format number one. To change this setting, from the main menu, select: MORE > SETUP > MORE > ALTENC. Press FRMAT until it reads “1.”



Appendix F: Replacing the EFIS-D100 battery pack

1. Remove the two screws (either #1 Phillips or 7/64" hex, depending on when your unit was manufactured) from the small, rectangular battery door on the side of the EFIS-D100. Remove the battery door. Do not remove any other screws from the case of the unit.
2. If you previously had a battery, disconnect it from the EFIS-D100 by unplugging the battery connector and gently pulling out old battery. It is safe to *gently* pull on the battery wire to remove the battery.
3. Insert the new battery with the bumpy side up.
4. Connect the battery connector to the battery. The connector is keyed; make sure it is positioned correctly.
5. Position the connector so it is centered on the end of the pack. Verify that the battery pack will not interfere with insertion of either of the door screws.
6. Reinsert screws and tighten to 12 in-lbs.

Appendix G: Weights

Adding any new instrument to an aircraft requires the installer to be aware of its weight and how that affects the overall weight and balance of the plane. The following are the weights of the EFIS-D100 and associated Dynon-supplied sensors.

Installed EFIS-D100	3 lb 0.8 oz (1.383 kg)
EFIS-D100 + battery.....	2 lb 10.7 oz (1.21 kg)
EFIS 25-pin wiring harness	11.2 oz (0.32 kg)
EDC-D10A	3.6 oz (0.102 kg)
EFIS OAT	2.6 oz (0.07 kg)
Heated AOA/Pitot Probe & Heater Controller	11.2 oz (0.32 kg)
Unheated AOA/Pitot Probe.....	5.7 oz (0.16 kg)



Appendix H: EFIS-D100 Specifications

Mechanical	6.95" wide x 4.90" tall x 4.51" deep (177 x 125 x 115 mm)
Operating Temperature	-22° to 122° F (-30° to 50° C)
Power	Voltage: 10 - 30 Vdc Power: 12 watts typical; 17 watts maximum
Connections	Wiring: DB25 male connector
Screen	Type: AMLCD, TFT (Thin Film Transistor) Backlight: 400 nits (or 800 nits, if super-bright option purchased) Size: 7.0" diagonal (178 mm) Resolution: 854 x 480 color pixels
Inputs/Outputs	1 - AOA Audio Alarm 1 - RS-232 bidirectional PC communication 1 - RS-232 data inputs (GPS, SL30, etc.) 1 - RS-232 serial encoder output 1 - Dynon Smart Avionics Bus (DSAB) multidrop