



Autopilot Servo Installation Guide

RV10 Pitch

This product is not approved for installation in type certificated aircraft

Document 101046-006, Revision F

January, 2013

Copyright © 2009-2013 by Dynon Avionics, Inc.

Permission to print this manual is granted to third parties



Contact Information

Dynon Avionics, Inc.
19825 141st Place NE
Woodinville, WA 98072
Phone: (425) 402-0433 - 8:00 AM – 5:00 PM (Pacific Time) Monday – Friday
Dynon Technical Support available 7:00 AM–4:00 PM (Pacific Time) Monday – Friday
Email: support@dynonavionics.com
Fax: (425) 984-1751

Dynon Avionics offers online sales, extensive support, and frequently updated information on its products via its Internet sites:

www.dynonavionics.com –Dynon Avionics primary web site; including:
docs.dynonavionics.com – Current and archival documentation including Installation Guides.
downloads.dynonavionics.com – Software downloads.
support.dynonavionics.com – Support resources.
store.dynonavionics.com – Dynon’s *secure* online store for purchasing all Dynon products 24 hours a day.
wiki.dynonavionics.com – Dynon’s Documentation Wiki provides enhanced, extended, frequently updated online documentation contributed by Dynon employees and customers.
forum.dynonavionics.com – Dynon’s Internet forum where Dynon customers can interact with each other and Dynon Avionics. A key feature of the forum is that it allows the exchange of diagrams, photos, and other types of files.
newsletter.dynonavionics.com – Dynon’s email newsletter.
blog.dynonavionics.com – Dynon’s blog where you can find new and interesting Dynon-related content.
register.dynonavionics.com – Register your Dynon Avionics product.
license.dynonavionics.com – Redeem certificates for navigation mapping software, synthetic vision, and other features for license codes that add new functionality to your SkyView system.

Copyright

©2008-2012 Dynon Avionics, Inc. All rights reserved. No part of this manual may be reproduced, copied, transmitted, disseminated or stored in any storage medium, for any purpose without the express written permission of Dynon Avionics. Dynon Avionics hereby grants permission to download a single copy of this manual and of any revision to this manual onto a hard drive or other electronic storage medium to be viewed for personal use, provided that such electronic or printed copy of this manual or revision must contain the complete text of this copyright notice and provided further that any unauthorized commercial distribution of this manual or any revision hereto is strictly prohibited.

Information in this document is subject to change without notice. Dynon Avionics reserves the right to change or improve its products and to make changes in the content without obligation to notify any person or organization of such changes. Visit the Dynon Avionics website (www.dynonavionics.com) for current updates and supplemental information concerning the use and operation of this and other Dynon Avionics products.



SERVO MOUNTING INSTRUCTIONS – RV-10 PITCH KIT

Kit Contents		
Dynon Part #	QTY	Part Description
100836-000	2	Large Male Rod End
100966-008	1	Aluminum Pushrod Tube - 3.0"
100973-000	1	RV10 Pitch Bracket
100975-002	2	AN315-4R Jam Nut
100976-011	2	AN365-1032A Nylon Insert Locknut
100977-000	2	AN970-3 Large Flat Washer
100978-003	10	AN960-10 Small Flat Washer
100979-002	4	MS35333-39 #10 Internal Star Washer
100981-000	4	AN3H-3A Bolt - 3/8"
100981-005	1	AN3H-10A Bolt - 1"
100981-006	1	AN3H-11A Bolt - 1 1/8"

The RV-10 pitch servo mounting kit includes a mounting bracket, pushrod linkage, and most of the required fasteners to mount the servo and properly link it to the aircraft control system. All Dynon-supplied parts are illustrated in dark grey to distinguish them from existing aircraft hardware. Refer to the drawing to locate the servo mounting bracket in the aircraft.

Fasteners along the mounting plate surface must be removed and can be re-used to secure the bracket in place. The Dynon mounting bracket must be drilled to match the existing hole pattern of the aircraft plate. Once the bracket has been drilled, fasten it to the aircraft. It is up to the installer to verify the hardware used is tightened back to aircraft specification.

With the bracket installed in the aircraft, the bell crank must be drilled. Refer to the drawing for dimensions, and use a supplied AN960-10 washer as a support between the two halves of the bell crank to avoid crushing when the linkage is fastened.

Install the 4 AN3H-3A bolts, MS35333-39 star washers, and AN960-10 flat washers to secure the servo to the bracket per the drawing, noting the orientation of the servo output arm. All AN bolts supplied by Dynon have drilled heads for use with safety wire. With the servo and bell crank additions in place, torque all fasteners back to original installation specifications and add safety wire where needed.

With the servo installed, the linkage needs to be assembled. Refer to the illustration and follow proper rod end installation techniques. Thread both large rod ends with jam nuts into the supplied 3.0" tube. Mounting of the linkage to the servo arm will include the AN3H-10A bolt, AN970-3 large diameter flat washer (for capturing the rod end bearing), 2 AN960-10 flat washers, and the AN365-1032A lock nut. The other end of the linkage will require the same type of stack-up, using the longer AN3H-11A bolt and capturing the washer sandwiched between the halves of the bell crank.

To prevent the possibility of the servo arm going over-center, the servo arm must **not** travel more than a total of +/-60° from neutral throughout the control system's range of travel. The linkage

should be installed as close to the Dynon recommendation as possible, as changes will affect geometry. Dynon suggests installing the linkage at the outer-most hole of the servo arm. Changing this location will affect servo torque output, servo arm travel, control surface resolution, and the amount of force required to shear the safety screw, and should only be changed if the installer has an understanding of these implications. See the diagram on the following page which illustrates the linear travel and available force for each mount point on standard-arm servos.

The distance between the servo arm and the control system attachment point must allow for the angle between the servo arm and the push rod to be at approximately 90° when the controls are at neutral. Use the adjustability in the rod ends to achieve this, and then tighten the jam nuts to lock the rod ends in place. Installers should always keep in mind the range of motion of the servo. Total servo arm travel is limited, but verify the arm/linkage do not interfere with anything during the full motion of the control stick. The built in control stops of the aircraft will limit the servo arm travel when installed correctly. We recommend the use of the optional Range of Motion Limiting Bracket, supplied with the servo to eliminate the chance of the servo arm going over-center. This bracket should not be used as a normal stop; the aircraft's built-in stops should always be the primary range limit.

Your servo(s) and AP74/76 (if ordered) came with a CD containing the latest documentation for all Dynon products (also available at dynonavionics.com). Please read through that documentation to understand the wiring and configuration process for your Autopilot system. We also maintain a collaborative set of this documentation, which is often updated with new information by both Dynon and fellow builders. Visit wiki.dynonavionics.com to view and contribute to the latest version of these documents.

You can also visit forum.dynonavionics.com to discuss and share installation notes, pictures, and suggestions with other builders.



Neglecting to properly install and/or use Dynon autopilot hardware may result in failures which could cause loss of aircraft control resulting in aircraft damage, personal injury or death.

Wiring Overview

The following diagram provides an overview of the autopilot-specific wiring installation. For the complete set of wiring and configuration instructions, please see the latest Installation Guide for your Dynon EFIS product. For a SkyView system please reference the **Autopilot Servo Installation, Configuration, and Calibration** chapter of your SkyView System Installation guide. For EFIS-D10A, EFIS-D100 or FlightDEK-D180 please reference the **Autopilot Installation and Configuration** chapter of each respective Installation Guide.

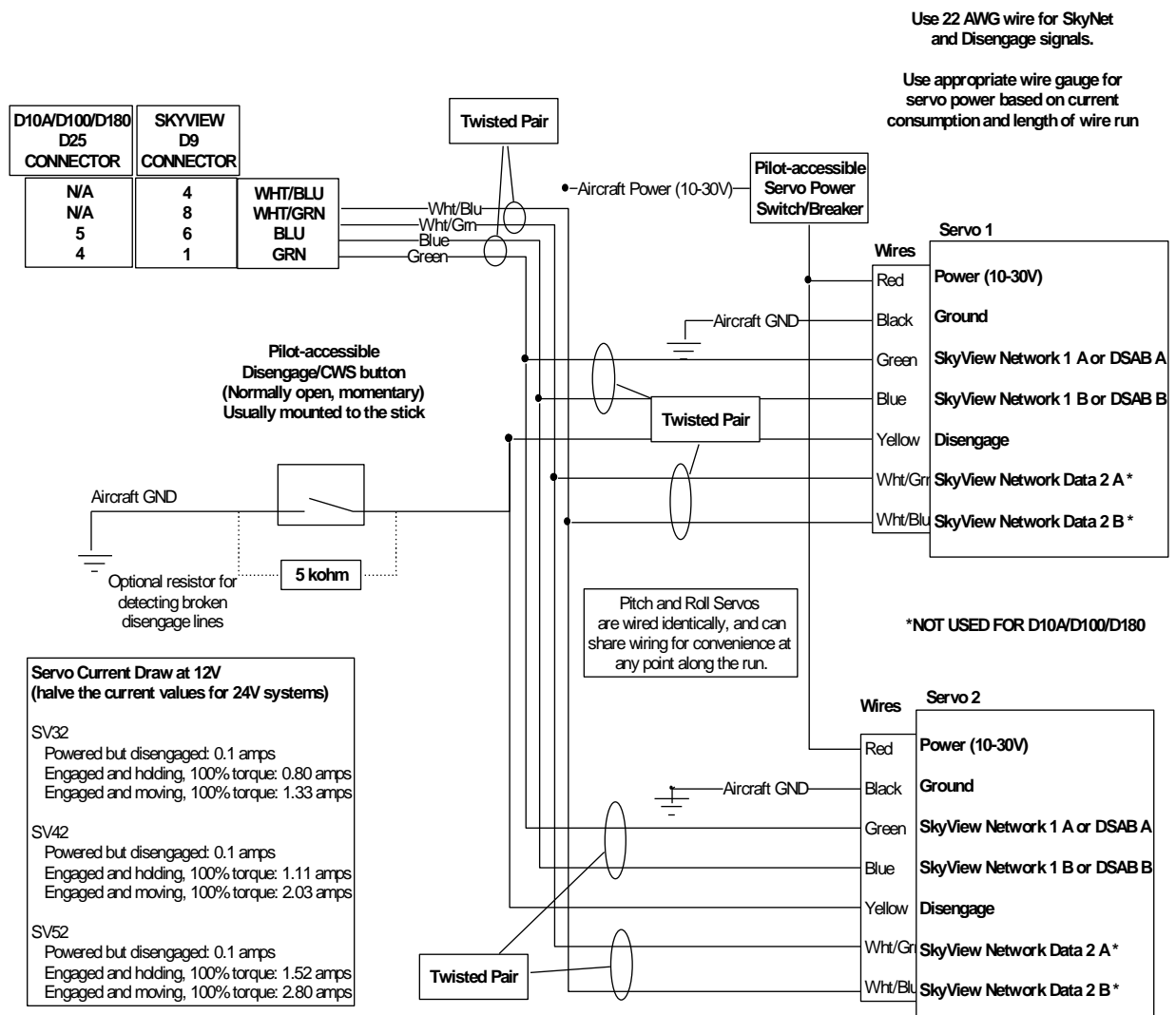



Servo Dimensions

Use the following dimensions (in inches) for reference when planning and implementing your installation.

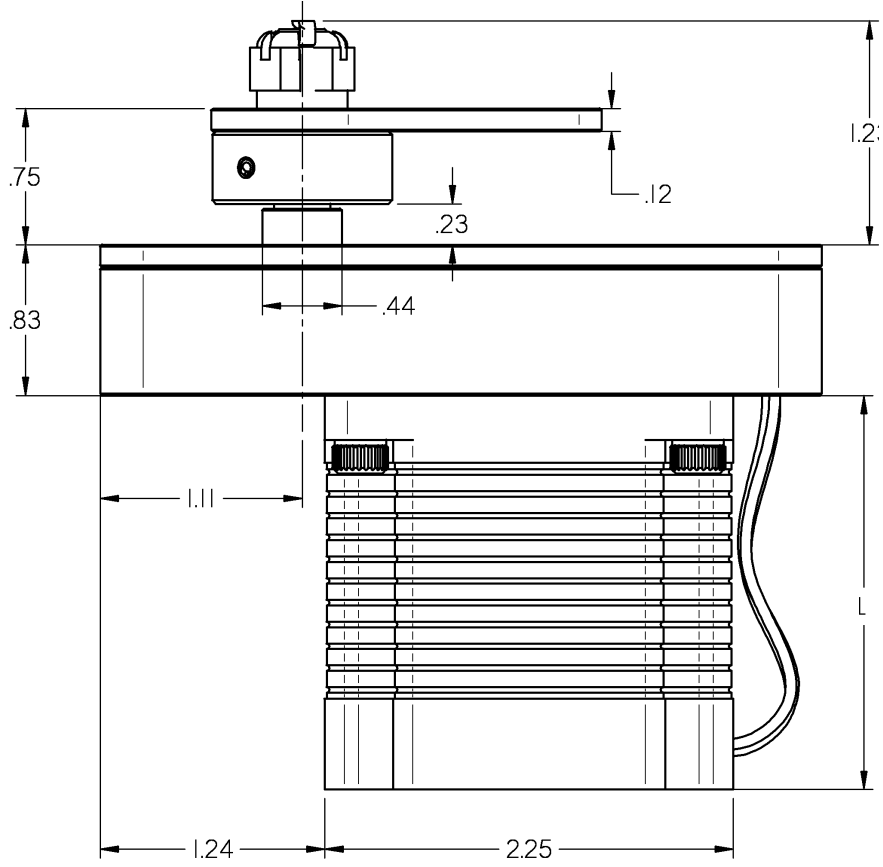
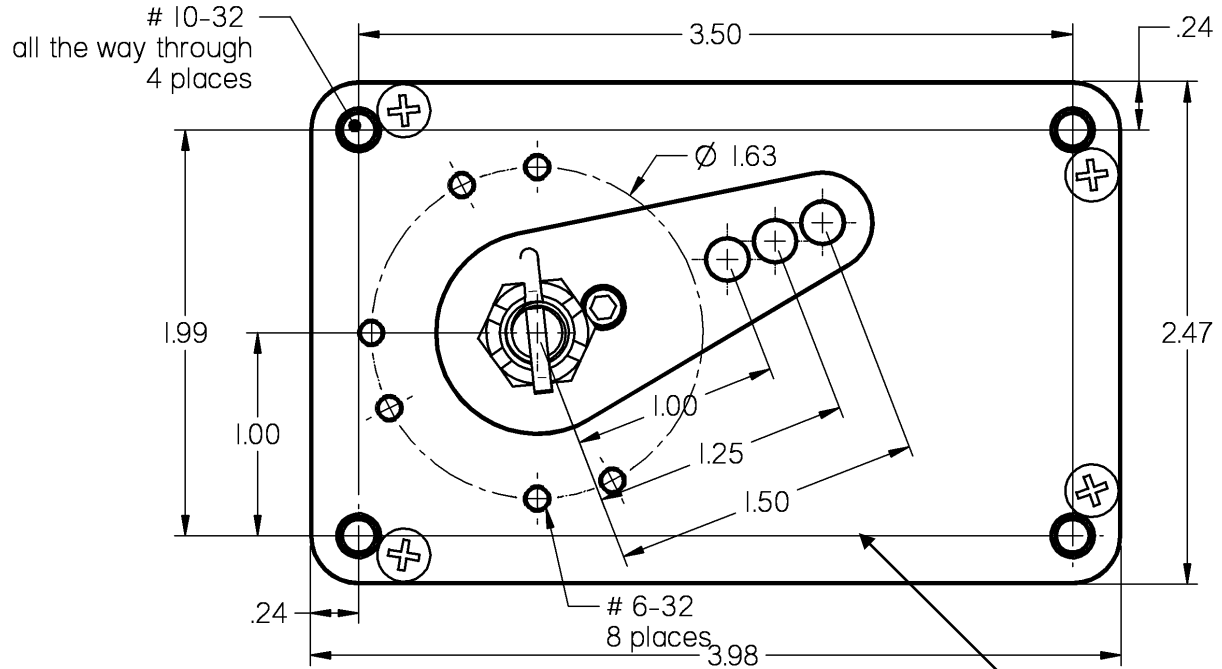

Long-arm variants (as used for RV-6 Roll) have linkage mount holes at 1.5", 1.75", and 2.0"

	L	Weight
SV32	2.17"	2 lb
SV42	3.10"	3 lb
SV52	4.02"	4 lb

Linkage mount position force and travel

The diagram below illustrates the maximum travel and force available at each linkage mounting point. As can be seen, the closer you mount the linkage to the shaft, the more force the servo can deliver. However, this also means the travel of the arm is shorter. Again, ensure that the servo arm is nowhere near going over-center throughout the entire range of the control system.

Position A should be used in most RV-6 roll installations. Modify mount position with caution and take all precautions to ensure that a near over center condition cannot occur.

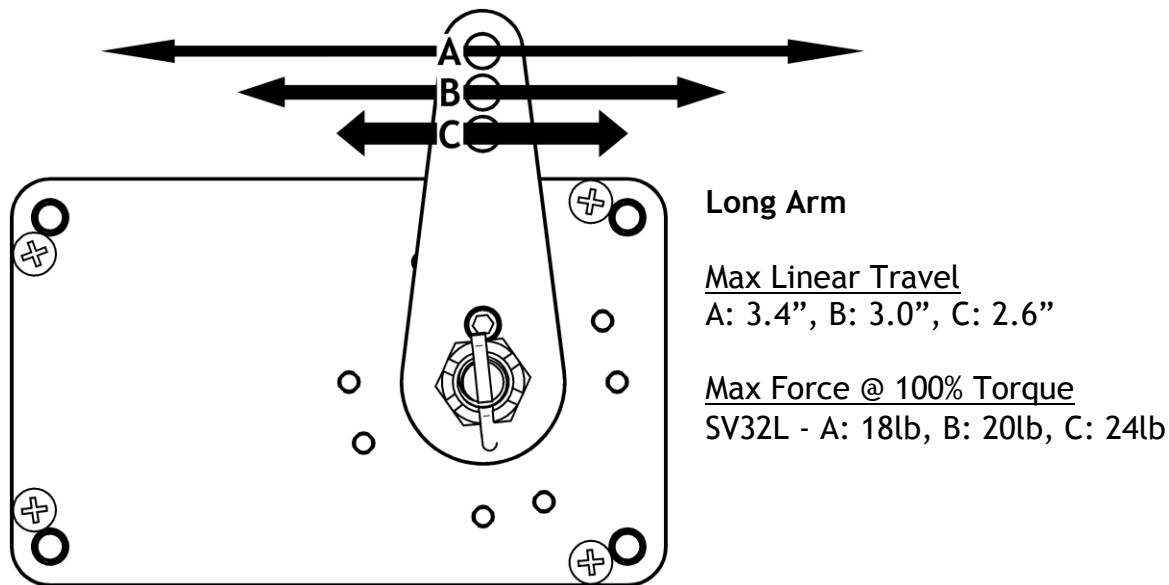

- ! The autopilot safety shear screw should NEVER be removed or adjusted during this operation. If the shear screw has broken and needs replacement, there is specific documentation available for this purpose at <http://docs.dynonavionics.com>.

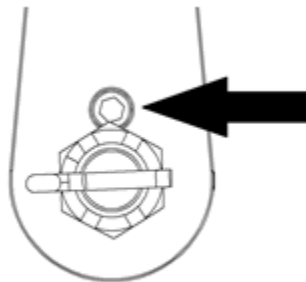

Mounting Drawings

The following pages provide detailed views of the mounting and assembly of the servo and this kit.

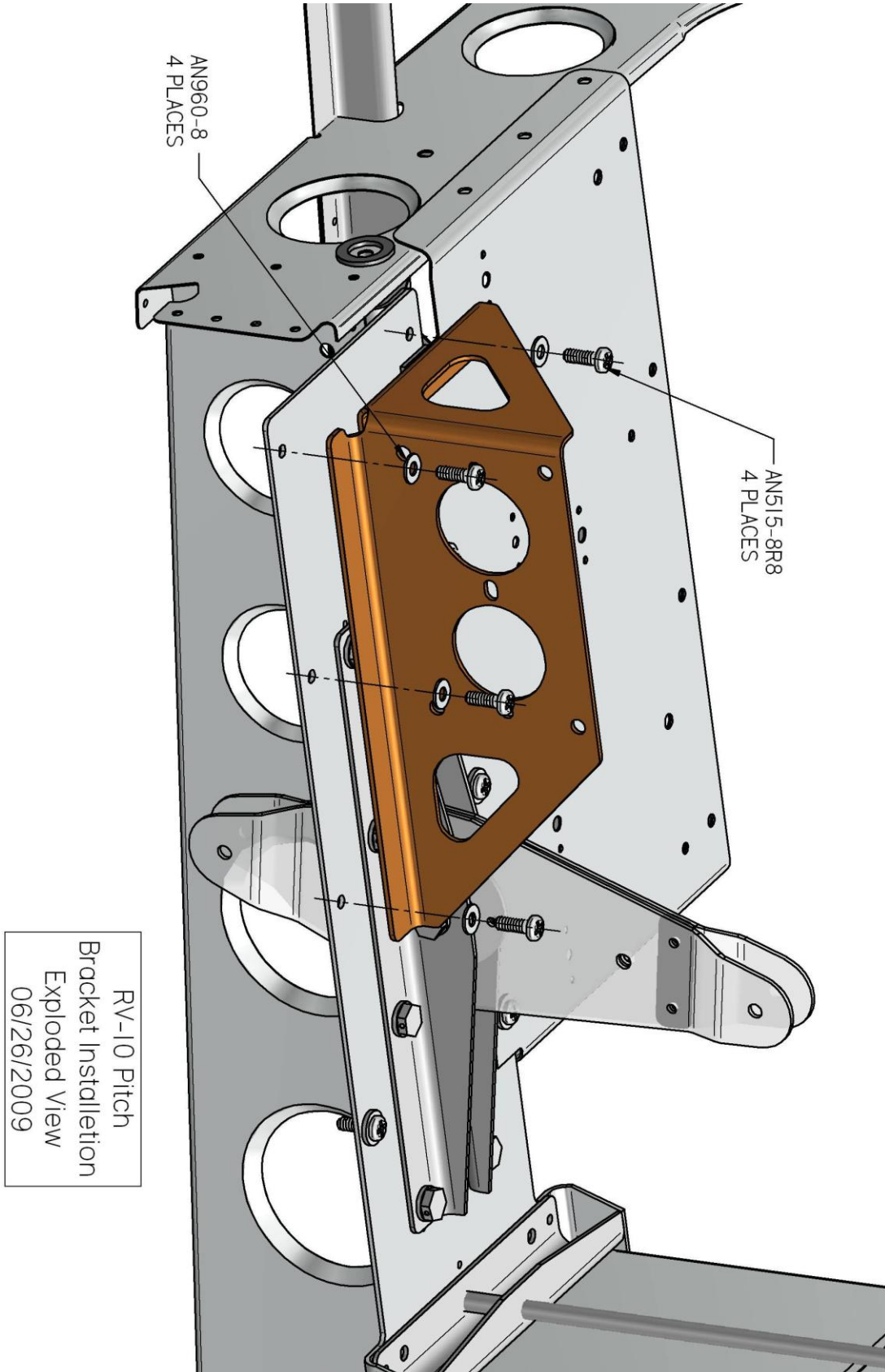

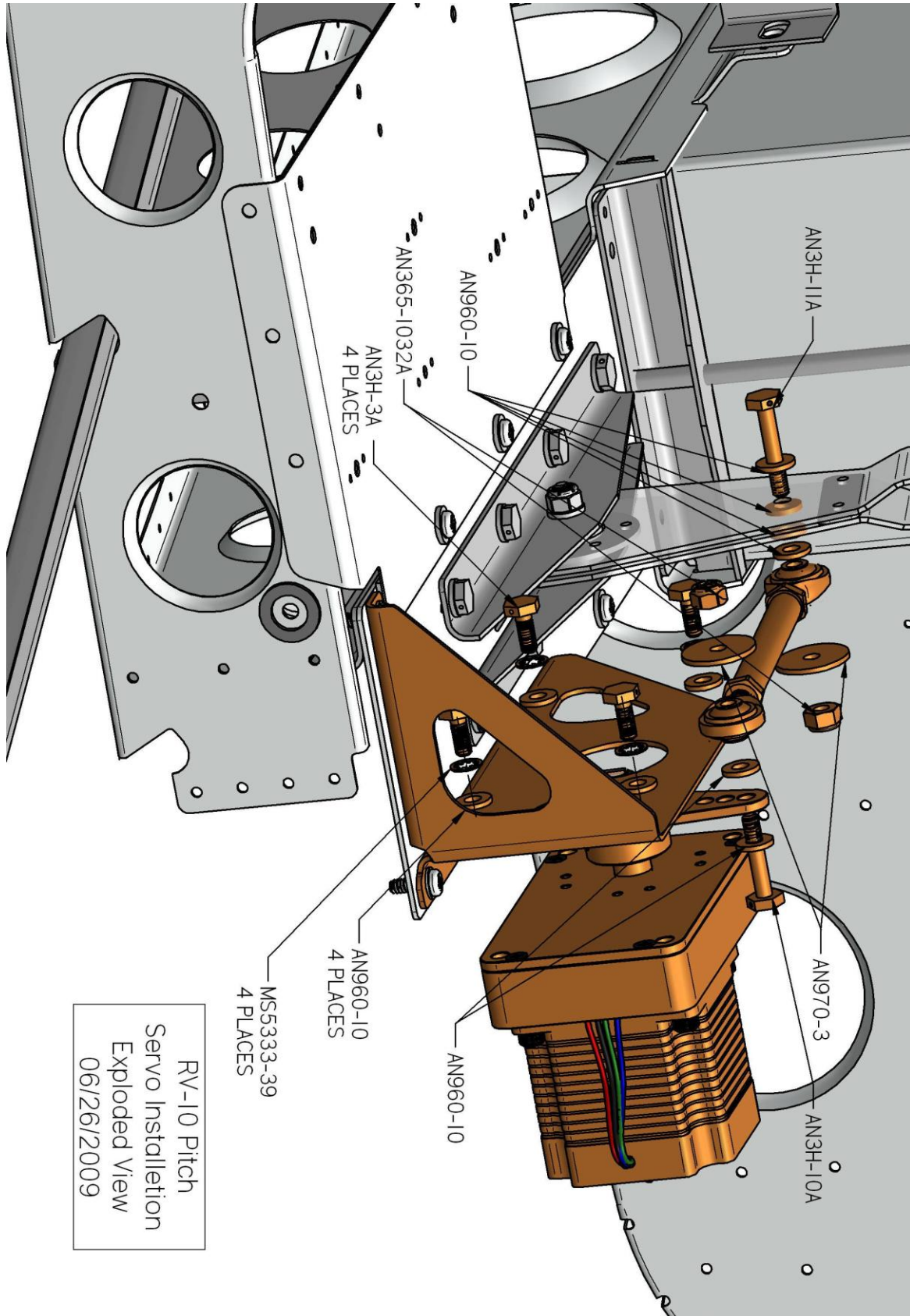

RV-10 Pitch
Servo Installation
Exploded View
06/26/2009

