



Autopilot Servo Installation Guide

RV10 Pitch for Linear Actuator

This product is not approved for installation in type certificated aircraft

Document 101046-007, Revision E

June, 2013

Copyright © 2009-2013 by Dynon Avionics, Inc.

Permission to print this this manual is granted to third parties



Contact Information

Dynon Avionics, Inc.
19825 141st Place NE
Woodinville, WA 98072
Phone: (425) 402-0433 - 8:00 AM – 5:00 PM (Pacific Time) Monday – Friday
Dynon Technical Support available 7:00 AM–4:00 PM (Pacific Time) Monday – Friday
Email: support@dynonavionics.com
Fax: (425) 984-1751

Dynon Avionics offers online sales, extensive support, and frequently updated information on its products via its Internet sites:

www.dynonavionics.com –Dynon Avionics primary web site; including:
docs.dynonavionics.com – Current and archival documentation including Installation Guides.
downloads.dynonavionics.com – Software downloads.
support.dynonavionics.com – Support resources.
store.dynonavionics.com – Dynon’s *secure* online store for purchasing all Dynon products 24 hours a day.
wiki.dynonavionics.com – Dynon’s Documentation Wiki provides enhanced, extended, frequently updated online documentation contributed by Dynon employees and customers.
forum.dynonavionics.com – Dynon’s Internet forum where Dynon customers can interact with each other and Dynon Avionics. A key feature of the forum is that it allows the exchange of diagrams, photos, and other types of files.
newsletter.dynonavionics.com – Dynon’s email newsletter.
blog.dynonavionics.com – Dynon’s blog where you can find new and interesting Dynon-related content.
register.dynonavionics.com – Register your Dynon Avionics product.
license.dynonavionics.com – Redeem certificates for navigation mapping software, synthetic vision, and other features for license codes that add new functionality to your SkyView system.

Copyright

©2008-2012 Dynon Avionics, Inc. All rights reserved. No part of this manual may be reproduced, copied, transmitted, disseminated or stored in any storage medium, for any purpose without the express written permission of Dynon Avionics. Dynon Avionics hereby grants permission to download a single copy of this manual and of any revision to this manual onto a hard drive or other electronic storage medium to be viewed for personal use, provided that such electronic or printed copy of this manual or revision must contain the complete text of this copyright notice and provided further that any unauthorized commercial distribution of this manual or any revision hereto is strictly prohibited.

Information in this document is subject to change without notice. Dynon Avionics reserves the right to change or improve its products and to make changes in the content without obligation to notify any person or organization of such changes. Visit the Dynon Avionics website (www.dynonavionics.com) for current updates and supplemental information concerning the use and operation of this and other Dynon Avionics products.



INSTRUCTIONS - RV-10 PITCH KIT FOR LINEAR ACTUATOR

Dynon Part #	QTY	Part Description
100836-000	1	Large Male Rod End
100973-002	1	RV10 Pitch Bracket for Linear Actuator
100975-002	1	AN315-4R Jam Nut
100976-011	1	AN365-1032A Nylon Insert Locknut
100977-000	1	AN970-3 Large Flat Washer
100978-003	3	AN960-10 Small Flat Washer
100979-002	4	MS35333-39 #10 Internal Star Washer
100981-000	4	AN3H-3A Bolt - 3/8"
100981-009	1	AN3H-14A Bolt - 1 1/2"
100982-001	1	Aluminum Spacer - 0.485"

The RV-10 pitch mounting kit includes a mounting bracket for use with the linear actuator and most of the required fasteners to mount the servo and properly link it to the aircraft control system. Refer to the drawings to locate the servo mounting bracket in the aircraft.

Fasteners along the mounting plate surface must be removed and can be re-used to secure the bracket in place. The Dynon mounting bracket must be drilled to match the existing hole pattern of the aircraft plate. Once the bracket has been drilled, fasten it to the aircraft. It is up to the installer to verify the hardware used is tightened back to aircraft specification. With the bracket installed in the aircraft, the bell crank must be drilled with a #12 drill bit for a .189 inch hole diameter. Refer to Fig 4 for hole placement. Install the 4 AN3H-3A bolts and MS35333-39 star washers to secure the servo to the bracket per the drawing. All AN bolts supplied by Dynon have drilled heads for use with safety wire. With the servo and bell crank additions in place, torque all fasteners back to original installation specifications and add safety wire where needed.

Thread the rod end with jam nut into the end of the linear actuator closest to the bell crank. Refer to the illustration and follow proper rod end installation techniques. Connecting the linear actuator to the elevator bell crank will require the AN3H-14A bolt, AN970-3 large diameter flat washer (for capturing the rod end bearing), 3 AN960-10 flat washers, the 0.485" aluminum spacer, and the AN365-1032A lock nut. Verify the control stick is set to neutral and the linear actuator travel is approximately centered, adjusting the rod end as needed to achieve this. Once the linkage is tightened, move the stick to full pitch up and down and verify the linear actuator is not restricting further movement.

Your servo(s) and AP74/76 (if ordered) came with a CD containing the latest documentation for all Dynon products (also available at dynonavionics.com). Please read through that documentation to understand the wiring and configuration process for your Autopilot system. We also maintain a collaborative set of this documentation, which is often updated with new information by both Dynon and fellow builders. Visit wiki.dynonavionics.com to view and contribute to the latest version of these documents. Also visit forum.dynonavionics.com to discuss and share installation notes, pictures, and suggestions with other builders.

Wiring Overview

The following diagram provides an overview of the autopilot-specific wiring installation. For the complete set of wiring and configuration instructions, please see the latest Installation Guide for your Dynon EFIS product. For a SkyView system please reference the **Autopilot Servo Installation, Configuration, and Calibration** chapter of your SkyView System Installation guide. For EFIS-D10A, EFIS-D100 or FlightDEK-D180 please reference the **Autopilot Installation and Configuration** chapter of each respective Installation Guide.

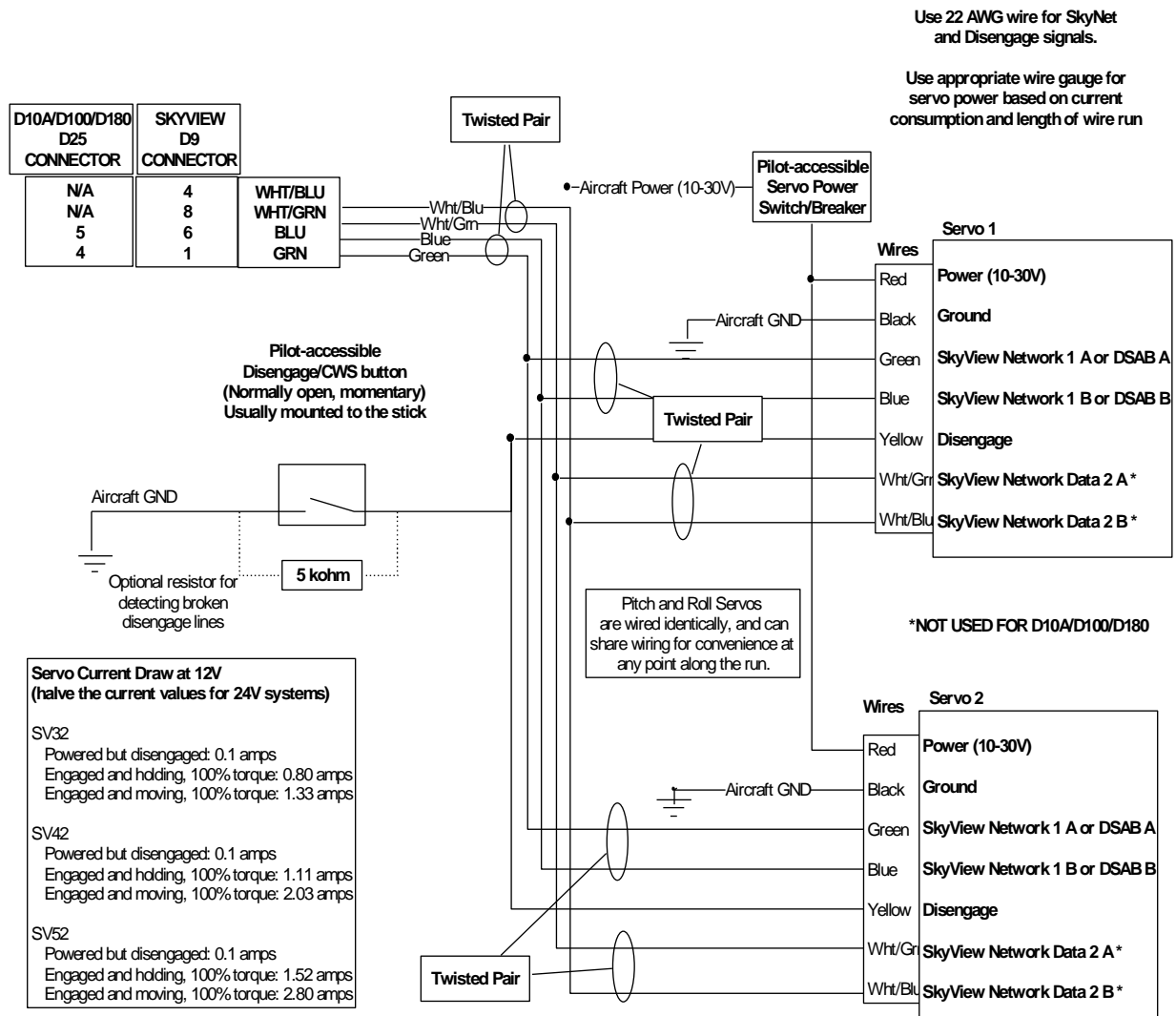



Servo Specifications

Total SV42T weight as shipped is 3.0 lbs (1.36 kg). Maximum linear travel is 3.5 in (8.9 cm). Maximum force @ 100% autopilot torque setting is 65 lbs. Use the following dimensions (in inches) for reference when planning and implementing your installation.

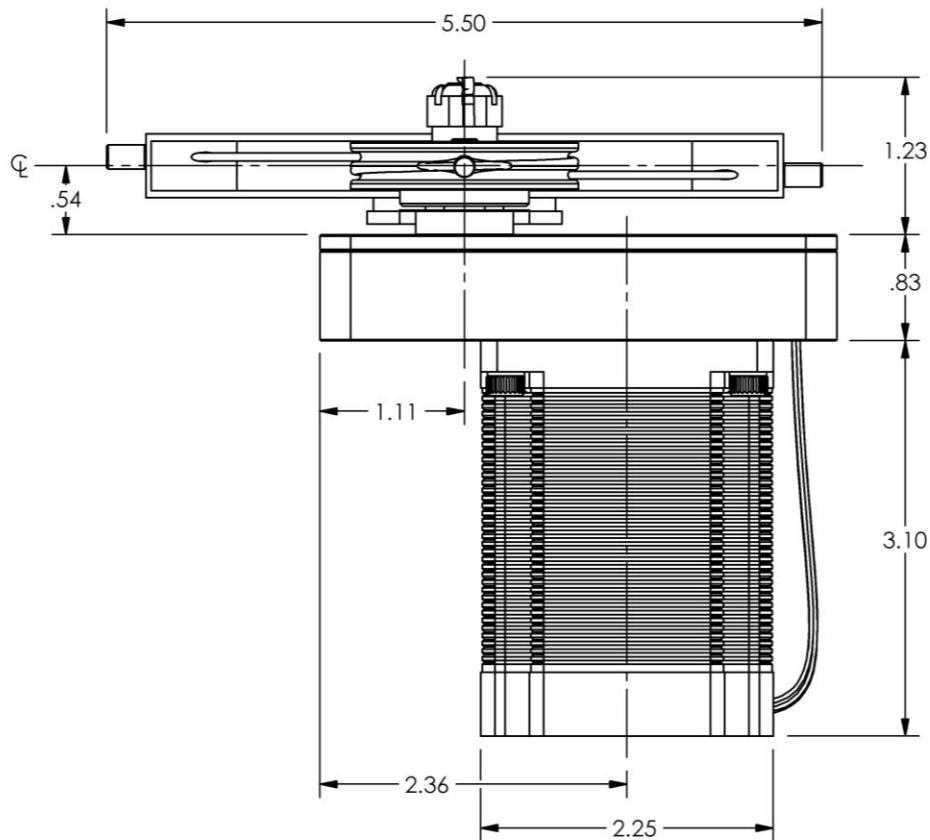
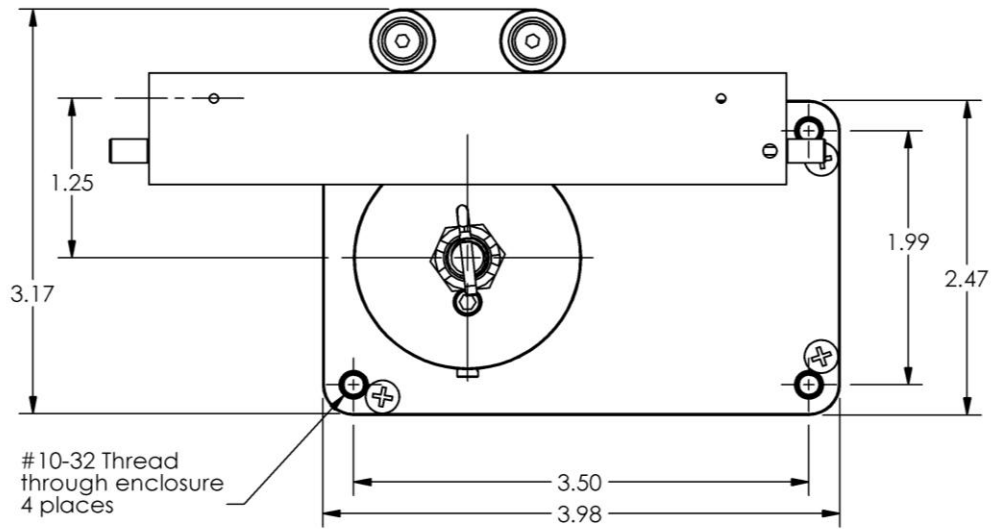

- ❗ The autopilot safety shear screw should NEVER be removed or adjusted during this operation. If the shear screw has broken and needs replacement, there is specific documentation available for this purpose at <http://docs.dynonavionics.com>.

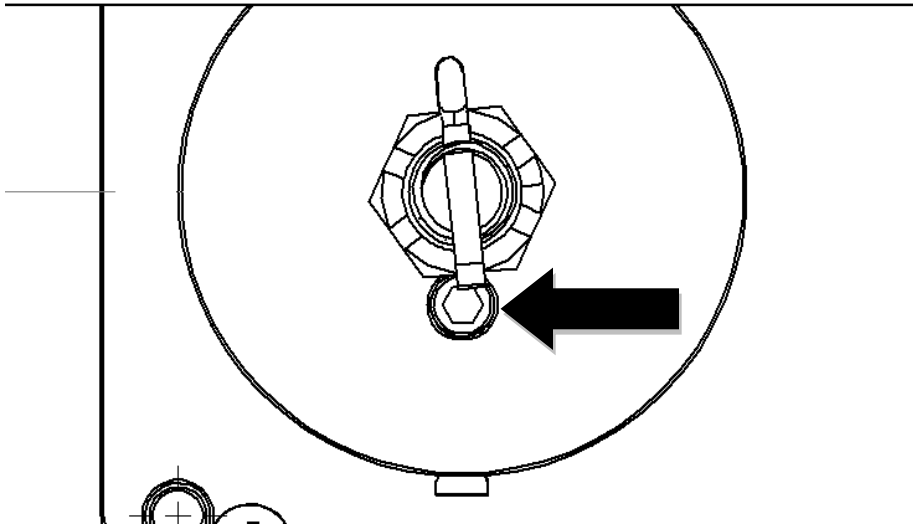

Fig 1



Neglecting to properly install and/or use Dynon autopilot hardware may result in failures which could cause loss of aircraft control resulting in aircraft damage, personal injury or death. The linear actuator should be inspected at regular intervals for pulley and cable wear, and freedom of movement.

Mounting Drawings

The following pages provide detailed views of the mounting and assembly of the servo and this kit.

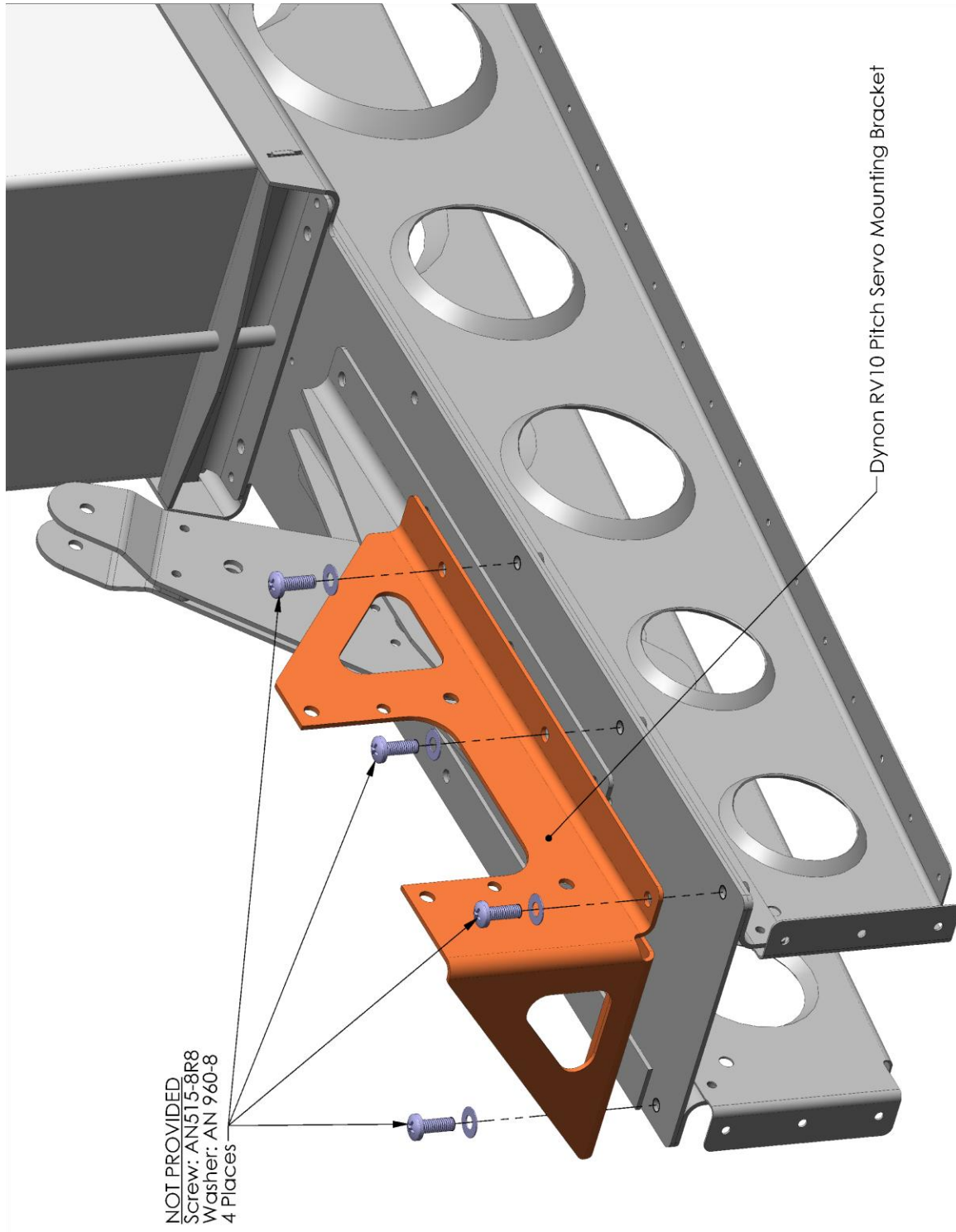

Fig 2

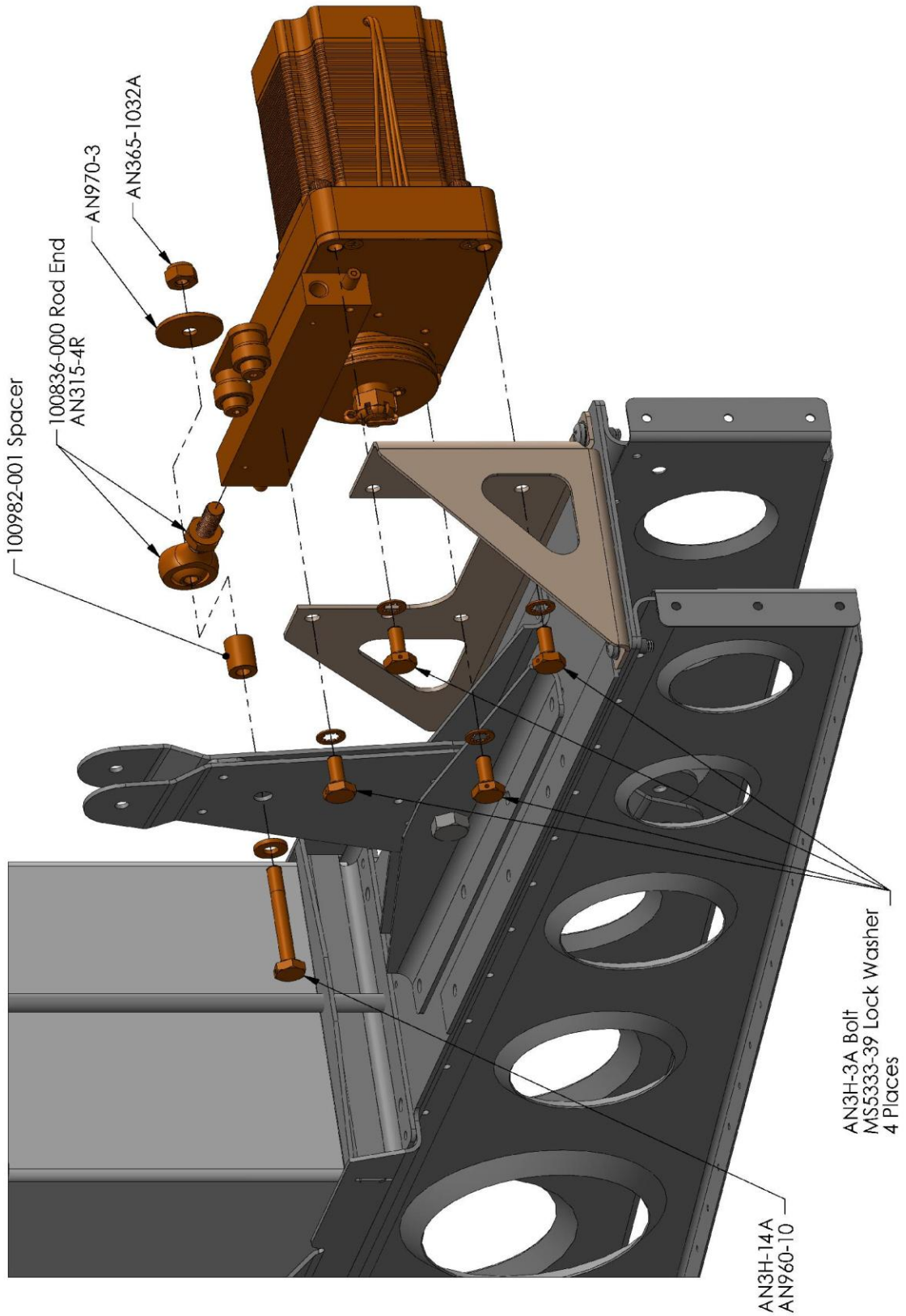

Fig 3

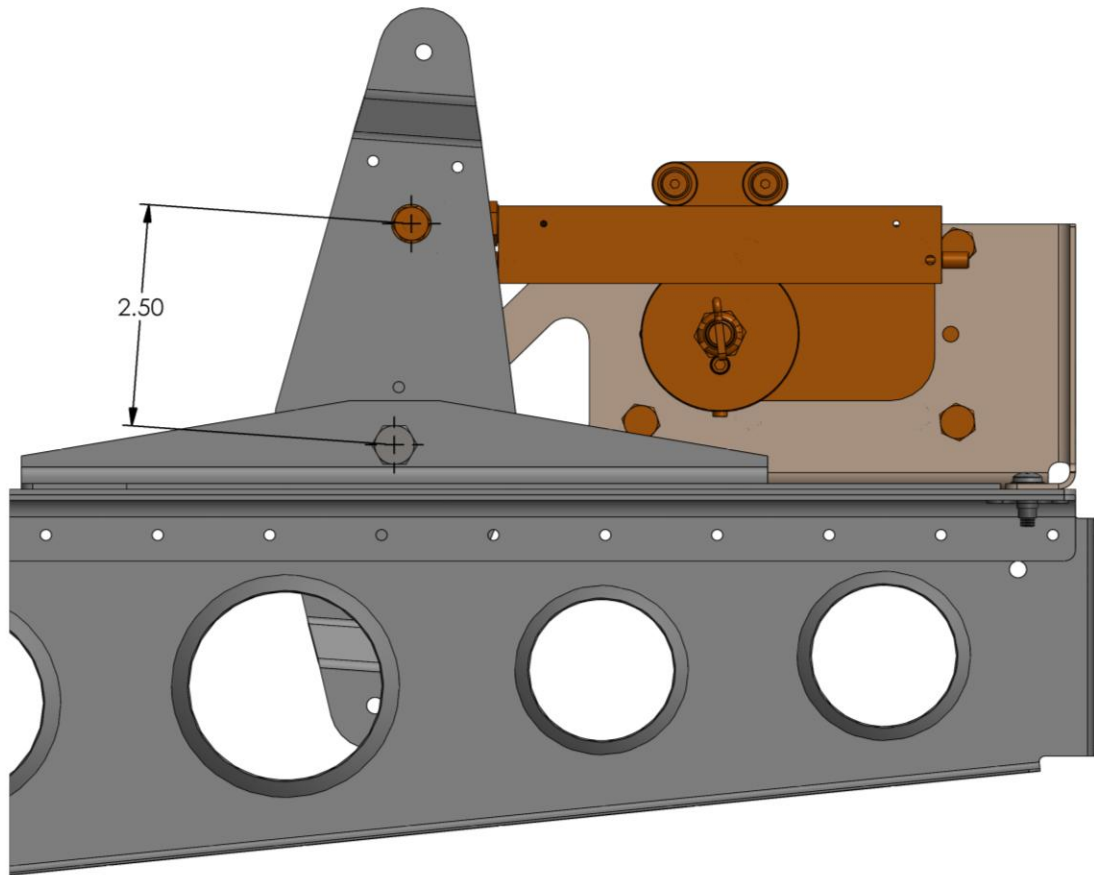
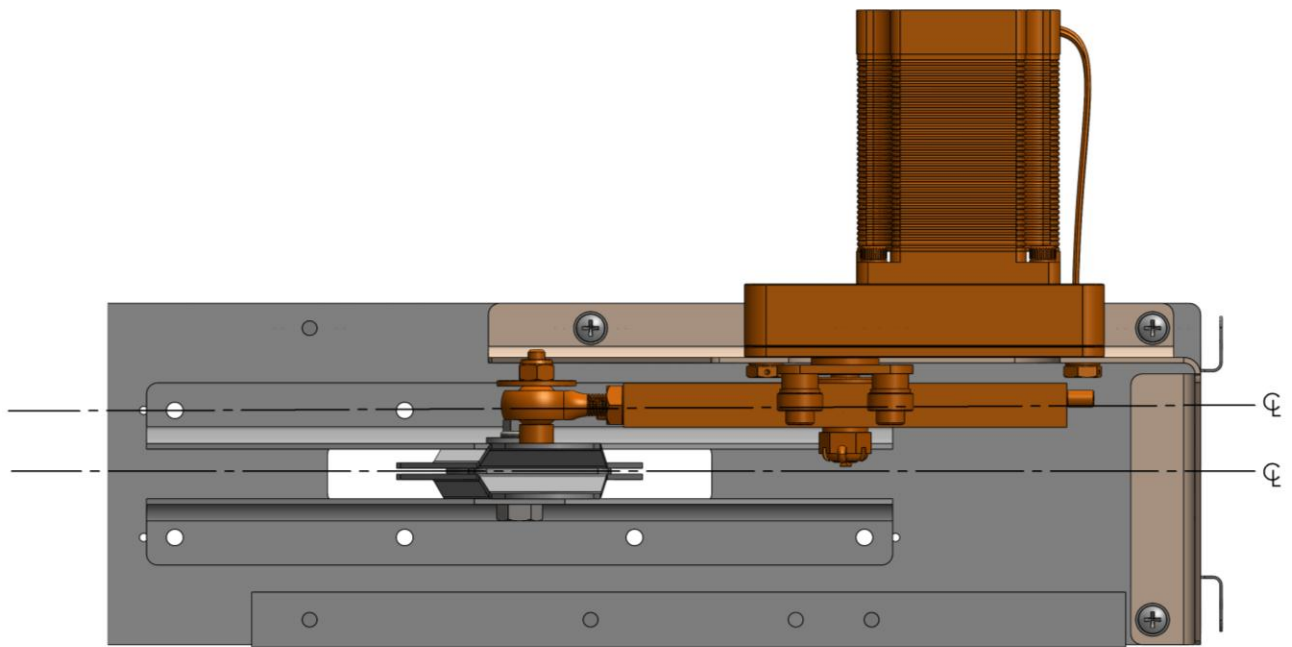

Fig 4