

Dynon Avionics Servo Range of Motion Limiting Bracket Kit Installation Instructions

Use of the limiting bracket is **optional** and should be considered an extra method of security. The bracket was designed to limit the travel of the servo arm in extreme cases to avoid control actuator over-centering.

When installed and oriented properly, **the servo arm travel should be limited to ~100° and should not come into contact with the limiting bracket at any point during full range of motion at the control stick**, as the built-in stops of the aircraft should limit travel. The multiple hole locations in the servo housing and limiting bracket allow for fine tuning of this orientation. Do not install the bracket backwards, as the arm range of motion will be limited to ~180° rendering it ineffective. **Verify servo arm travel is limited to ~100° stop to stop.**

Please use the included #6-32 screws and star washers to install the bracket to the servo. If the servo limiting bracket interferes with a servo mounting bracket, place the optional included AN960-10 washers under the bracket to space the limiting bracket above the face of the interference. Alternatively, trim the bracket to fit. **If it is necessary to use longer screws, ensure they are a length that does not allow them to penetrate the servo enclosure more than 0.175”.**

101384-001 Rev B

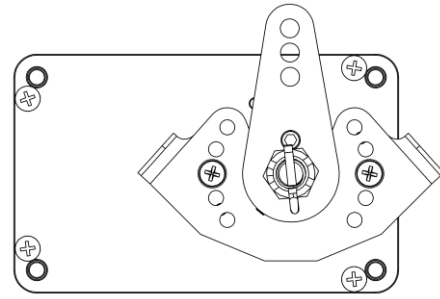

Figure 1 - Range of Motion Limiting Bracket - Front

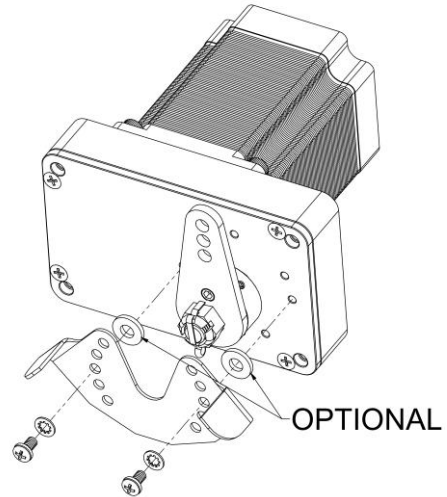

Figure 2 - Range of Motion Limiting Bracket - Isometric

Dynon Avionics Servo Range of Motion Limiting Bracket Kit Installation Instructions

Use of the limiting bracket is **optional** and should be considered an extra method of security. The bracket was designed to limit the travel of the servo arm in extreme cases to avoid control actuator over-centering.

When installed and oriented properly, **the servo arm travel should be limited to ~100° and should not come into contact with the limiting bracket at any point during full range of motion at the control stick**, as the built-in stops of the aircraft should limit travel. The multiple hole locations in the servo housing and limiting bracket allow for fine tuning of this orientation. Do not install the bracket backwards, as the arm range of motion will be limited to ~180° rendering it ineffective. **Verify servo arm travel is limited to ~100° stop to stop.**

Please use the included #6-32 screws and star washers to install the bracket to the servo. If the servo limiting bracket interferes with a servo mounting bracket, place the optional included AN960-10 washers under the bracket to space the limiting bracket above the face of the interference. Alternatively, trim the bracket to fit. **If it is necessary to use longer screws, ensure they are a length that does not allow them to penetrate the servo enclosure more than 0.175”.**

101384-001 Rev B

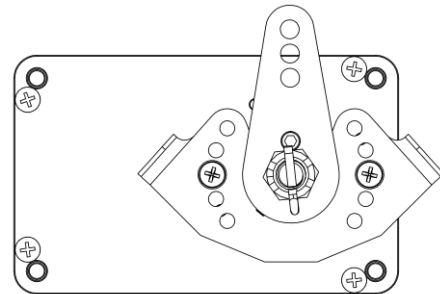

Figure 1 - Range of Motion Limiting Bracket - Front

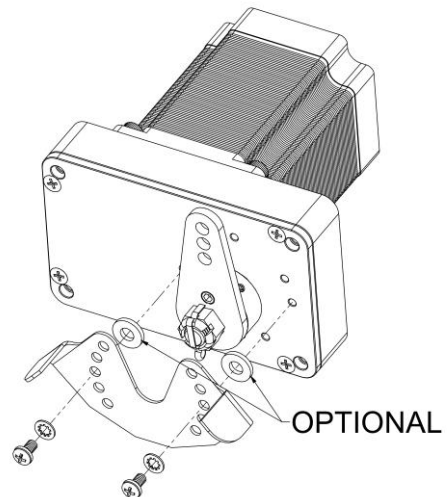

Figure 2 - Range of Motion Limiting Bracket - Isometric