

DETAIL A
SCALE 1 : 2

FOR REFERENCE ONLY
THIS PANEL WAS DESIGNED
FOR A PARTICULAR AIRCRAFT
DYNON CAN NOT GUARANTEE
FITMENT IN OTHER SIMILAR
AIRCRAFT

PANEL MADE FOR:
MODEL 172M (1979)
SERIAL # 17266295

IT IS THE RESPONSIBILITY
OF THE BUILDER TO ENSURE
THE CUT-OUT FEATURES INCLUDE
REQUIRED MARGINS NEEDED
FOR PAINT OR OTHER FINISHES
APPLIED TO THE PANEL.
FINISHES MAY REDUCE THE
EFFECTIVE SIZE OF THE CUT-OUT

PANEL RH
C172
GENERIC



19825 141st PI NE
Woodinville, WA 98072
425-402-0433
www.dynonavionics.com

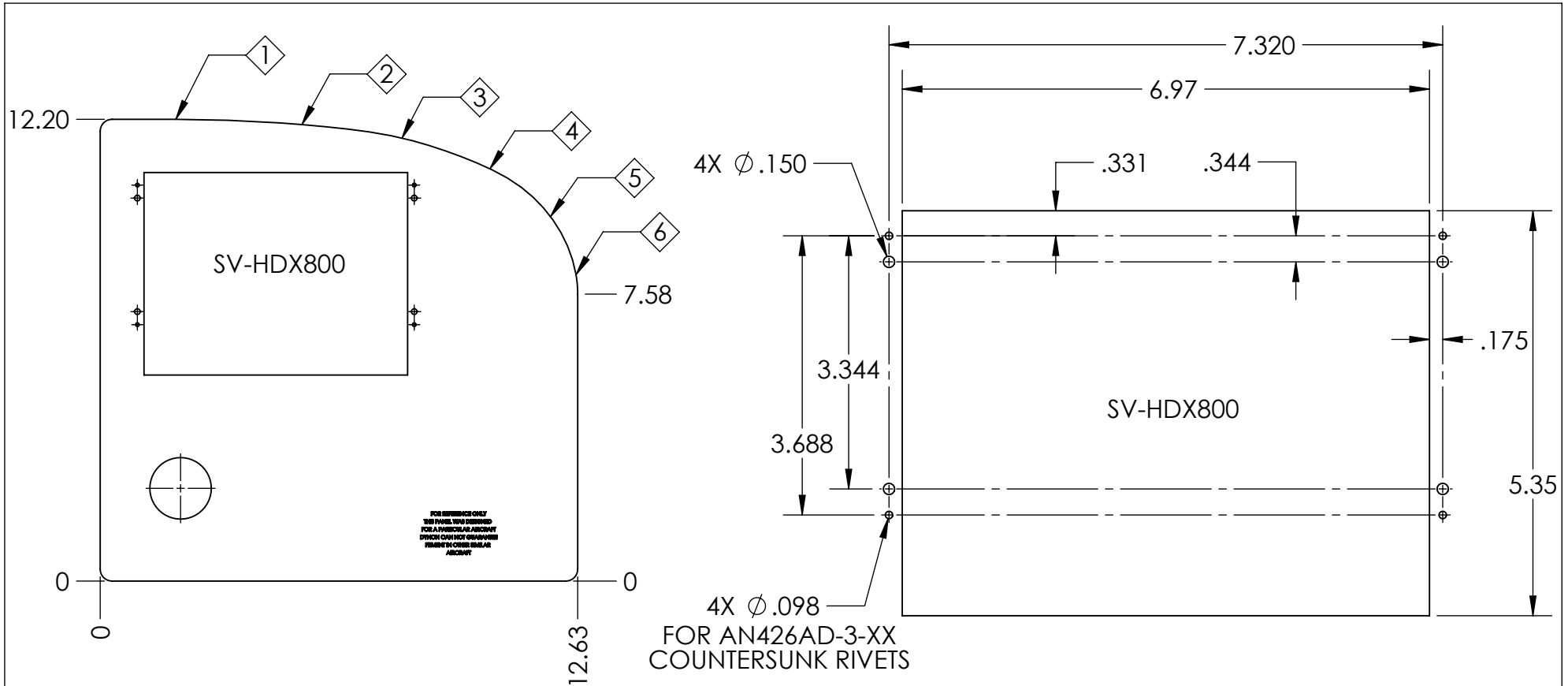

DETAIL B
SCALE 1 : 2

NOTE: CONTACT DYNON FOR DATA FILE

POSITION #	X POSITION INCHES	Y POSITION INCHES
1	2.00	12.20
2	5.33	12.06
3	7.98	11.70
4	10.31	10.89
5	11.91	9.63
6	12.58	8.09

PANEL RH
C172
GENERIC



19825 141st PI NE
Woodinville, WA 98072
425-402-0433
www.dynonavionics.com