



SkyView HDX

Autopilot Servo Installation & Maintenance Manual

Piper PA-34 Seneca Series

(PA-34-200T Seneca II, PA-34-220T Seneca III, IV, V)

Includes Instructions for Continued Airworthiness (ICA)

STC SA02594SE

103741-000

Copyright © 2022 by Dynon Avionics, Inc.

Dynon grants third parties' permission to print this document

Contact Information

Dynon Avionics, Inc.
19825 141st Place NE
Woodinville, WA 98072

Technical Support

Phone: +1 (425) 399-7742, 8:00 AM – 5:00 PM (Pacific Time) Monday – Friday
Email: support@dynoncertified.com

Sales

Phone: +1 (425) 650-1269, 8:00 AM – 5:00 PM (Pacific Time) Monday – Friday
Email: sales@dynoncertified.com

Find Us on the Web

dynoncertified.com – Dynon Certified homepage
dynoncertified.com/docs – Product documentation
dynoncertified.com/download – Software updates for products
dynoncertified.com/support – Support resources
dynoncertified.com/register – Register your Dynon Avionics product

Stay in Touch

dynoncertified.com/newsletter – Sign up to receive Dynon’s newsletter
forum.flydynon.com – Dynon-hosted forum for customers and pilots
preflight.dynon.com – Dynon’s blog
facebook.com/dynonavionics
instagram.com/dynonavionics
twitter.com/dynon

Videos and Training

youtube.com/DynonAvionics – Training, events, and other videos on YouTube

Copyright

©2022 Dynon Avionics, Inc. All rights reserved. No part of this manual may be reproduced, copied, transmitted, disseminated, or stored in any storage medium, for any purpose without the express written permission of Dynon Avionics. Dynon Avionics hereby grants permission to download a single copy of this manual and of any revision to this manual onto a hard drive or other electronic storage medium to be viewed for personal use, provided that such electronic or printed copy of this manual or revision must contain the complete text of this copyright notice and provided further that any unauthorized commercial distribution of this manual or any revision hereto is strictly prohibited.

Information in this document is subject to change without notice. Dynon Avionics reserves the right to change or improve its products and to make changes in the content without obligation to notify any person or organization of such changes. Visit the Dynon Avionics website (dynon.com) for current updates and supplemental information concerning the use and operation of this and other Dynon Avionics products.

Revision History

REV	DYNON SUBMITTAL	FAA ACCEPTANCE	DESCRIPTION OF CHANGES
A	8/6/2020 ECO 330214	Not Accepted	Initial Submission
B	12/10/2020 ECO 363506	Not Accepted	<ul style="list-style-type: none"> Removed airplane exception from cover page. Added Section 5.3.2: Airplanes Equipped with Pneumatic De-Ice Boots. Added Appendix A: Pneumatic Tube Rerouting
C	12/16/2020 ECO 364551	Accepted by Seattle ACO on 12/18/2020	<ul style="list-style-type: none"> Added requirement to Appendix A for functional check of de-ice system following re-routing of pneumatic plumbing.
D	3/24/2021 ECO 367004	Accepted as Minor Change by Seattle ACO on 4/6/2021	<ul style="list-style-type: none"> Updated Table 1 and 2 with corrected Dynon P/N for 1/8" Control Cable kit (503560-000 to 503674-000). Updated Table 1 and 2 with corrected AN# for hex bolt in 1/8" Control Cable kit (AN3H-6A to AN3-6A).
E	1/6/2022 ECO 375778	N/A – Typo Fix Only	<ul style="list-style-type: none"> Updated Contact Information section and links within doc with current URL addresses. Fixed hardware name typos in Table 1 and Table 2.
F	4/21/2022 ECO 379164	Accepted as Minor Change by Seattle ACO on 1/18/2022	<ul style="list-style-type: none"> Updated Cover Page to include STC # and footer per FAA requests in like documents. Updated Introduction section to include information requested by FAA in like documents. Added Section 2: Airworthiness Limitations section per FAA requests in like documents. Subsequent sections renumbered.

Table of Contents

1	Introduction	1
1.1	Document Control	1
1.2	Using this Manual.....	1
1.3	Intended Audience	1
1.4	Manual Iconography.....	2
1.5	Reference Documents.....	2
1.6	Mechanical Drawings	2
1.7	Product Delivery.....	2
1.8	Product Registration.....	3
1.9	Installation Record	3
2	Airworthiness Limitations.....	4
3	Installation Compliance	5
3.1	Pre-installation Information.....	5
4	Control Cable Verification.....	6
5	Materials.....	7
6	Servo Bracketry Installation and Bridle Cable Preparation.....	9
6.1	Roll Servo Bracketry Installation.....	9
6.2	Roll Servo Bridle Cable Preparation	13
6.3	Pitch Servo Bracketry Installation	15
6.4	Pitch Servo Bridle Cable Preparation	20
7	Servo Electrical Wiring.....	22
8	Servo Maintenance	23
8.1	Roll Servo Removal and Installation.....	23
8.2	Pitch Servo Removal and Installation	27
8.3	Servo Calibration Procedure	30
8.4	Servo Test Procedure	31
8.5	Servo Capstan Removal and Re-installation	31
8.6	Cable Guard Adjustment	32
8.7	Servo Shear Screw Replacement.....	32
9	Figures.....	33

9.1	Servo Locations and Access	33
9.2	Roll Servo Parts, Assemblies, and Installation.....	34
9.3	Pitch Servo Parts, Assemblies, and Installation.....	46
9.4	Servo Capstan and Cable Guard Installation.....	56
10	Appendix A: Pneumatic Tube Rerouting	57

This page intentionally left blank.

1 Introduction

This document provides installation and configuration information for SkyView HDX autopilot servos and bracketry in Piper PA-34 Seneca series of airplanes. It also provides Instructions for Continued Airworthiness (ICA) for use by authorized personnel to service and maintain the servos according to Federal Aviation Regulation (FAR) 14 CFR § 23.1529 and 14 CFR 23 Appendix G.

This document does not provide ICA for the SkyView HDX system or the EFIS-D10A Standby Flight Display. That information is provided in the *SkyView HDX General Maintenance Manual* document and the *EFIS-D10A Installation & Maintenance Manual* document at dynoncertified.com/docs.

1.1 Document Control

This document is released, archived, and controlled according to the Dynon Avionics document control system. To revise this document, a letter is submitted to the FAA with the revision. The FAA then accepts and approves any revision to Section 2: [Airworthiness Limitations](#). After FAA acceptance/approval, Dynon posts the revised document for customer use at dynoncertified.com/docs, and STC owners and installers are notified of the new revision via an official Dynon Marketing email release.

1.2 Using this Manual

To save paper, Dynon Avionics does not provide a printed version of this manual. However, Dynon grants permission to third parties to print this manual, as necessary. The most recent PDF version is available for download at dynoncertified.com/docs. This manual is updated periodically. It is important to use the most recent version when servicing SkyView components.

Dynon suggests keeping a PDF version of the manual on a smartphone, tablet, or laptop computer while servicing SkyView components. Using the manual electronically allows quick navigation of the document, figures to be viewed in color, and keyword searches.

1.3 Intended Audience

This document is intended for FAA-certified Airframe and Powerplant Technicians. It assumes technicians have the typical aircraft knowledge and training required to perform the procedures in this manual.

1.4 Manual Iconography

This manual uses the following iconography:



Alerts reader to critical guidance that if not followed could result in an unsafe condition.



Alerts reader to FAA regulatory information.



Alerts reader to important installation and/or maintenance information.



Alerts reader to helpful tips or suggestions.

1.5 Reference Documents

The following documents are referenced in or supplement this manual:

- 103261-000 SkyView HDX System Installation Manual, *current revision*
- 103914-000 EFIS-D10A Installation & Maintenance Manual, *current revision*
- 103221-000 SkyView HDX General Maintenance Manual, *current revision*
- 103488-000 SkyView HDX Wiring Diagram - Single Engine, *current revision*
- 103272-000 SkyView HDX Airplane Flight Manual Supplement, *current revision*
- 103777-000 SkyView HDX System Equipment Installation Record, *current revision*
- 103000-000 Dynon Servo Shear Screw Replacement Kit Instructions, *current revision*
- FAR 23.1311-1C - Installation of Electronic Display in Part 23 Airplanes
- AC 43.13-1B - Acceptable Methods, Techniques, and Practices - Aircraft Inspection
- AC 43.13-2B - Acceptable Methods, Techniques, and Practices - Aircraft Alterations

1.6 Mechanical Drawings

All mechanical drawings included in this manual are for *reference purposes only*. They should not be scaled or copied and used as templates or patterns.

1.7 Product Delivery

Upon delivery, visually inspect all SkyView Autopilot components, brackets, fasteners, cable harnesses, and accessories for damage that may have occurred during shipping. If damage has occurred, contact Dynon Technical Support.

1.8 Product Registration

Register SkyView components at dynoncertified.com/register. Product registration verifies ownership, expedites warranty claims, and allows Dynon Avionics to send notification when product Service Bulletins and Technical Advisories are published. This site also allows owners and installers to register to receive news and product announcements from Dynon. Dynon will not share contact information with third-parties or send announcements without explicit consent.

1.9 Installation Record

The mechanic or facility performing the installation should record where the equipment has been installed in the airplane. This documentation should be entered into airplane's permanent record. Dynon provides a document template to record this information. Download the *SkyView HDX Equipment Installation Record* document at dynoncertified.com/docs.

2 Airworthiness Limitations

For any Airworthiness Limitations associated with the installation of SkyView Autopilot servos, see the *SkyView HDX General Maintenance Manual* document at dynoncertified.com/docs. It is the principal ICA document for the SkyView HDX system.

3 Installation Compliance

Airplanes on the AML meet a minimum required configuration for applicability of the STC. However, some airplanes may have been modified, and consequently, it may be difficult to use the information in this manual to completely substantiate the installation in compliance with the STC. It is the installer's responsibility to make the final determination of applicability for each individual airplane.

Prior to completing the installation, and before returning the airplane to service, the installer must complete and submit a completed Form FAA 337 - Major Repair & Alteration (Airframe, Powerplant, Propeller, or Appliance) to the appropriate FAA Flight Standards District Office. The form must include the following:

- Description of the SkyView Autopilot installation.
- Description of how the SkyView Autopilot interfaces with existing equipment and systems.
- Appropriately approved or acceptable data that demonstrates compliance.

Refer to AC 43.9-1G - Instructions for Completion of FAA Form 337 for additional information.

3.1 Pre-installation Information

Read and understand the following before proceeding with installation activities.



Always install avionics equipment in compliance with regulatory requirements found in FAR Part 23 - Airworthiness Standards: Normal Category Airplanes, Subpart G -Flightcrew Interface And Other Information.

Always install avionics equipment in accordance with the guidance and approved engineering methods outlined the following FAA documents:



- FAR 23.1311-1C - Installation of Electronic Display in Part 23 Airplanes
- AC 43.13-1B Acceptable Methods, Techniques, and Practices - Aircraft Inspection
- AC 43.13-2B Acceptable Methods, Techniques, and Practices - Aircraft Alterations



The certified mechanic who will authorize the airplane's return to service should agree with the installation plan (i.e., methods, component locations, wiring harness routing, etc.) before installation activities begin. This will help avoid potential rework should any part of the installation be found non-compliant.

4 Control Cable Verification

The SkyView HDX Autopilot system for the Piper PA-34 Seneca series of airplanes is designed to attach to the airplane's original 1/8" diameter control cables. It is important for installers to verify the diameter of the control cables before starting installation activities. The diameter of control cables should be measured in the vicinity where the autopilot servos will be installed (see [Figure 1](#)).

To gain access to this area, installers will need to remove the second row seats, carpeting, and the floor in accordance with the Piper PA-34 Seneca Service Manual. The servos will be located beneath the cabin floor between the main spar and the rear spar carry-through structures. The roll servo will be on the left-hand side of the cabin (see [Figure 1](#)); the pitch servo will be located on the right-hand side of the cabin (see [Figure 1](#)).

Control Cable Specification:

The airplane's control cables must meet the requirements for 1/8" wire rope as specified by MIL-DTL-83420.

NOMINAL DIAMETER	MINIMUM DIAMETER	DIAMETER TOLERANCE
1/8"	0.125"	+0.014"



If the airplane's original control cables are outside this specification, contact Dynon Technical Support for a resolution.

Out-of-specification control cables can cause cable clamps to slip under load, causing the bridle cable to loosen and come off the capstan.

5 Materials

The materials identified in [Table 1](#) are required to install the roll servo into a Piper PA-34 Seneca series airplane. ITEM numbers refer to call-out numbers in the figures in [Section 9.2: Roll Servo Parts, Assemblies, and Installation](#).

Table 1: Roll Servo Installation Materials

ITEM	DYNON P/N	DESCRIPTION	QTY
1	503406-000	ROLL SERVO ASSEMBLY (SV42C)	1
2	503674-000	ROLL SERVO CAPSTAN ACCESSORY KIT, 1/8" CONTROL CABLE	1
2-1		AN365-10 LOCK NUT #10-32	6
2-2		AN960 FLAT WASHER #10	6
2-3		AN3-6A HEX BOLT #10-32 X 3/4"	6
2-4		BRIDLE CABLE CLAMP 1/8"	4
2-5		BRIDLE CABLE	1
2-6		ST2-2 STOP SWAGE, 1/16" CABLE	2
3	503719-000	SENECA ROLL SERVO BASE BRACKET	1
4	503720-000	SENECA ROLL SERVO MOUNT BRACKET	1
5	503721-000	SENECA ROLL SERVO BRACE	1
6	103991-000	SENECA ROLL SERVO BRACKET HARDWARE KIT	1
6-1		AN3H-4A HEX BOLT #10-32, DRILLED HEAD	8
6-2		AN970 FLAT WASHER #10	8
6-3		AN525-10R10 WASHER-HEAD SCREW #10-32	1
6-4		MS21047L3 ANCHOR NUT #10-32, STEEL, FULL-SIZE, 2-LUG	2
6-5		MS20426AD-3-4 SOLID FLUSH MOUNT RIVET 3/32" D, 1/4" L	4
6-6		MS20470AD-4-5 SOLID UNIVERSAL HEAD RIVET 1/8" D, 5/16" L	8
6-7		MS20470AD-4-6 SOLID UNIVERSAL HEAD RIVET 1/8" D, 3/8" L	8

Items without Dynon part numbers are parts packaged in a kit.

The materials identified in [Table 2](#) are required to install the pitch servo into a Piper PA-34 Seneca series aircraft. ITEM numbers refer to call-out numbers in the figures in [Section 9.3: Pitch Servo Parts, Assemblies, and Installation](#).

Table 2: Pitch Servo Installation Materials

ITEM	DYNON P/N	DESCRIPTION	QTY
7	503933-000	PITCH SERVO ASSEMBLY (SV42C-068)	1
8	503674-000	PITCH SERVO CAPSTAN ACCESSORY KIT, 1/8" CONTROL CABLE	1
8-1		AN365-10 LOCK NUT #10-32	6
8-2		AN960 FLAT WASHER #10	6
8-3		AN3-6A HEX BOLT #10-32 X 3/4"	6
8-4		BRIDLE CABLE CLAMP 1/8"	4
8-5		BRIDLE CABLE	1
8-6		ST2-2 STOP SWAGE, 1/16" CABLE	2
9	503718-000	SENECA PITCH SERVO MOUNT BRACKET	1
10	503722-000	SENECA PITCH SERVO BASE BRACKET	1
11	503735-000	SENECA PITCH SERVO GUSSET	1
12	103992-000	SENECA PITCH SERVO BRACKET HARDWARE KIT	1
12-1		AN3-4A HEX BOLT #10-32, DRILLED HEAD	4
12-2		AN970 FLAT WASHER #10	4
12-3		AN365-832A LOCK NUT #8-32	1
12-4		AN525-832R8 PHILLIPS WASHER-HEAD SCREW #8-32 X 1/2", CADMIUM	1
12-5		AN960-8 WASHER FLAT STL #8	1
12-6		MS20470AD-4-5 SOLID UNIVERSAL HEAD RIVET 1/8" D, 5/16" L	30
12-7		MS20470AD-4-6 SOLID UNIVERSAL HEAD RIVET 1/8" D, 3/8" L	8

Items without Dynon part numbers are parts packaged in a kit.

6 Servo Bracketry Installation and Bridle Cable Preparation

This section provides instructions for installing the roll and pitch servo bracketry, and then fabricating the bridle cable assemblies that attach to the aileron and elevator control cables. The instructions apply to all Seneca model airplanes except for serial numbers 34-7570001 through 34-8170092, when equipped with pneumatic de-ice boots. These instructions assume that the areas affected by these installations are unmodified from the factory-delivered configuration.

Refer to Section 7: [Servo Electrical Wiring](#) for servo wiring information.

Refer to Section 8: [Servo Maintenance](#) to remove or install a roll servo after the bracket installation is complete.

6.1 Roll Servo Bracketry Installation

The roll servo base bracket and brace mount directly to the airplane (see [Figure 13](#) for complete installation example). The mount bracket has the roll servo fastened to it, and it is fastened to the base bracket. The roll servo brace is fastened to base bracket and the airplane's crossover cable guide assembly. The roll servo is connected to the aileron control cables by a bridle cable.



Make sure all flight control cables are rigged and tensioned in accordance with the manufacturer's servicing manual.

Failure to do so may result in poor Autopilot system performance.

6.1.1 Location and Access

The roll servo is located beneath the cabin floor between the main spar and the rear spar carry-through structures on the left-hand side of the cabin as indicated in [Figure 1](#).

Access requires removing the second-row seats, carpeting, and the floor in accordance with the Piper PA-34 Seneca Service Manual.

6.1.2 Temporary Roll Servo Base Bracket Installation

This section provides instructions for temporarily installing the mount bracket, base bracket, and brace (see [Figure 2](#)). For the mount and base brackets, different instructions are provided for airplanes with (see Section [6.1.2.1](#)) and without (see Section [6.1.2.2](#)) factory-installed autopilot servos. Follow the appropriate instructions for the airplane. Instructions are the same for all airplanes for the brace installation (see Section [6.1.2.3](#)).

6.1.2.1 Mount and Base Bracket Installation (With Factory-installed Autopilot)

Complete the following steps to temporarily install the roll servo mount bracket and base bracket in an airplane equipped *with* a factory autopilot roll servo that is installed in the same general position.

To temporarily install the mount and base brackets:

1. Remove left and right air supply ducts in accordance with the Piper PA-34 Seneca Service Manual.
2. Remove existing roll servo and its bridle cables.
3. Remove fasteners that secure existing roll servo brackets, and then remove roll servo brackets. The new servo brackets and brace utilize some existing holes through fuselage skin/structure.
4. If needed, remove rivets from crossover cable guide assembly (see [Figure 3](#)).
5. Temporarily secure roll servo to mount bracket (see [Figure 4](#)).
6. Temporarily secure mount bracket to base bracket (see [Figure 5](#)).
7. Locate bracket assembly into position so capstan is centered below and correctly aligned with aileron crossover cable (see [Figure 6](#)).
8. From outside airplane, with an assistant holding bracket assembly in place, mark 12 holes on base bracket flanges using holes in fuselage skin/structure as a guide.
9. Remove bracket assembly and inspect markings, making sure a minimum edge margin of 0.187" from center of hole is maintained for all fastener locations. If edge margin is not adequate, repeat Step #7, adjusting bracket assembly location until adequate edge margin is maintained and capstan is aligned with aileron crossover cable.
10. When satisfied edge margin requirement has been met, replace bracket assembly in position and align marks.
11. From outside airplane, with an assistant holding bracket assembly in place, match drill (#30) holes through base bracket flanges using holes in fuselage skin/structure as a guide; install temporary fasteners as you go (see [Figure 7](#) and [Figure 8](#)).
12. If needed, use rivets to fill unused holes in fuselage skin/structure.

6.1.2.2 Mount and Base Bracket Installation (Without Factory-installed Autopilot)

Complete the following steps to temporarily install the roll servo mount bracket and base bracket in an airplane not equipped with a factory autopilot pitch servo.

To temporarily install the mount and base brackets:

1. Remove rivets on crossover cable guide assembly (see [Figure 3](#)).
2. Temporarily secure roll servo to mount bracket (see [Figure 4](#)).
3. Temporarily secure mount bracket to base bracket (see [Figure 5](#)).
4. Remove existing fasteners through fuselage skin/structure where base bracket flange is parallel to structure (see [Figure 8](#)).
5. Locate bracket assembly into position so capstan is centered below and correctly aligned with aileron crossover cable (see [Figure 6](#)).
6. From outside of airplane, with an assistant holding bracket assembly in place, mark 4 holes on base bracket flange using holes in fuselage skin/structure as a guide.
7. Remove bracket assembly and inspect markings, making sure a minimum edge margin of 0.187" from center of hole is maintained for all fastener locations. If edge margin is not adequate, repeat Step #5, adjusting bracket assembly location until adequate edge margin is maintained and capstan is aligned with aileron crossover cable.
8. When satisfied edge margin requirement has been met, replace bracket assembly in position and align marks.
9. From outside airplane, with an assistant holding bracket assembly in place, match drill (#30) holes through base bracket flange using holes in fuselage skin/structure as a guide; install temporary fasteners as you go (see [Figure 7](#) and [Figure 8](#)).
10. Remove temporary fasteners and base bracket from airplane.
11. Locate and mark positions for remaining rivet holes on base bracket flanges (see [Figure 8](#)). Make sure a minimum edge margin of 0.187" from center of rivet hole is maintained.
12. Drill pilot-size holes in base bracket flanges in positions marked in Step 11.
13. Temporarily secure base bracket to fuselage skin/structure using holes drilled in Step #9.
14. From inside airplane, with an assistant holding bracket assembly in place, drill (#30) holes through base bracket flanges and fuselage skin using pilot holes as guides; install temporary fasteners as you go (see [Figure 7](#) and [Figure 8](#)).

6.1.2.3 Brace Installation (All Airplanes)

Using [Figure 9](#) as reference, complete the following steps to temporarily install the roll servo brace.

To temporarily install the roll servo brace:

1. Place brace into position, and then secure brace to mount bracket.
2. Using crossover cable guide assembly as a guide, mark hole locations on brace.
3. Remove brace and inspect markings, making sure a 0.187" edge margin exists for fastener locations.
4. When satisfied edge margin requirement is met, place brace into position and align marks.
5. Using crossover cable guide assembly as a guide, match drill (#30) 1 hole in brace; install a temporary fastener.
6. Using crossover cable guide assembly as a guide, match drill (#30) remaining holes in brace; install temporary fasteners as you go.
7. Using mount bracket as a guide, mark 2 hole locations on brace.
8. Remove brace and inspect markings to ensure a 0.290" edge margin exists for fastener locations.
9. When satisfied edge margin requirement is met, place brace into position and align marks.
10. Using pilot holes in mount bracket as guides, drill (#10) holes in brace.
11. Install provided anchor nuts with flush-mount rivets centered on holes made in Step #10 on bottom side of brace, as shown in [Figure 9](#).

6.1.3 Permanent Roll Servo Bracketry Installation

This section provides instructions for permanently installing the roll servo base bracket and brace. The roll servo and mount bracket are a removable assembly.

To permanently install base bracket and gusset:

1. Disassemble and remove all temporarily secured brackets.
2. Deburr all holes in bracketry and fuselage skin/structure.
3. Reassemble installation with temporary fasteners in every other hole.
4. In open holes, permanently fasten bracketry with provided rivets and other hardware. Use correct hardware for application, as identified in [Table 1](#).
5. Remove temporarily fasteners from every other hole.
6. In remaining open holes, permanently fasten bracketry with provided rivets and other hardware. Use correct hardware for application, as identified in [Table 1](#).

6.2 Roll Servo Bridle Cable Preparation

This section provides instructions for preparing the roll servo bridle cable assembly for final installation. Performing these tasks after installing the roll servo bracketry, and before permanently installing the roll servo, simplifies the overall installation.



The instructions in this section assume the roll servo is still temporarily installed in airplane per procedures in Section 6.1.

6.2.1 Temporary Bridle Cable Attachment to Servo Capstan

Reference [Figure 12](#) and [Figure 24](#) when performing the following procedure.

To temporarily attach roll servo bridle cable to the servo capstan:

1. Remove capstan from servo. (See Section [8.5: Servo Capstan Removal and Re-installation](#) for instructions.)
2. Insert capstan engagement swage of bridle cable into engagement hole of capstan.
3. Starting from swage engagement hole, wrap bridle cable in each direction around capstan, as shown in [Figure 12](#).
4. Temporarily secure cable to capstan.



Temporarily securing bridle cable to the capstan with tape or a rubber band prevents the cable from unraveling when handling.

6.2.2 Temporary Servo Capstan Attachment to Servo Shaft

Reference [Figure 12](#) and [Figure 24](#) when performing the following procedure.

To temporarily attach roll servo capstan/cable assembly to the servo shaft:

1. Place capstan/cable assembly onto servo shaft. Orient capstan as shown in [Figure 13](#).



Make sure bridle cable does not make excessive contact with cable guard. The position of cable guard may need to be adjusted.

The bridle cable will prematurely wear if bridle cable and cable guard make excessive contact (i.e., the angle of the control cable is deflected when in a neutral position).

2. If bridle cable makes excessive contact with cable guard, remove guard and re-install in new position. (See Section [8.6: Cable Guard Adjustment](#) for instructions.)
3. Secure capstan/cable assembly onto servo shaft. (See Section [8.5: Servo Capstan Removal and Re-installation](#) for instructions.)

6.2.3 Temporary Bridle Cable Connection to Aileron Cable

Reference [Figure 11](#) and [Figure 12](#) when performing the following procedure.

To temporarily connect bridle cable ends to the airplane's aileron crossover cable:

1. Secure ailerons in neutral position.
2. Connect inboard and outboard cable ends to airplane's aileron crossover cable. Loosely secure to permit cable slippage.
3. Position inboard and outboard clamps so that:
 - Capstan swage engagement hole is on opposite side of capstan from control cable, as shown in [Figure 12](#).
 - Cable clamps are located at the dimensions shown in [Figure 11](#).
 - Cable clamps are positioned to best avoid contacting any structures.
4. Mark bridle cable at clamp edges oriented away from (opposite of) capstan.
5. Loosen cable clamps.
6. Remove capstan/cable assembly from servo shaft. (See Section [8.5: Servo Capstan Removal and Re-installation](#) for instructions.)

6.2.4 Fabricate Roll Servo Bridle Cable

To fabricate the roll servo bridle cable:

1. Slide a stop swage onto an end of cable.
2. Position stop swage so it is aligned with mark on cable, and so stop swage is on opposite side of mark from capstan engagement swage.
3. Use a swage compression tool to squeeze stop swage permanently onto cable.
4. Trim cable end flush with outside end of stop swage.
5. Repeat steps 1 through 5 for opposite cable end.

6.3 Pitch Servo Bracketry Installation

The pitch servo mount bracket, base bracket, and gusset mount directly to the airplane (see [Figure 23](#) for complete installation example). The mount bracket positions the base bracket and becomes fastened to the base bracket. The pitch servo gusset is fastened to base bracket and the airplane's existing structure. The mount bracket will initially be temporarily installed to locate the base bracket in the airplane. The pitch servo fastens directly to the mount bracket after the bracket is permanently installed. The pitch servo connects to the elevator control cables by bridle cables and bridle cable clamps.



Make sure all flight control cables are rigged and tensioned in accordance with the manufacturer's servicing manual.

Failure to do so may result in poor Autopilot system performance.

6.3.1 Location and Access

The pitch servo is located beneath the cabin floor between the main spar and the rear spar carry through structure on the right-hand side of the cabin as shown in [Figure 1](#).

Access requires removing the second-row seats, carpeting, and the floor in accordance with the Piper PA-34 Seneca Service Manual.

6.3.2 Airplanes Equipped with Pneumatic De-Ice Boots

If the airplane is equipped with pneumatic de-ice boots (i.e., serial numbers 34-7570001 through 34-8170092), then installers may need to reroute the pneumatic tube for the right wing de-ice boot prior to installing the pitch servo and bracketry. See [Appendix A: Pneumatic Tube Rerouting](#) for instructions.

6.3.3 Temporary Pitch Servo Bracketry Installation

This section provides instructions for temporarily installing the mount bracket, base bracket, and gusset (see [Figure 14](#)). For the mount and base brackets, different instructions are provided for airplanes with (see [Section 6.3.3.1](#)) and without (see [Section 6.3.3.2](#)) factory-installed autopilot servos. Follow the appropriate instructions for the airplane. Instructions are the same for all airplanes for the gusset installation (see [Section 6.3.3.3](#)).

6.3.3.1 Mount and Base Bracket Installation (With Factory installed Autopilot)

Complete the following steps to temporarily install the pitch servo mount bracket and base bracket in an airplane equipped with a factory autopilot pitch servo that is installed in the same general position.

To temporarily install the mount and base brackets:

1. Remove left and right air supply ducts in accordance with the Piper PA-34 Seneca Service Manual.
2. Remove existing pitch servo and its bridle cables.

3. Remove fasteners that secure existing pitch servo brackets, and then remove pitch servo brackets. The new servo brackets and gusset utilize some existing mounting holes through fuselage skin/structure.
4. If needed, remove rivets on crossover cable guide assembly (see [Figure 15](#)).
5. Temporarily secure pitch servo to mount bracket (see [Figure 16](#)).
6. Temporarily secure mount bracket to crossover cable guide assembly so that:
 - Servo capstan is centered above right-side outboard elevator control cable, as shown in [Figure 20](#).
 - Servo capstan is aligned with right outboard elevator control cable so that the bridle cables will feed onto grooves in the capstan.
 - Crossover cable guide assembly holes will maintain a minimum of 0.187" edge margin on mount bracket.
7. Using crossover cable guide assembly as a guide, match drill (#30) 1 hole through mount bracket; install a temporary fastener.
8. Using crossover cable guide assembly as a guide, match drill (#30) remaining holes through mount bracket; install temporary fasteners as you go.
9. On base bracket horizontal flange, measure, and mark rivet hole centerline. Make sure a minimum edge margin of 0.187" from center of rivet hole is maintained.
10. Temporarily secure base bracket to inboard side of mount bracket so that:
 - Base bracket maintains a clearance of ~0.01" to avoid contact with the rear spar and forward spar.
 - A minimum edge margin of 0.187" from center of rivet hole is maintained.
11. From outside of airplane, with an assistant holding base bracket in place, match drill (#30) holes through base bracket horizontal flange using existing holes in fuselage skin as a guide; install temporary fasteners as you go (see [Figure 17](#)).
12. With base bracket temporarily attached to fuselage skin and secured to mount bracket, drill (#30) holes through base bracket vertical flange using mount bracket as a guide; install temporary fasteners as you go (see [Figure 18](#)).
13. If needed, use rivets to fill unused holes in fuselage skin/structure.

6.3.3.2 Mount and Base Bracket Installation (Without Factory-installed Autopilot)

Complete the following steps to install the pitch servo mount bracket and base bracket in an airplane not equipped with a factory autopilot pitch servo.

To temporarily install the mount and base brackets:

1. Remove rivets on crossover cable guide assembly (see [Figure 15](#)).
2. Temporarily secure pitch servo to mount bracket (see [Figure 16](#)).
3. Locate and mark positions for rivet holes on base bracket horizontal flange. Ensure positions for rivet holes have an adequate edge margin of 0.187".
4. Drill 23 pilot-size holes through base bracket horizontal flange.
5. Temporarily secure mount bracket to crossover cable guide assembly so that:
 - Servo capstan is centered above right-side outboard elevator control cable.
 - Servo capstan is aligned with right outboard elevator control cable so that the bridle cables will feed onto grooves in the capstan.
 - Crossover cable guide assembly holes will maintain a minimum of 0.187" edge margin from center of hole on mount bracket.
6. Using crossover cable guide assembly as a guide, match drill (#30) 1 hole through mount bracket; install a temporary fastener.
7. Using crossover cable guide assembly as a guide, match drill (#30) remaining holes through mount bracket; install temporary fasteners as you go.
8. Temporarily secure base bracket to inboard side of mount bracket so that the following criteria is met:
 - Base bracket maintains a clearance of ~0.01" to avoid contact with rear spar and forward spar.
 - Align assembly laterally so that servo capstan maintains alignment with right outboard elevator control cable, and so that bridle cables will feed onto grooves in capstan.
9. While holding base bracket in place, drill (#30) holes through fuselage skin using base bracket horizontal flange as a guide; install temporarily fasteners as you go (see [Figure 17](#)).
10. With base bracket temporarily attached to fuselage skin and secured to mount bracket, drill (#30) holes through base bracket vertical flange using mount bracket as a guide; install temporary fasteners as you go (see [Figure 18](#)).

6.3.3.3 Gusset Installation (All Airplanes)

Using [Figure 19](#) as reference, complete the following steps to temporarily install the pitch servo gusset.

To temporarily install the gusset:

1. Remove temporary fasteners from 3-4 aft holes on base bracket horizontal flange.
2. If there *is* an existing hole and fastener in pulley mounting bracket at FS 128, then remove fastener.
3. If there *is not* an existing hole and fastener in pulley mounting bracket at FS 128, then complete the following:
 - A. Using [Figure 19](#) as a guide, mark location roughly centered between gusset and bracket while maintaining a minimum 0.241" edge margin on both parts and a minimum 0.290" edge margin with pulley bolt hole.
 - B. Drill pilot-size hole through pulley mounting bracket at location marked in Step A.
 - C. Drill (#20) hole through pulley mounting bracket using pilot hole as a guide.
4. Locate gusset into position so that the following criteria is met:
 - Gusset horizontal flange holes maintain a minimum edge margin of 0.187" from center of hole.
 - Pulley mounting bracket hole maintains a minimum edge margin of 0.241" from center of hole.
 - Gusset vertical flange rests against right outboard pulley bracket.
5. While holding gusset in place, match drill (#20) hole through gusset using hole in pulley mounting bracket as a guide; temporarily secure with provided hardware.
6. While holding gusset in place, match drill (#30) holes through gusset using holes in base bracket horizontal flange as a guide; install temporary fasteners as you go.

6.3.4 Permanent Pitch Servo Bracketry Installation

This section provides instructions for permanently installing the mount bracket, base bracket, and gusset.

To complete pitch servo bracketry installation:

1. Disassemble and remove all temporarily secured bracketry.
2. Deburr all holes in bracketry and fuselage skin/structure.
3. Reassemble installation with temporary fasteners in every other hole.
4. In open holes, permanently fasten bracketry with provided rivets and other hardware. Use correct hardware for application, as identified in [Table 2](#).
5. Remove temporarily fasteners from every other hole.
6. In remaining open holes, permanently fasten bracketry with provided rivets and other hardware. Use correct hardware for application, as identified in [Table 2](#).
7. Fasten gusset to pulley mounting bracket with provided hardware (see [Figure 19](#)).

6.4 Pitch Servo Bridle Cable Preparation

This section provides instructions for preparing the roll servo bridle cable assembly for final installation. Performing these tasks after installing the roll servo bracketry, and before permanently installing the roll servo, simplifies the overall installation.



The instructions in this section assume the pitch servo is still temporarily installed in airplane per procedures in Section 6.3.

6.4.1 Temporary Bridle Cable Attachment to Servo Capstan

Reference [Figure 22](#) and [Figure 24](#) when performing the following procedure.

To attach pitch servo bridle cable to the servo capstan:

1. Remove capstan from servo. (See Section 8.5: [Servo Capstan Removal and Re-installation](#) for instructions.)
2. Insert capstan engagement swage of bridle cable into engagement hole of capstan.
3. Starting from swage engagement hole, wrap bridle cable in each direction around capstan, as shown in [Figure 22](#).
4. Temporarily secure cable to capstan.



Temporarily securing bridle cable to the capstan with tape or a rubber band prevents the cable from unraveling when handling.

6.4.2 Temporary Servo Capstan Attachment to Servo Shaft

Reference [Figure 22](#) and [Figure 24](#) when performing the following procedure.

To temporarily attach pitch servo capstan/cable assembly to the servo shaft:

1. Place capstan/cable assembly onto servo shaft, making sure head of shear screw engages with hole in capstan. Orient capstan as shown in [Figure 23](#).



Make sure bridle cable does not make excessive contact with cable guard. The position of cable guard may need to be adjusted.

The bridle cable will prematurely wear if bridle cable and cable guard make excessive contact (i.e., the angle of the control cable is deflected when in a neutral position).

2. If bridle cable makes excessive contact with bridle guard, remove guard and re-install in new position. (See Section 8.6: [Cable Guard Adjustment](#) for instructions.)
3. Secure capstan/cable assembly onto servo shaft. (See Section 8.5: [Servo Capstan Removal and Re-installation](#) for instructions.)

6.4.3 Temporary Bridle Cable Connection to Elevator Cable

Reference [Figure 21](#) when performing the following procedure.

To temporarily connect bridle cable ends to the airplane's elevator cable:

1. Secure elevator in neutral position.
2. Connect inboard and outboard cable ends to airplane's elevator "up" cable. Loosely secure to permit cable slippage.
3. Position inboard and outboard clamps so that:
 - Capstan swage engagement hole is on opposite side of capstan from control cable.
 - Cable clamps are located at the dimensions shown in [Figure 21](#).
 - Cable clamps are positioned to best avoid contacting any structures.
4. Mark bridle cable at clamp edges oriented away from (opposite of) capstan.
5. Loosen cable clamps.
6. Remove capstan/cable assembly from servo shaft. (See Section [8.6: Cable Guard Adjustment](#) for instructions.)

6.4.4 Fabricate Pitch Servo Bridle Cable

To fabricate the pitch servo bridle cable:

1. Slide a stop swage onto an end of cable.
2. Position stop swage aligned with mark on cable, so stop swage is on opposite side of mark from capstan engagement swage.
3. Use a swage compression tool to squeeze stop swage permanently onto cable.
4. Trim cable end flush with outside end of stop swage.
5. Repeat steps 1 through 5 for opposite cable end.

7 Servo Electrical Wiring

For complete wiring and network configuration instructions, refer to the following documents at dynoncertified.com/docs:

- *103261-000 SkyView HDX System General Installation Manual*
- *103947-000 SkyView HDX Wiring Diagram - Twin Engine*

Route the servo electrical harnesses through the airframe structure as appropriate. Take precautions to prevent the servo harnesses from chafing against structure or interfering with the airplane's flight controls or other moving components.



Servo power and Autopilot Disconnect circuits are required to be separate from the signal and power circuits provided over the SkyView Network. The servos should receive power from a common power source with circuit protection sized for the loads associated with all servos.

Terminate the servo network electrical harnesses with a D9 connector shell with female pins.

Terminate the servo electrical harness pigtails with the mating D9 connector.

Dynon provides the SV-NET-SERVO Network Autopilot Servo Cable Kit to aid in wiring the servos. Contact Dynon Sales for more information.



Power for all servos must be controlled by a switch prominently mounted on the instrument panel. This provides the pilot the ability to quickly turn off power to the servos should it be needed.

8 Servo Maintenance

This section provides information and procedures to maintain the roll and pitch servos. It serves as instructions for Continued Airworthiness.

8.1 Roll Servo Removal and Installation

8.1.1 Location and Access

The roll servo is located beneath the cabin floor between the main spar and the rear spar carry-through structures on the left-hand side of the cabin as indicated in [Figure 1](#).

Access requires removing the seats, carpeting, and the floor in accordance with the manufacturers service instructions.

8.1.2 Roll Servo Removal

To remove the roll servo:

1. Remove left and right air supply ducts in accordance with the Piper PA-34 Seneca Service Manual.
2. Disconnect D9 electrical harness connector from servo.
3. Loosen bridle cable clamps from aileron control cables. Mark location of cable clamps for ease of re-installation.
4. Remove fasteners securing mount bracket to base bracket (see [Figure 5](#)) and retain for re-installation.
5. Remove mount bracket with roll servo from airplane.
6. Remove safety wire and unfasten hardware securing roll servo to mount bracket (see [Figure 4](#)).
7. Remove roll servo from mount bracket.

8.1.3 Roll Servo Installation

To install the roll servo:

1. Fasten roll servo to mount bracket with provided/retained hardware (see [Figure 4](#)). Torque fasteners to 25–30 in-lbs. Use correct hardware for application, as identified in [Table 1](#).
2. Safety wire bolts to prevent them from loosening. There are safety wire holes in mount bracket.
3. Place roll servo/mount bracket assembly against base bracket and on top of roll servo brace, as shown in [Figure 5](#) and [Figure 9](#).
4. Fasten roll servo/mount bracket assembly to base bracket with provided/retained hardware (see [Figure 5](#)). Torque fasteners to 25–30 in-lbs. Use correct hardware for application, as identified in [Table 1](#).

5. Safety wire bolts to prevent them from loosening.



Installers can safety wire bolts together (see [Figure 13](#)), to the mount bracket using provided holes in bracket, or a combination thereof, depending on preferred method and access.

6. Connect D9 electrical harness connector to roll servo.



Use a clamp or other fastener to secure harness cable to avoid entanglement with moving components. See [Figure 13](#) for an example.

8.1.4 Roll Servo Bridle Cable Installation



Make sure all flight control cables are rigged and tensioned in accordance with the manufacturer's servicing manual.

Failure to do so may result in poor Autopilot system performance.

To install the roll servo bridle cable:

1. Secure ailerons in neutral position.
2. Remove capstan from servo. (See [Section 8.5: Servo Capstan Removal and Re-installation](#) for instructions.)



The shear screw does not need to be removed to remove the capstan. The capstan has a hole that fits over the shear screw head.

3. Insert capstan engagement swage of bridle cable into engagement hole of capstan (see [Figure 12](#)).
4. Starting from swage engagement hole, wrap bridle cable in each direction around capstan, as shown in [Figure 12](#).
5. Temporarily secure cable to capstan.



Temporarily securing bridle cable to the capstan with tape or a rubber band prevents the cable from unraveling when handling.

6. Place capstan/cable assembly onto servo shaft, making sure head of shear screw engages with hole in capstan. Orient capstan as shown in [Figure 13](#).



Make sure bridle cable does not make excessive contact with cable guard. The position of cable guard may need to be adjusted.

The bridle cable will prematurely wear if bridle cable and cable guard make excessive contact (i.e., the angle of the control cable is deflected when in a neutral position).

7. If bridle cable makes excessive contact with bridle guard, remove guard and re-install in new position. (See [Section 8.6: Cable Guard Adjustment](#) for instructions.)

8. Secure capstan/cable assembly onto servo shaft. (See Section [8.5: Servo Capstan Removal and Re-installation](#) for instructions.)
9. Make sure control cable where bridle cable clamps will attach is clean and free of dirt and grease.
10. Connect inboard and outboard cable ends to airplane's aileron crossover cable (see [Figure 11](#)). Temporarily secure to permit cable slippage.
11. Position inboard and outboard cable clamps so that:
 - Clamps contact stop swages.
 - Clamps are located at the dimensions shown in [Figure 11](#).
 - Clamps are positioned to best avoid contacting any structures.
12. Tighten inboard cable clamp fasteners.
13. Push or pull outboard cable clamps outboard, applying 12-15 lbs. of tension to bridle cable.
14. Tighten outboard cable clamp fasteners to maintain tension.
15. Torque all cable clamp fasteners to 35-40 in-lbs.
16. Using a feeler gauge, measure gap between clamp halves (top and bottom) of each clamp assembly. Make sure gaps meet the following criteria:
 - Top and bottom clamp gap measurements are close (i.e., clamps halves are close to parallel to one another).
 - Clamp gap measurements are not less than 0.003".



If clamp gap measurements do not meet criteria above, measure diameter of control cable, and then contact Dynon Technical Support for a resolution.

Out-of-specification clamps can slip under load, causing the bridle cable to loosen and come off the capstan.

To check the bridle cable installation:

1. Remove tape temporarily securing bridle cable to capstan.
2. Remove device securing flight controls in neutral position.
3. While moving control through full range of motion, verify the following:
 - Cable clamps do not contact any structures during entire travel.
 - Capstan never rotates more than 150 degrees in either direction from neutral.
4. Cycle control several times, return it to neutral, and verify the following:
 - Position of cable clamps closely match the dimensions shown in [Figure 11](#).
 - Capstan swage engagement hole is positioned as shown in [Figure 13](#).
 - Bridle cable tension has not changed.



When all autopilot servos have been installed, perform the Servo Calibration procedure. (See Section [8.3](#) for instructions.) The autopilot system will not function until calibration is performed.

8.2 Pitch Servo Removal and Installation

8.2.1 Location and Access

The pitch servo is located beneath the cabin floor between the main spar and the rear spar carry through structure on the right-hand side of the cabin as shown in [Figure 1](#).

Access requires removing the seats, carpeting, and the floor in accordance with the manufacturers service instructions.

8.2.2 Pitch Servo Removal

To remove the pitch servo:

1. Remove left and right air supply ducts in accordance with the Piper PA-34 Seneca Service Manual.
2. Disconnect D9 harness connector from pitch servo.
3. Loosen bridle cable clamps from elevator control cables. It is recommended that you mark location of cable clamps for ease of re-installation.
4. Remove safety wire and unfasten hardware securing pitch servo to mount bracket (see [Figure 16](#)).
5. Remove pitch servo by moving it outboard and clear of mount bracket.

8.2.3 Pitch Servo Installation

To install the pitch servo:

1. Fasten pitch servo to mount bracket with provided/retained hardware (see [Figure 16](#)). Torque fasteners to 25–30 in-lbs. Use correct hardware for application, as identified in [Table 1](#).
2. Safety wire bolts to prevent them from loosening.



Installers can safety wire bolts together (see [Figure 23](#)), to the mount bracket using provided holes in bracket, or a combination thereof, depending on preferred method and access.

3. Connect D9 electrical harness connector to pitch servo.



Use a clamp or other fastener to secure harness cable to avoid entanglement with moving components. See [Figure 23](#) for an example.

8.2.4 Pitch Servo Bridle Cable Installation



Make sure all flight control cables are rigged and tensioned in accordance with the manufacturer's servicing manual.

Failure to do so may result in poor Autopilot system performance.

To install pitch servo bridle cable:

1. Secure elevator in neutral position.
2. Remove capstan from servo. (See Section [8.5: Servo Capstan Removal and Re-installation](#) for instructions.)



The shear screw does not need to be removed to remove the capstan. The capstan has a hole that fits over the shear screw head.

3. Insert capstan engagement swage of bridle cable into engagement hole of capstan (see [Figure 22](#)).
4. Starting from swage engagement hole, wrap bridle cable in each direction around capstan, as shown in [Figure 22](#).
5. Temporarily secure cable to capstan.



Temporarily securing bridle cable to the capstan with tape or a rubber band prevents the cable from unraveling when handling.

6. Place capstan/cable assembly onto servo shaft, making sure head of shear screw engages with hole in capstan (see [Figure 21](#) and [Figure 24](#)).



Make sure bridle cable does not make excessive contact with cable guard. The position of cable guard may need to be adjusted.

The bridle cable will prematurely wear if bridle cable and cable guard make excessive contact (i.e., the angle of the control cable is deflected when in a neutral position.)

7. If cable guard interferes with the bridle cable, remove cable guard and re-attach in new position. (See [8.6: Cable Guard Adjustment](#) for instructions.)
8. Secure capstan/cable assembly onto servo shaft. (See Section [8.5: Servo Capstan Removal and Re-installation](#) for instructions.)
9. Make sure control cable where bridle cable clamps will attach is clean and free of dirt and grease.
10. Connect forward and aft cable ends to airplane's elevator "up" cable (see [Figure 21](#)). Loosely secure to permit cable slippage.
11. Position inboard and outboard clamps so that:
 - Cable clamps contact the stop swage.

- Cable clamps are located at the dimensions shown in [Figure 21](#).
 - Cable clamps are positioned to best avoid contacting any structures.
12. Tighten aft cable clamp fasteners.
 13. Push or pull forward cable clamps outboard, applying 12-15 lbs. of tension to bridle cable.
 14. Tighten forward cable clamp fasteners to maintain tension.
 15. Torque all cable clamp fasteners to 35-40 in-lbs.
 16. Using a feeler gauge, measure gap between clamp halves (top and bottom) of each clamp assembly. Make sure gaps meet the following criteria:
 - Top and bottom clamp gap measurements are close (i.e., clamps halves are close to parallel to one another).
 - Clamp gap measurements are not less than 0.003".



If clamp gap measurements do not meet criteria above, measure diameter of control cable, and then contact Dynon Technical Support for a resolution.

Out-of-specification clamps can slip under load, causing the bridle cable to loosen and come off the capstan.

To check the bridle cable installation:

1. Remove device securing flight controls in neutral position.
2. Remove tape temporarily securing the bridle cable to capstan.
3. While moving control through its full range of motion, verify the following:
 - Cable clamps do not contact any structures during entire travel.
 - Capstan never rotates more than 150 degrees in either direction from neutral.
4. Cycle control several times, return it to neutral, and verify the following:
 - Position of cable clamps closely match dimensions shown in [Figure 19](#).
 - Capstan swage engagement hole is positioned as shown in [Figure 23](#).
 - The bridle cable tension has not changed.



When all autopilot servos have been installed, perform the Servo Calibration procedure. (See Section [8.3](#) for instructions.) The autopilot system will not function until calibration is performed.

8.3 Servo Calibration Procedure

The SkyView HDX Autopilot servo settings are available for download as a configuration file that is loaded into the SkyView HDX display. This file configures the autopilot servo performance settings to meet the applicable certification regulations. Servo calibration cannot be performed without the following:

- An ADAHRS module (SV-ADAHRS-200) installed and configured in the SkyView network.
- All servos installed and configured in the SkyView network.
- V-speeds correctly entered in SkyView HDX. (See the *103261-000 SkyView HDX System Installation Manual* document for instructions.)

To make a new servo appear on the SkyView HDX display, configure the SkyView network (SYSTEM SETUP > NETWORK SETUP > CONFIGURE). (See the *103261-000 SkyView HDX System Installation Manual* document for instructions.)

To calibrate the servos, enter the Servo Calibration Wizard (SETUP MENU > HARDWARE CALIBRATION > AP SERVO CALIBRATION > CALIBRATION) and follow the onscreen instructions to calibrate the servo(s).

SkyView HDX checks the status of the AP Disengage Button. If SkyView HDX detects that the button is pressed (the input is grounded) upon entering AP SERVO CALIBRATION, the AP Disengage Button is assumed to be stuck (or incorrectly installed), resulting in the following message being displayed, and the Autopilot servo calibration is aborted:

"The servo disconnect switch appears to be pressed and may be installed incorrectly. The servo disconnect switch should be a type Momentary, Push Button Normal Open (PBNO). Press cancel below to return to the servo calibration menu."

If the servo calibration procedure is not successful, inspect the button and servo wiring. (See the *103261-000 SkyView HDX System Installation Manual* document for instructions.) If button type and wiring is correct, call Dynon Technical Support.

If the servo calibration procedure is successful, SkyView HDX will automatically instruct you to run the servo test procedure. (See Section [8.4](#) for instructions.)

8.4 Servo Test Procedure

The servo test procedure requires a successful servo calibration. The servo test procedure verifies that each servo is configured properly by moving the control surfaces while the installer verifies the correct movement. You may run this procedure on its own at any time after a successful servo calibration. SkyView HDX will not display AP status on the Top Bar until after this test procedure is successfully completed.

To run this procedure on its own (after a successful servo calibration procedure), enter the Servo Test Wizard (SETUP MENU > HARDWARE CALIBRATION > AP SERVO CALIBRATION > TEST) and follow the onscreen instructions to test the servo(s).

8.5 Servo Capstan Removal and Re-installation

A servo comes equipped with a capstan installed; however, the capstan will need to be removed during servo installation and maintenance procedures. The following procedure details the task of removing and then re-installing a capstan.

Reference [Figure 24](#) when performing the following procedure.

1. Remove cotter pin that secures castle nut to servo shaft.
2. Make mating marks on castle nut and servo shaft, and then remove castle nut from servo shaft.
3. Remove 5/16" wave washer from servo shaft.
4. Removed 5/16" nylon washer from servo shaft.
5. Remove capstan from servo shaft.



The shear screw does not need to be removed to remove the capstan. The capstan has a hole that fits over the shear screw head.



If the shear screw is loosened, it must be completely removed. The shear screw must be re-installed with a new application of Red Loctite™ 271 thread-locking compound, and finger-tightened until head is fully seated against servo attachment disc.

6. Re-install capstan onto output shaft, aligning hole in capstan with brass shear screw located in output shaft collar.
7. Re-install 5/16" nylon washer on servo shaft.
8. Re-install 5/16" wave washer on servo shaft.
9. Finger-tighten castle nut onto servo shaft, and then use a wrench to tighten until slot in castle nut lines up with hole for cotter pin in servo shaft.



DO NOT overtighten the castle nut!

Tightening the castle nut beyond 4 in-lbs. of torque may prevent the capstan from separating from the servo shaft if the controls become jammed.

10. Install new cotter pin to secure castle nut to servo shaft.

8.6 Cable Guard Adjustment

Servos come equipped with a cable guard installed. The cable guard may need to be repositioned to avoid interference with the flight control cables or the bridle cables during servo installation procedures. The following procedure details the task of adjusting a cable guard.

Reference [Figure 24](#) when performing the following procedure.

To remove the capstan and adjust the cable guard:

1. Remove capstan from servo shaft. (See Section [8.5](#) for instructions.)
2. Remove (4) #6-32 screws and (4) #6 star washers that secure capstan guard to servo.
3. Rotate capstan guard to correct position.
4. Re-install (4) #6-32 screws and (4) #6 star washers that secure capstan guard to servo.
5. Re-install capstan onto servo shaft. (See Section [8.5](#) for instructions.)

8.7 Servo Shear Screw Replacement

Dynon servos come equipped with a capstan. The capstan connects to the servo via a frangible shear screw. The shear screw can be broken by the pilot to restore system movement should a servo become jammed. It is possible for turbulence loads acting on the airplane to cause a shear screw to fail, even though the servo never jammed.

In the event of a shear screw failure, contact Dynon Avionics Technical Support to request a 102991-000 Shear Screw Replacement Kit. See the *103000-000 Dynon Servo Shear Screw Replacement Instructions* document included in the Shear Screw Replacement Kit. Approximately

9 Figures

9.1 Servo Locations and Access

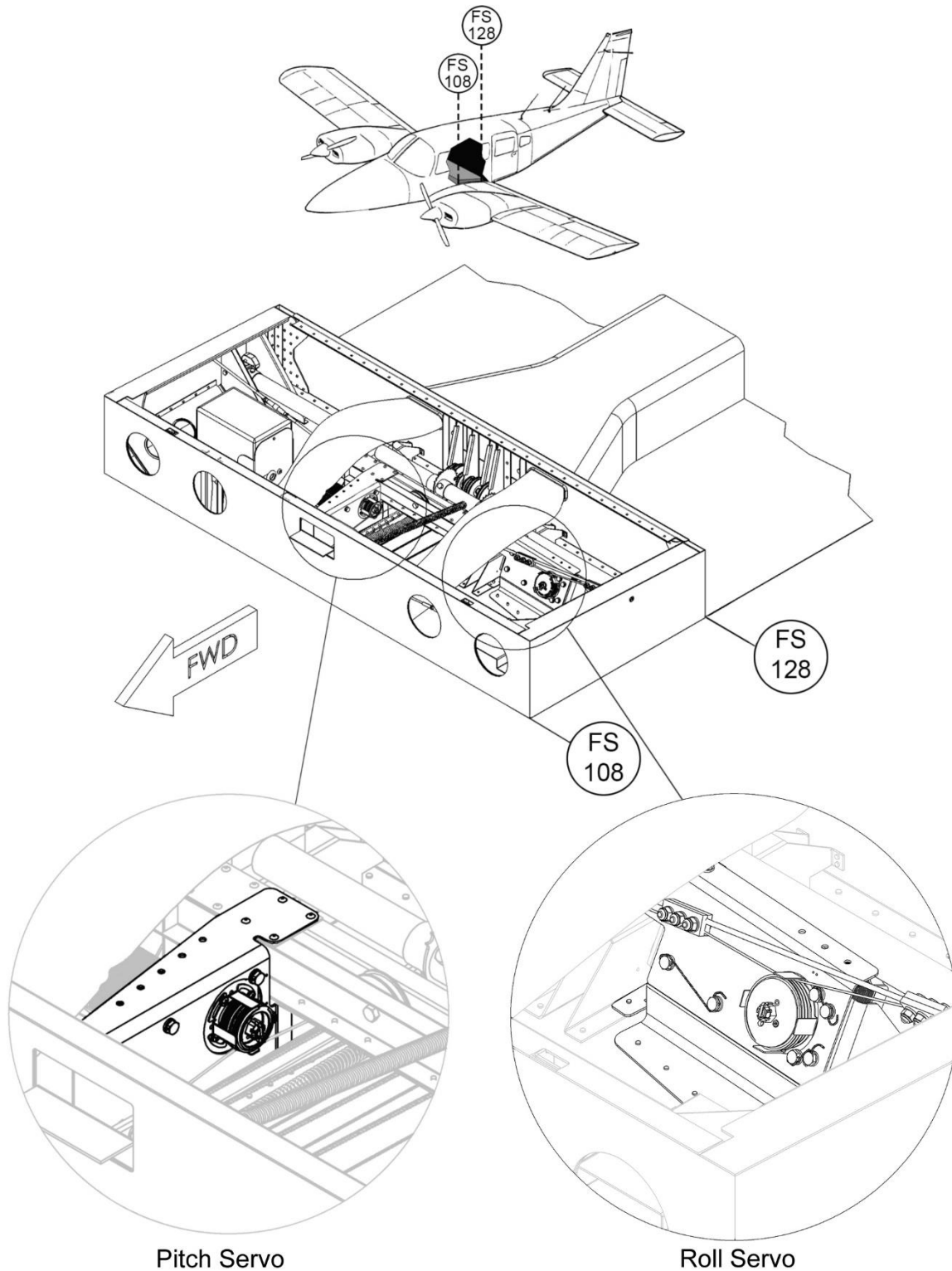

Figure 1: Pitch and Roll Servo Locations

9.2 Roll Servo Parts, Assemblies, and Installation

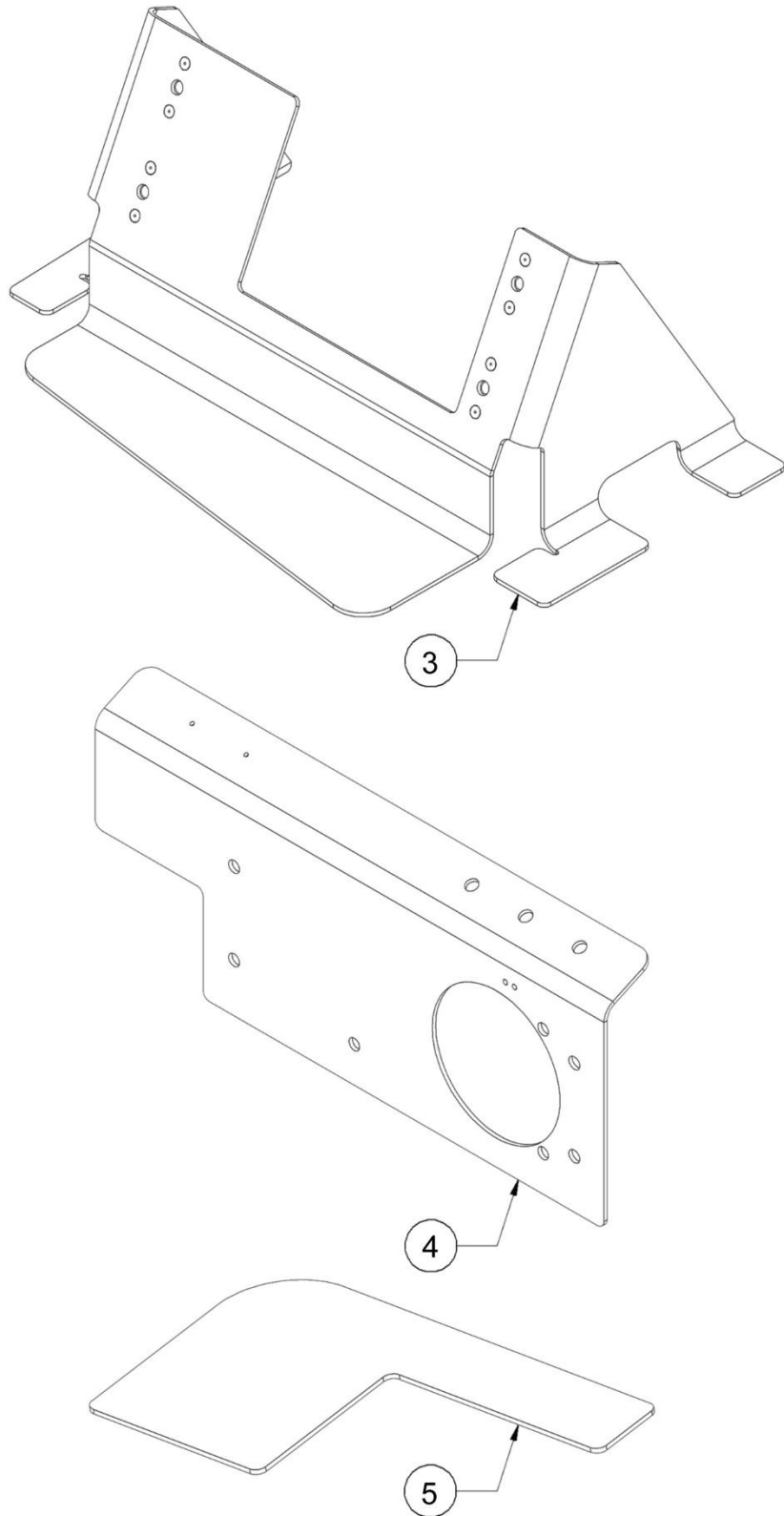

Figure 2: Roll Servo Bracketry

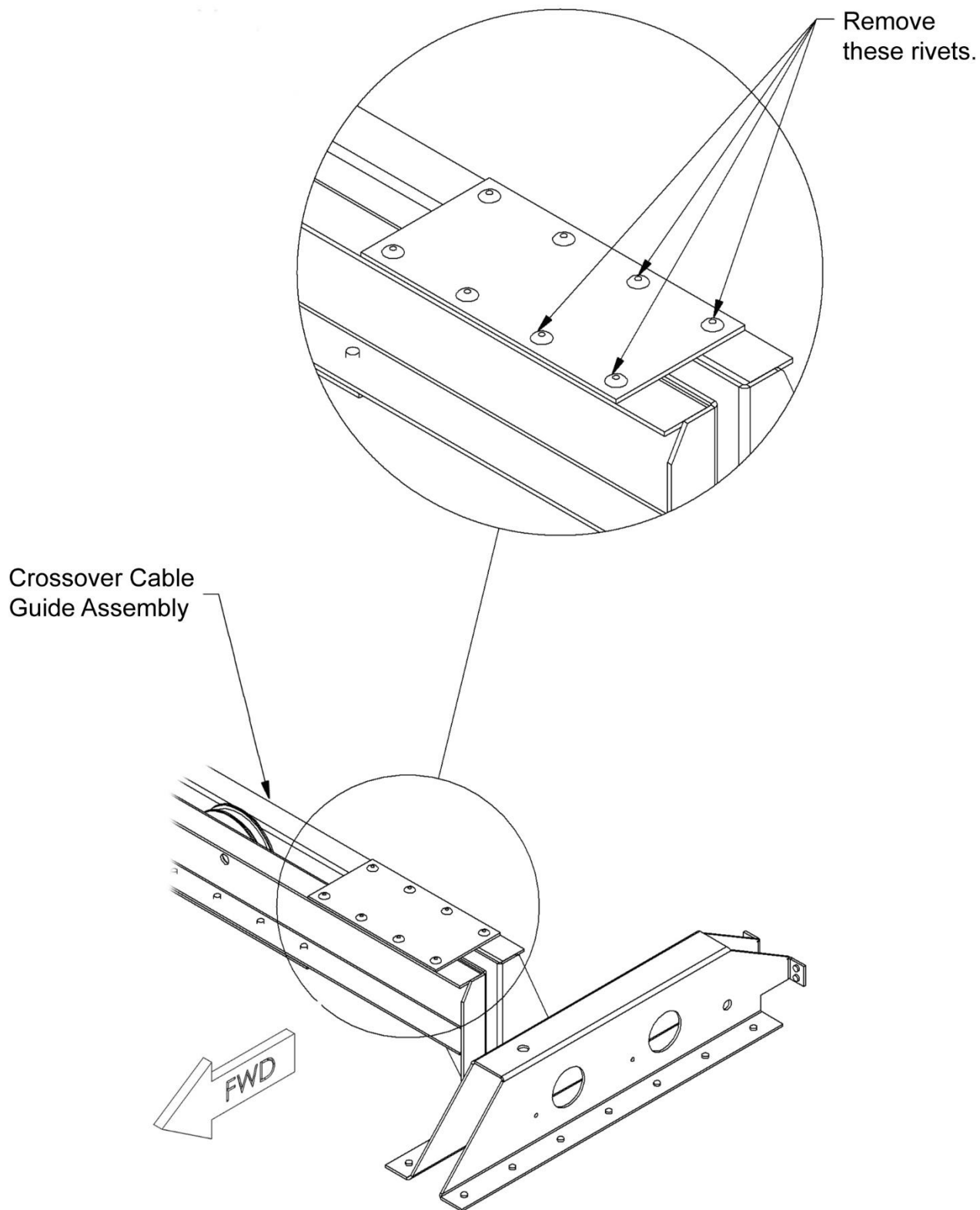

Figure 3: Roll Servo Install Preparation

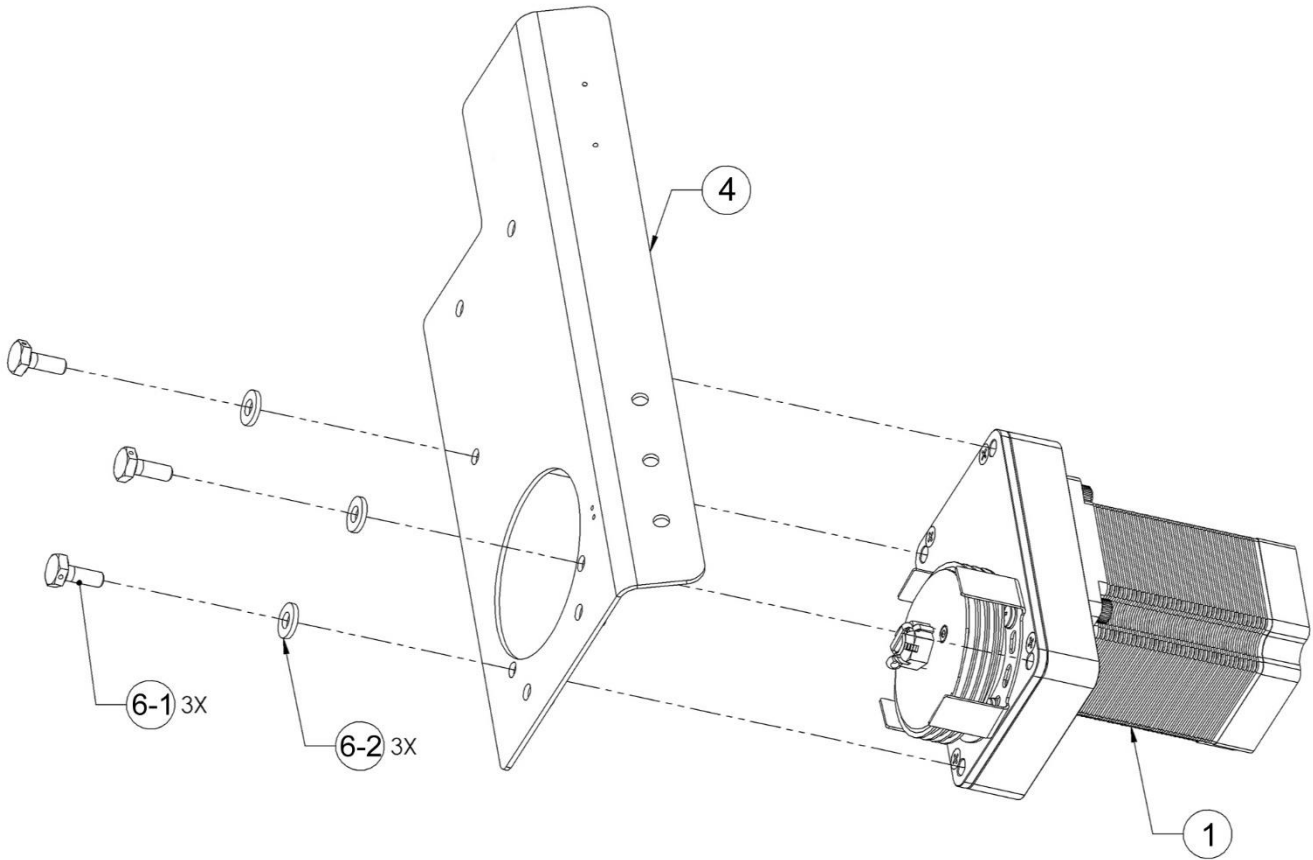

Figure 4: Roll Servo Mount Bracket Assembly

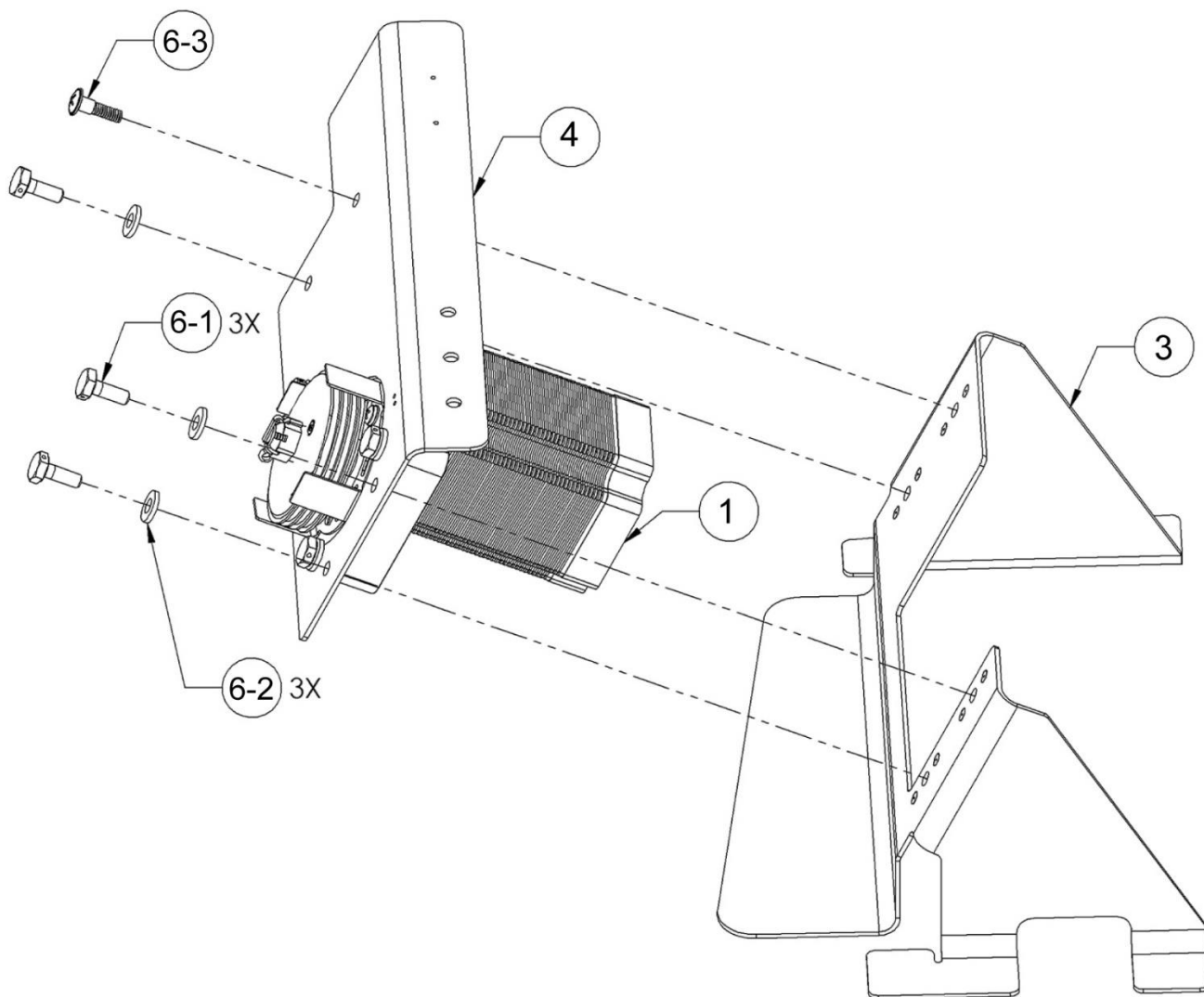

Figure 5: Roll Servo Base and Mount Assembly

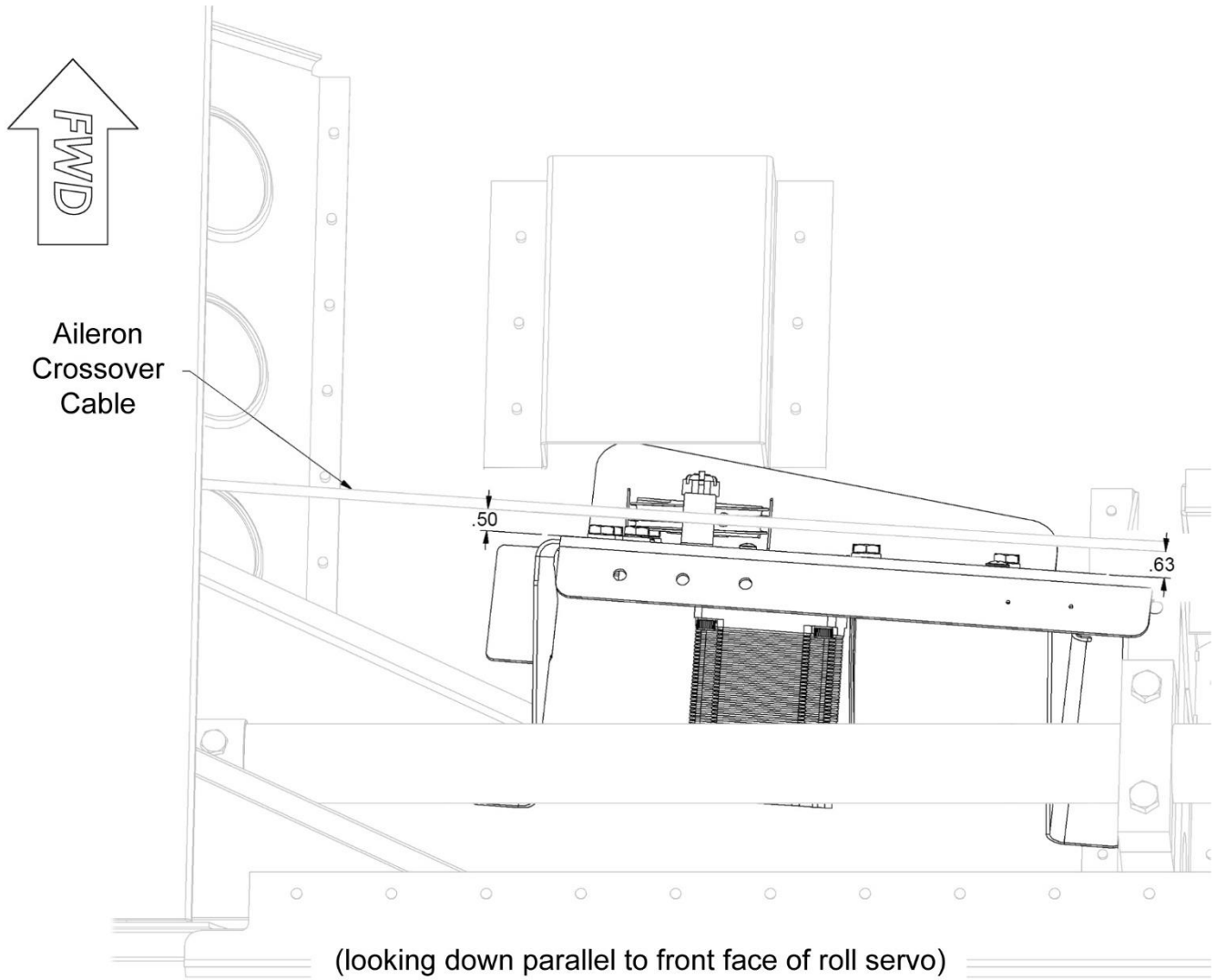

Figure 6: Roll Servo Base and Mount Bracket Assembly Alignment

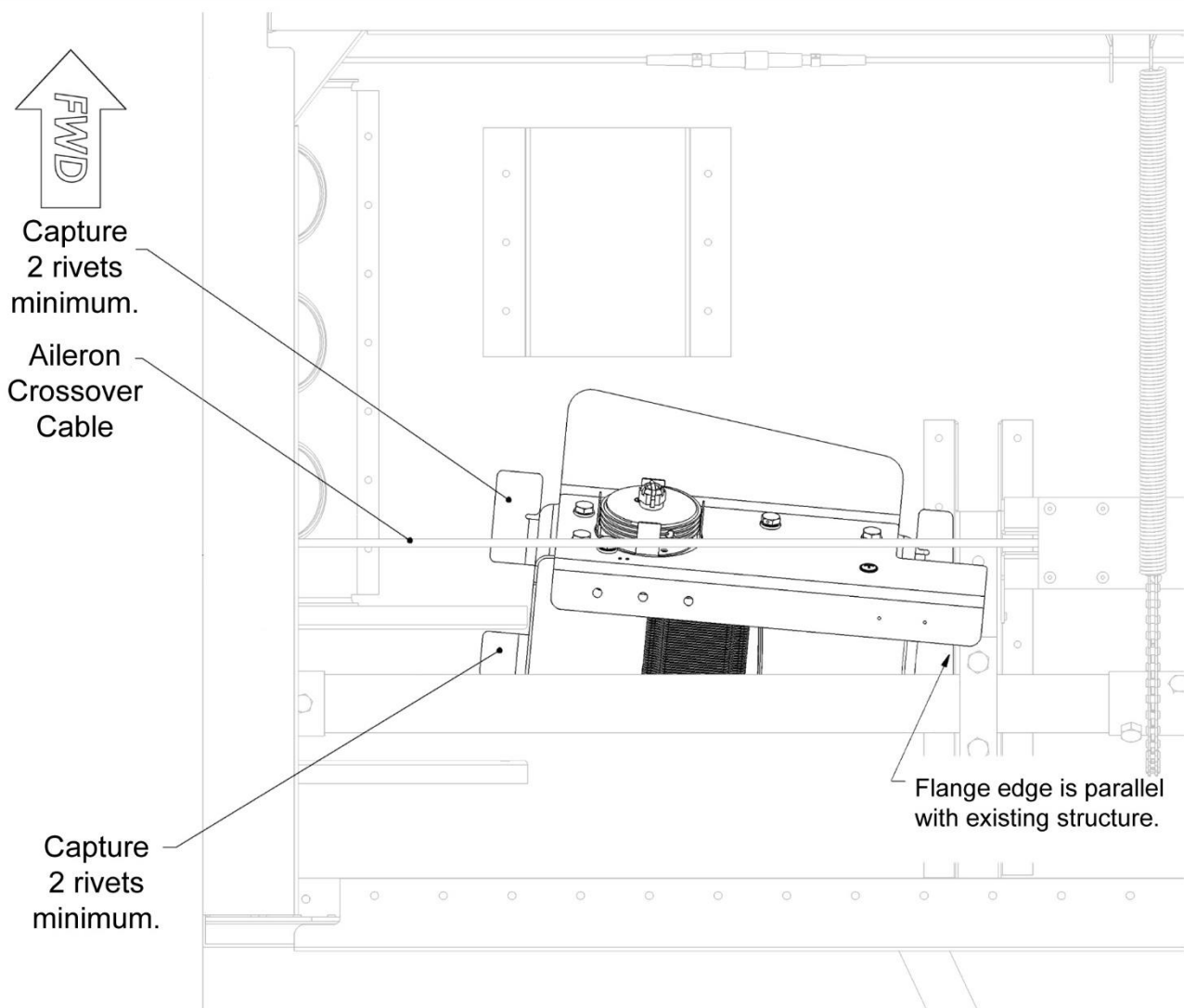

Figure 7: Roll Servo Base and Mount Bracket Fastener Attachment Considerations

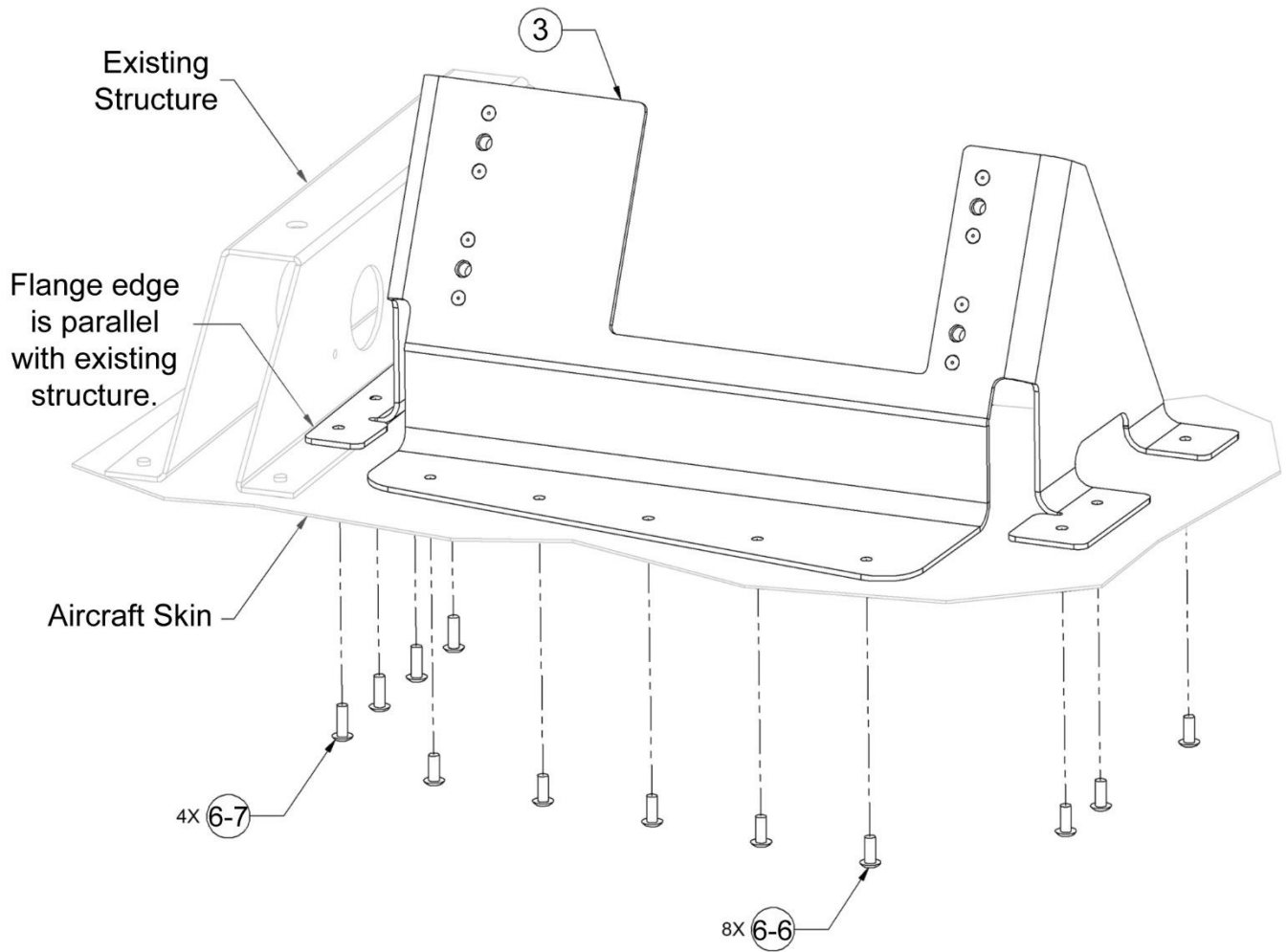

Figure 8: Roll Servo Base Bracket Installation

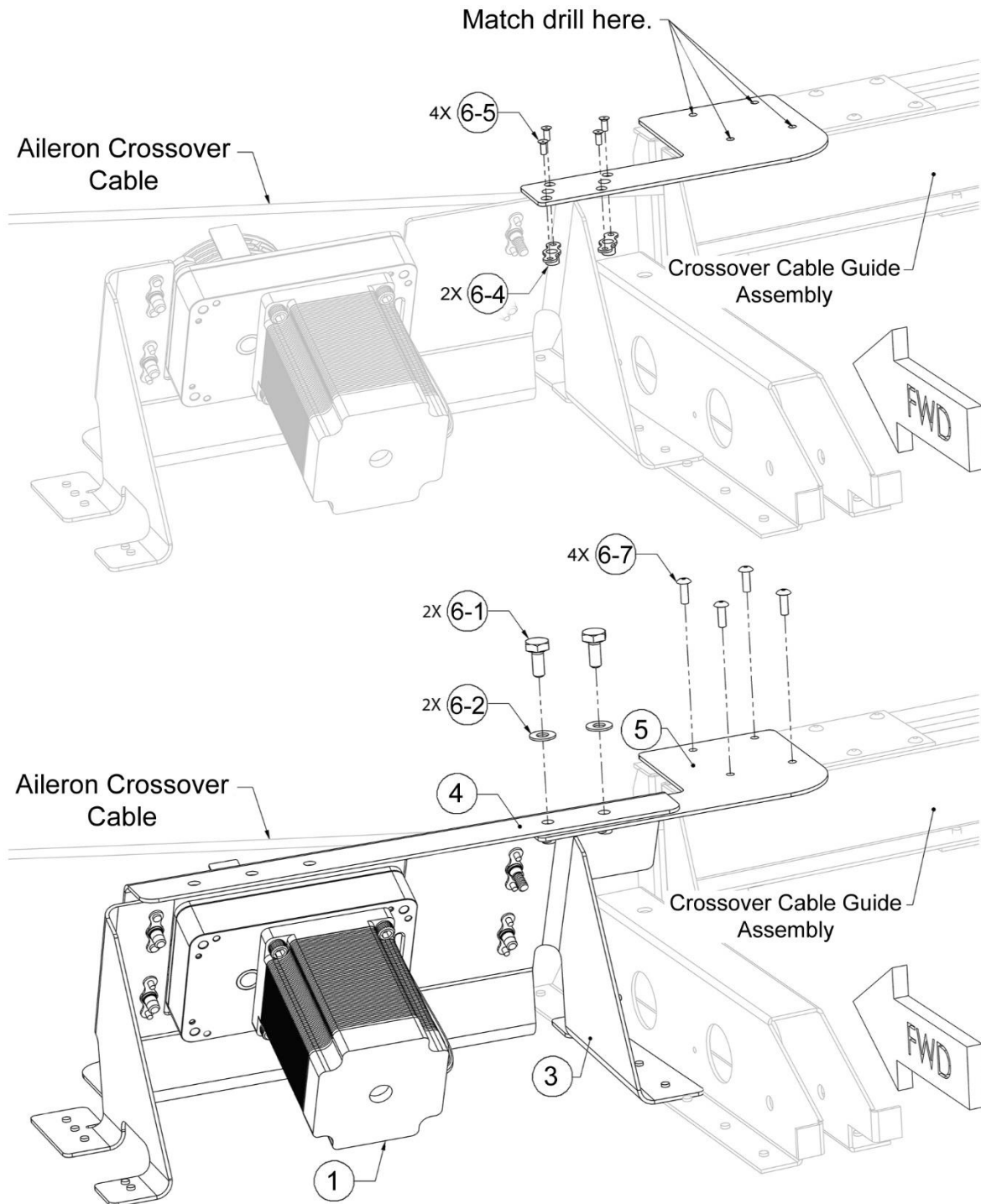

Figure 9: Roll Servo Brace Installation

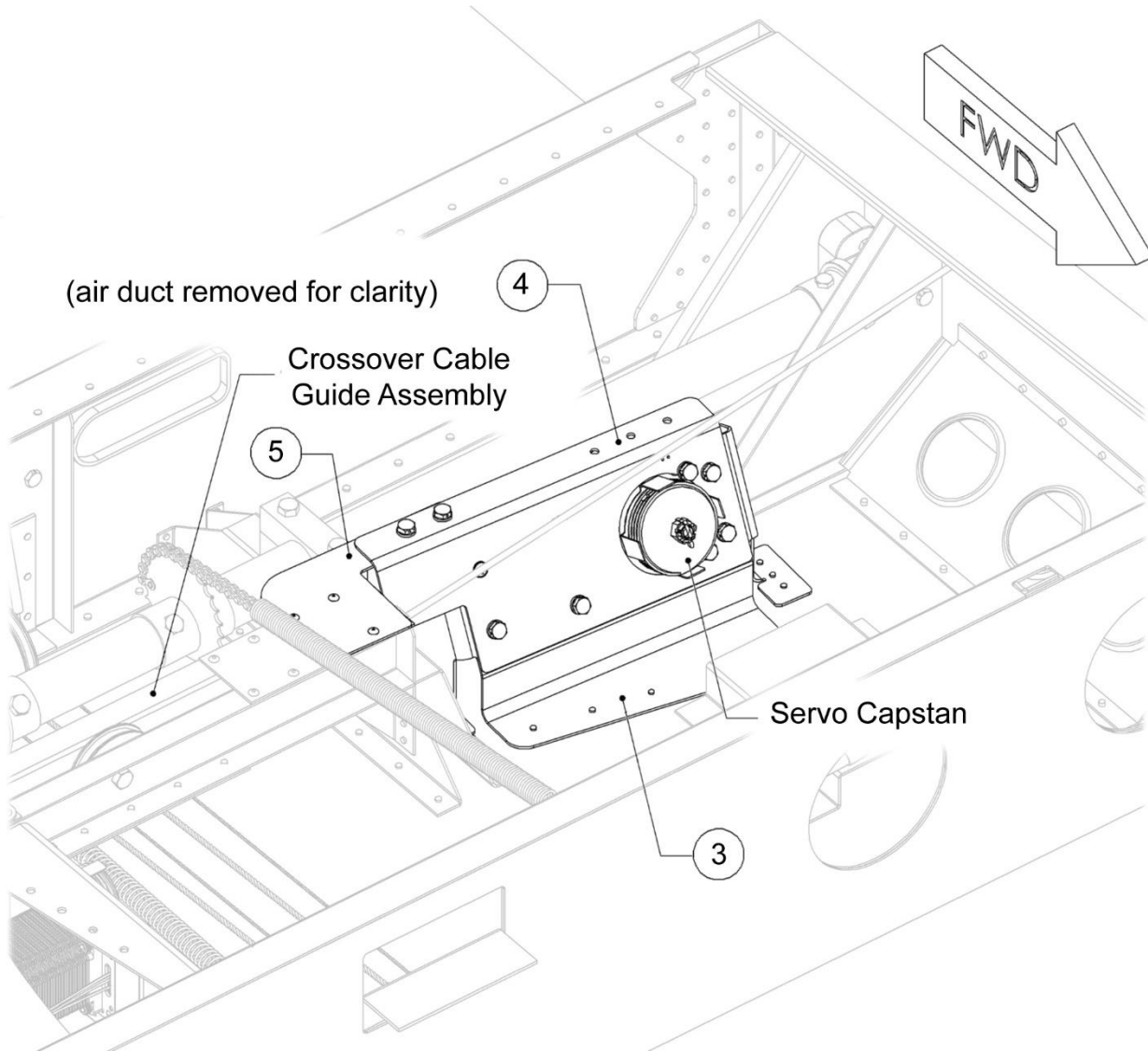

Figure 10: Roll Servo Bracketry Installed

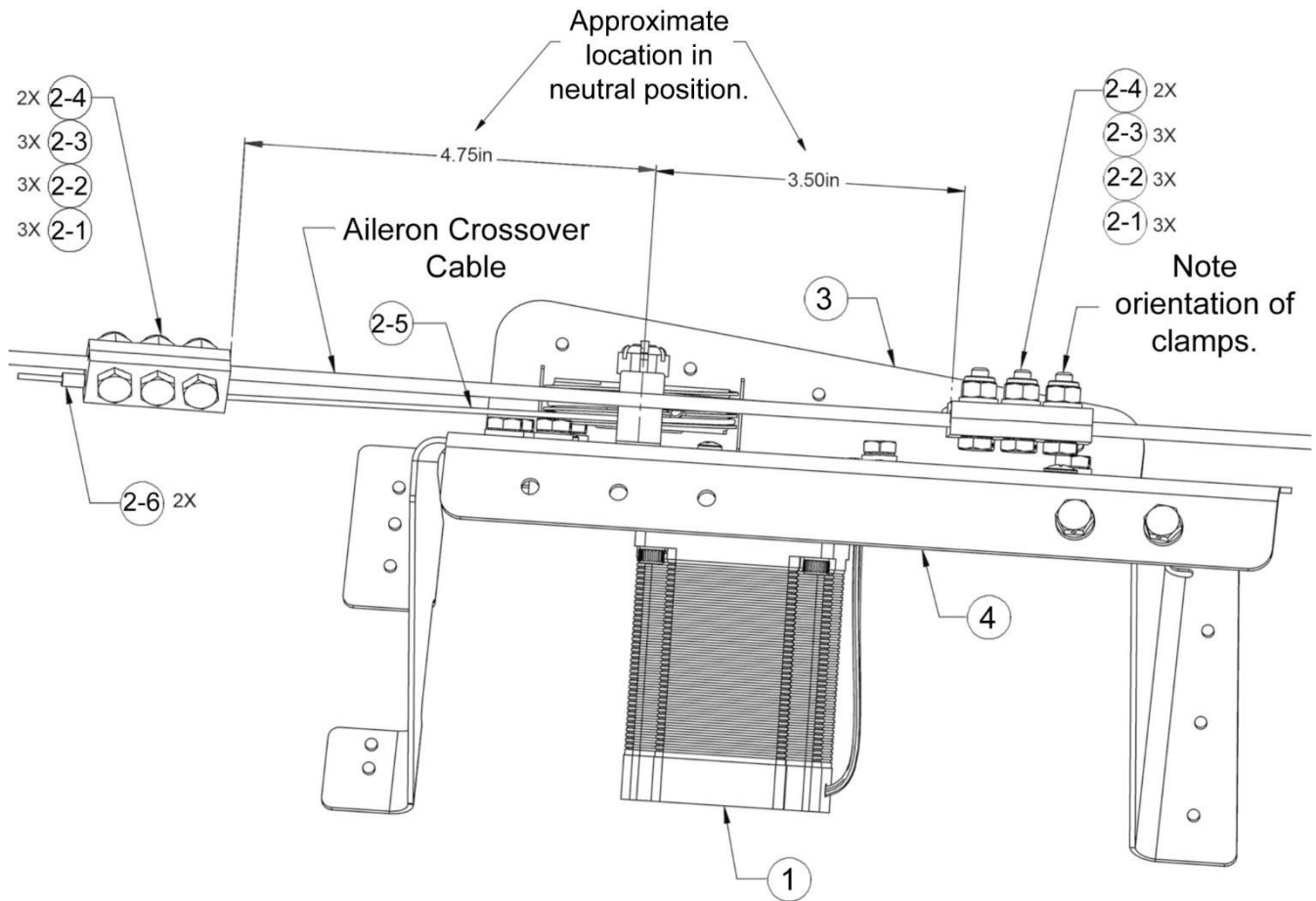

Figure 11: Roll Servo Bridle Clamp Installation

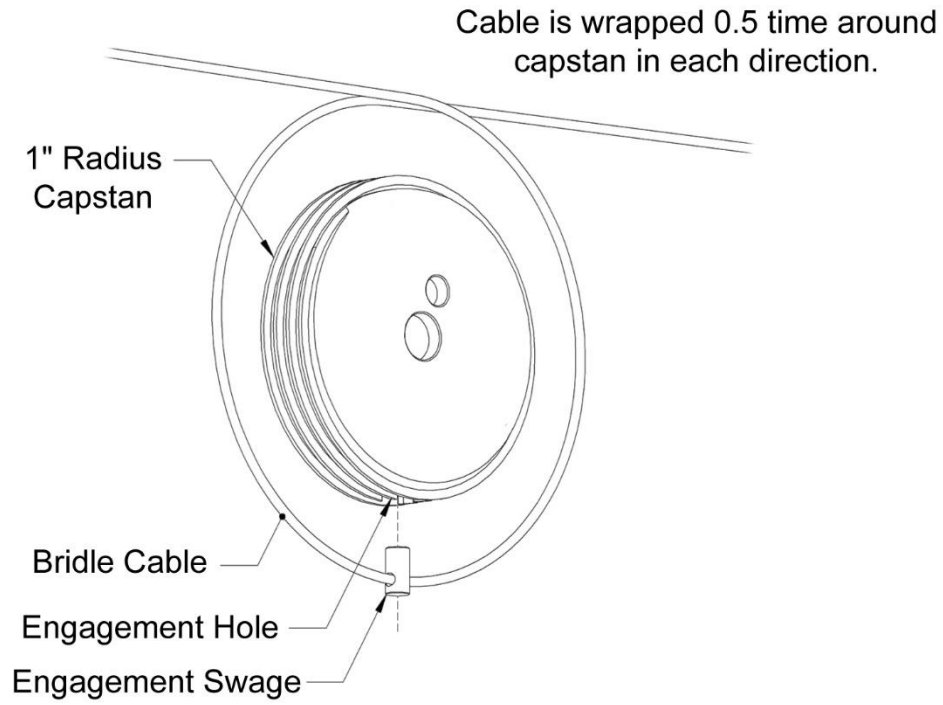

Figure 12: Roll Servo Bridle Cable Installation

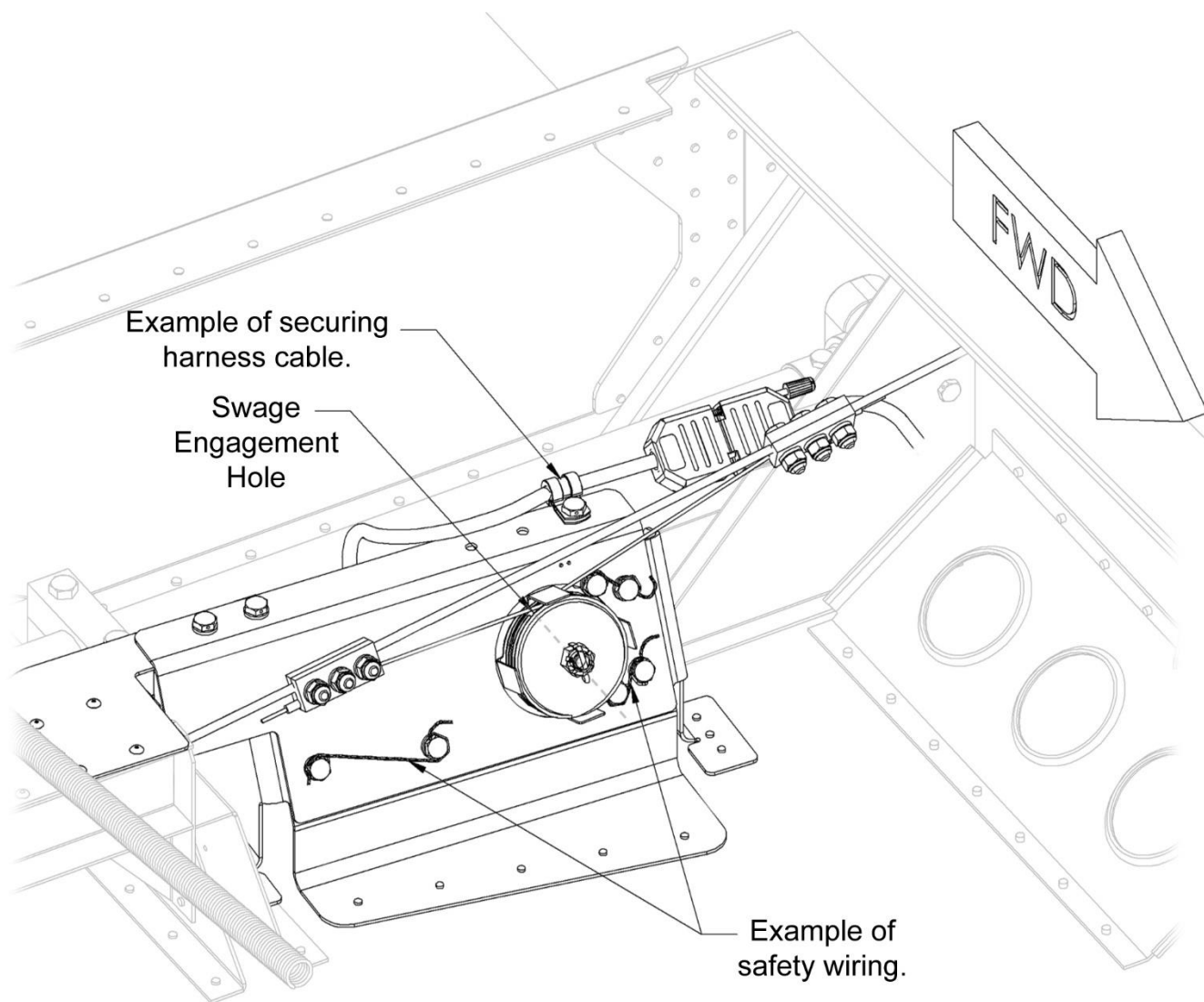

Figure 13: Roll Servo Complete Installation

9.3 Pitch Servo Parts, Assemblies, and Installation

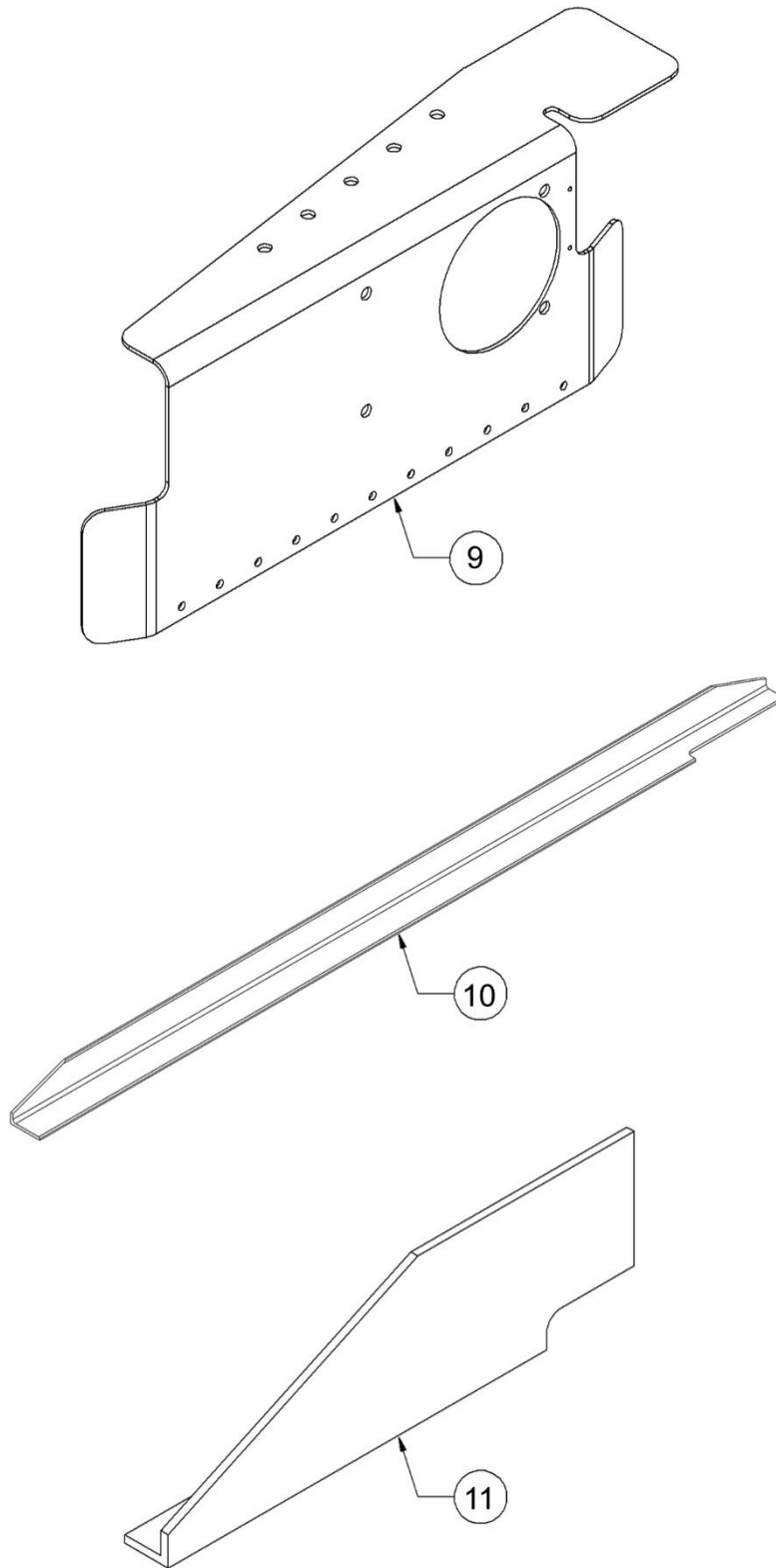

Figure 14: Pitch Servo Bracketry

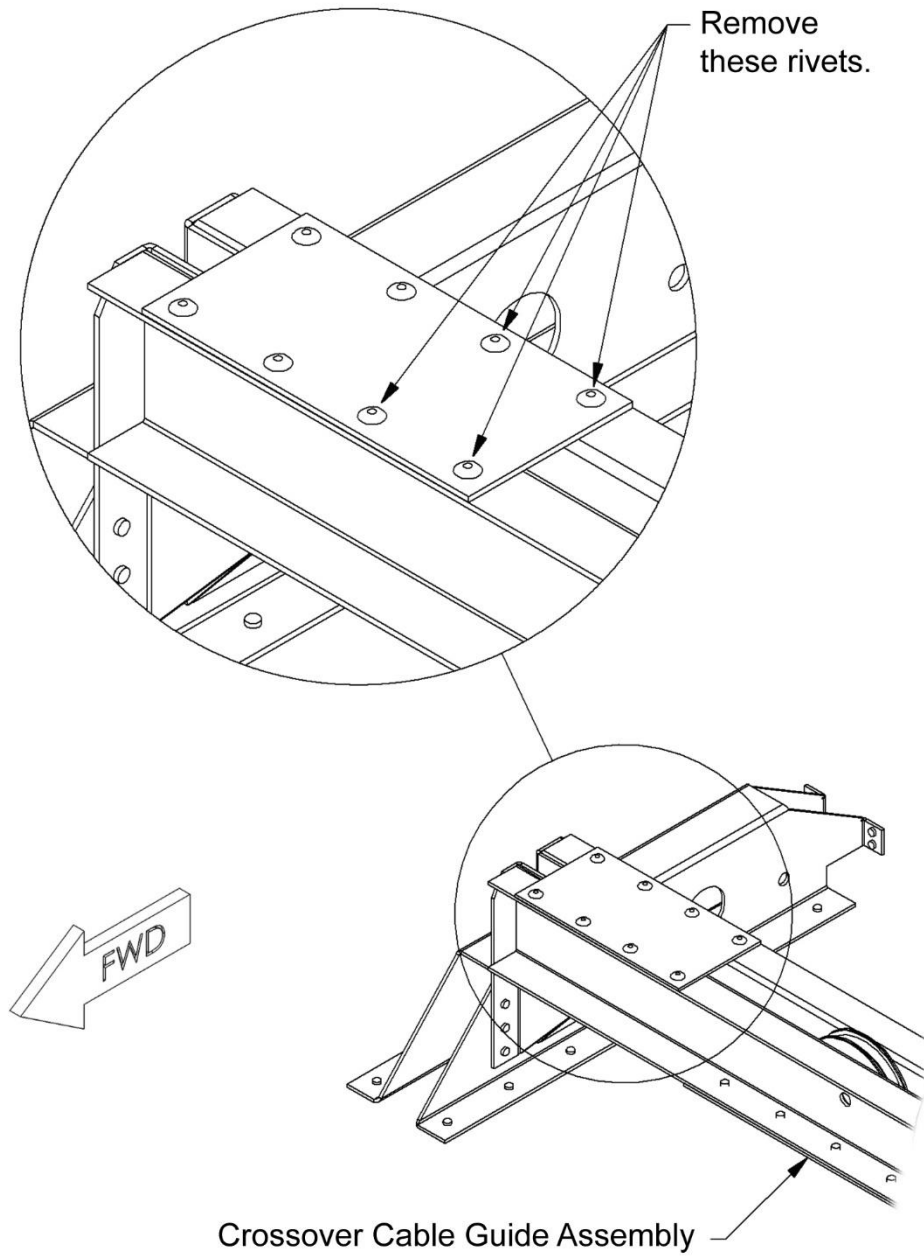

Figure 15: Pitch Servo Installation Preparation

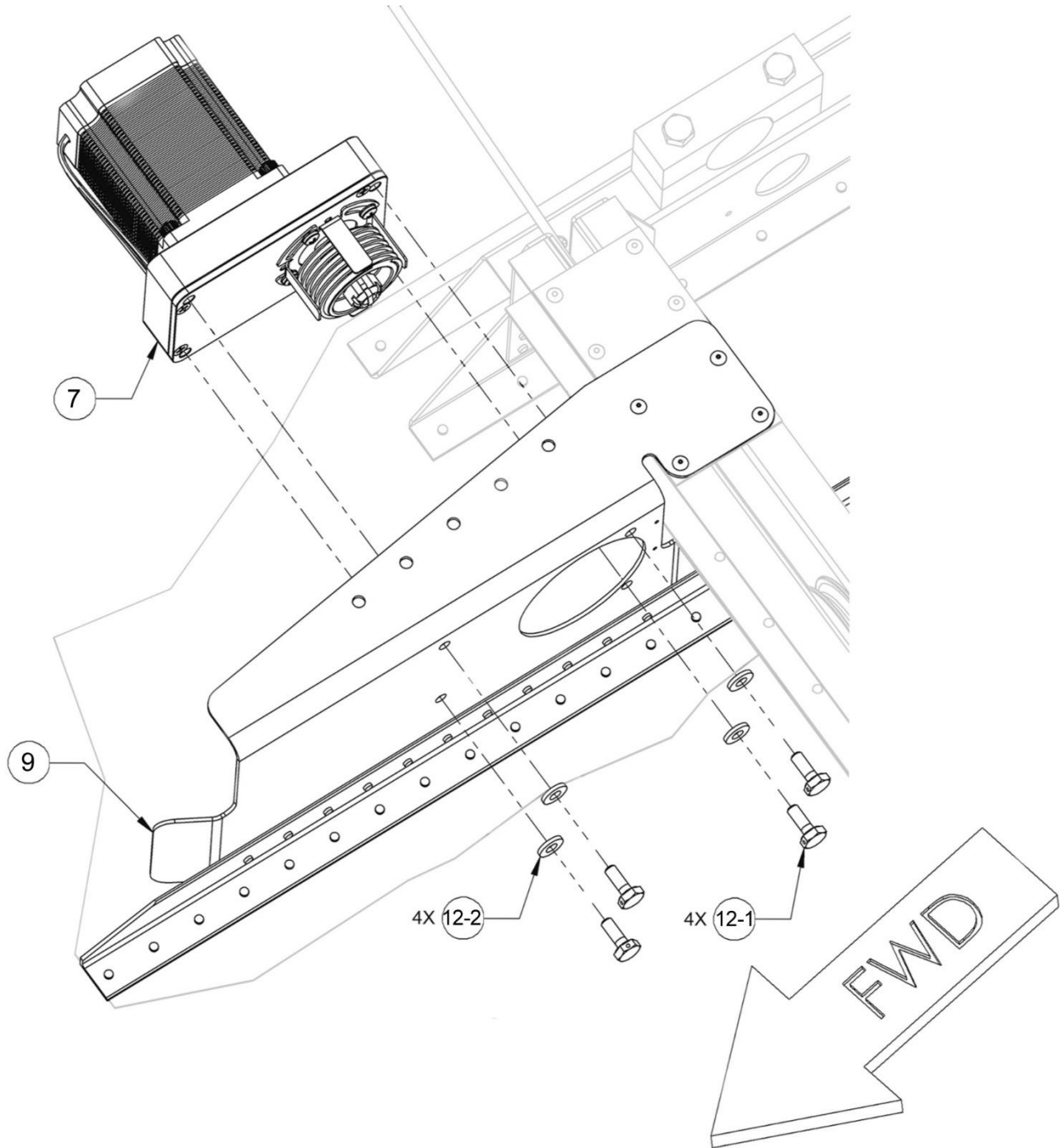

Figure 16: Pitch Servo Mount Bracket Assembly

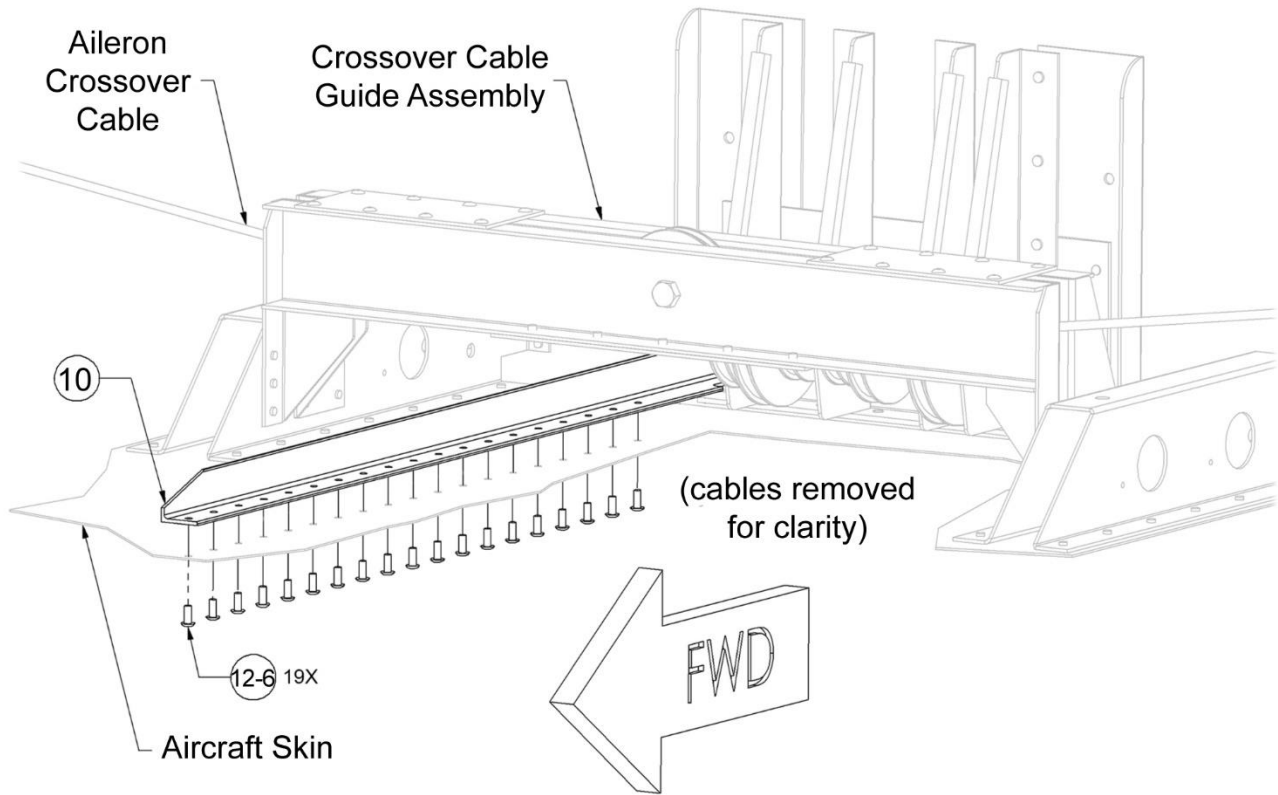

Figure 17: Pitch Servo Base Bracket Installation

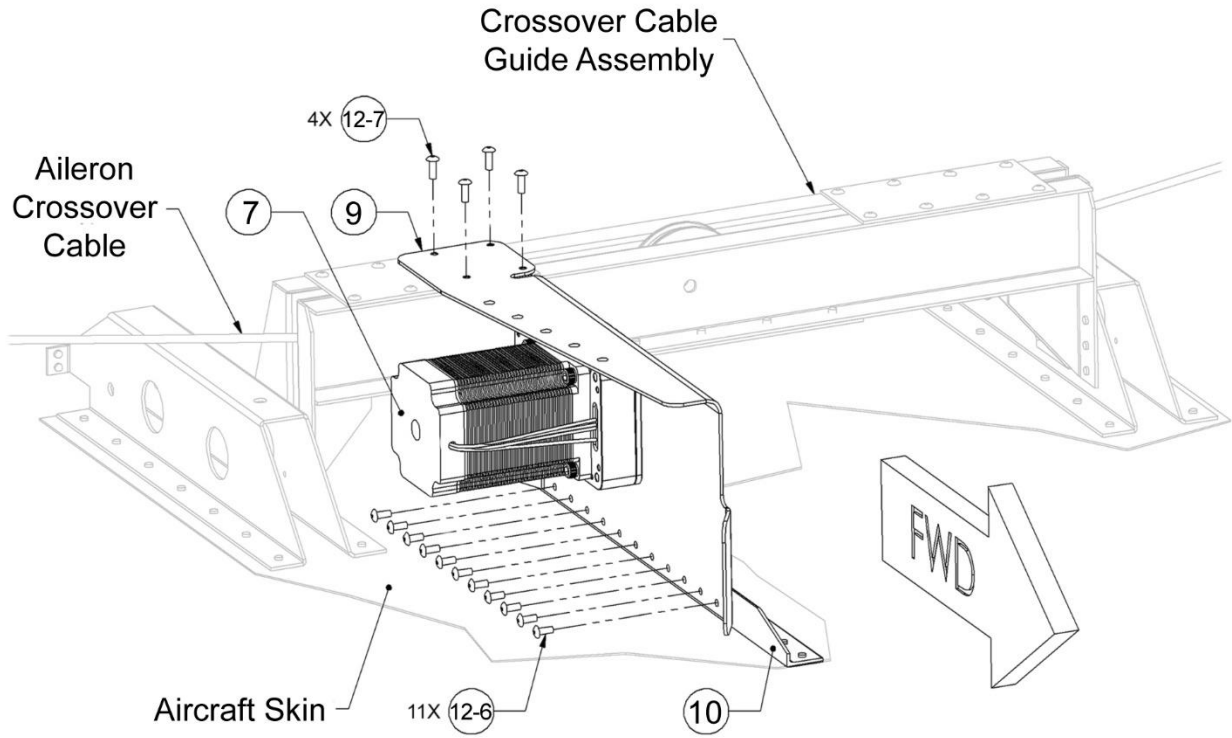

Figure 18: Pitch Servo Mount Bracket Assembly Installation

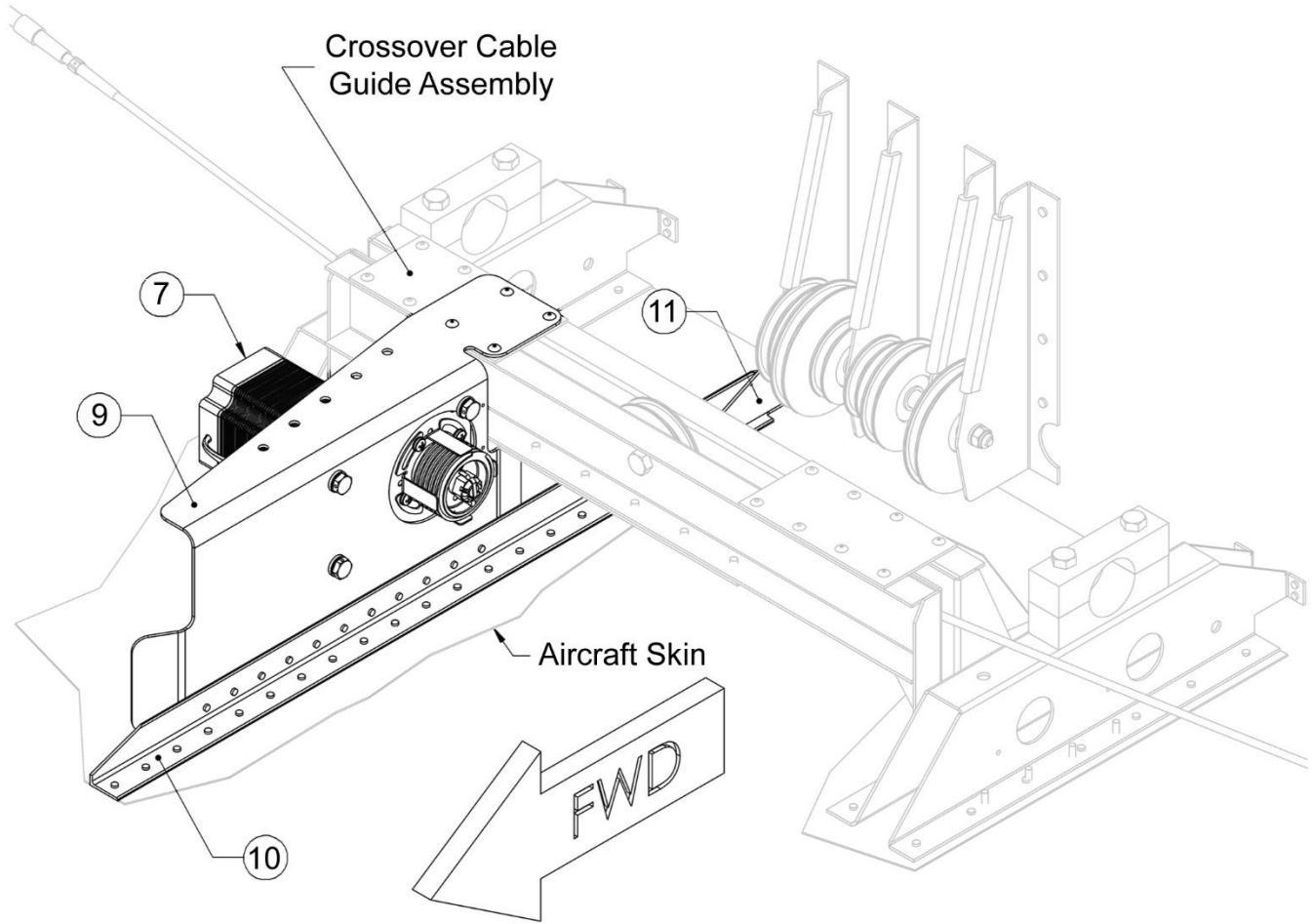

Figure 20: Pitch Servo Bracketry Installed

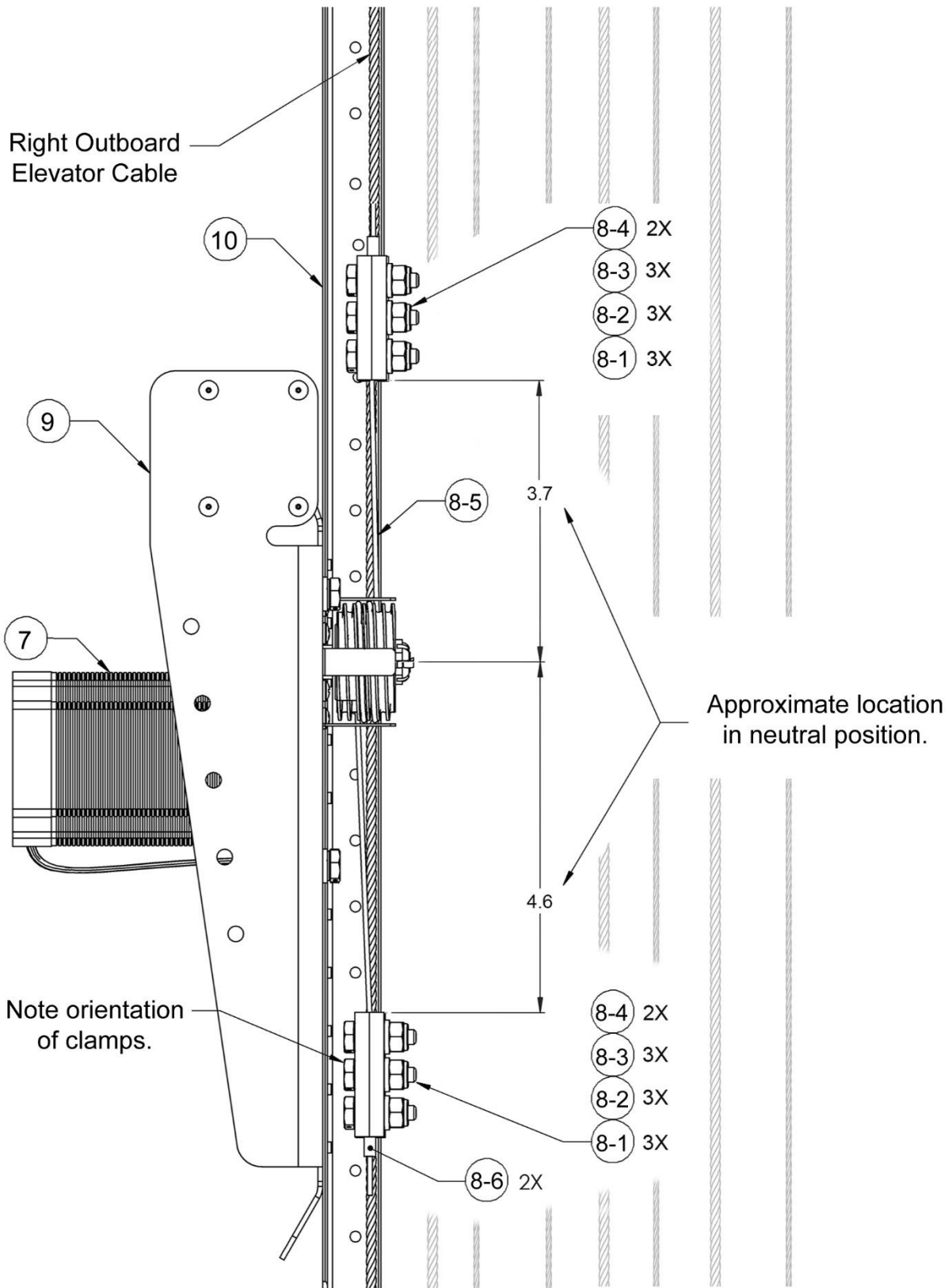

Figure 21: Pitch Servo Bridle Clamp Installation

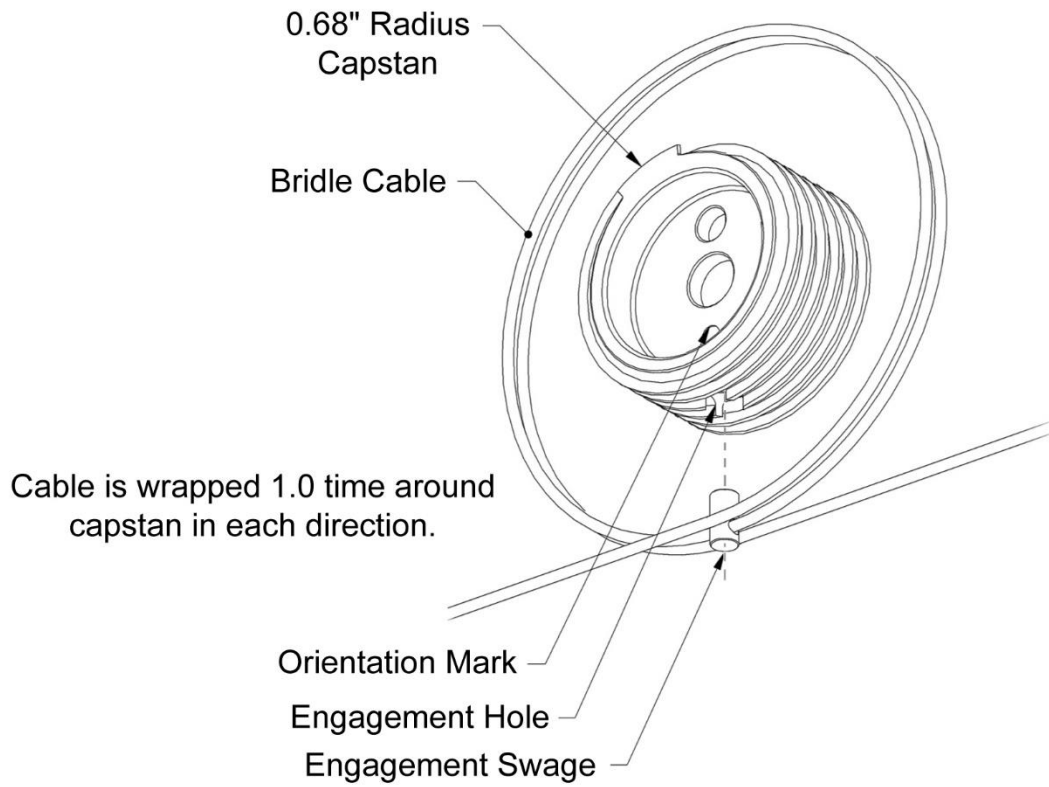

Figure 22: Pitch Servo Bridle Cable Installation

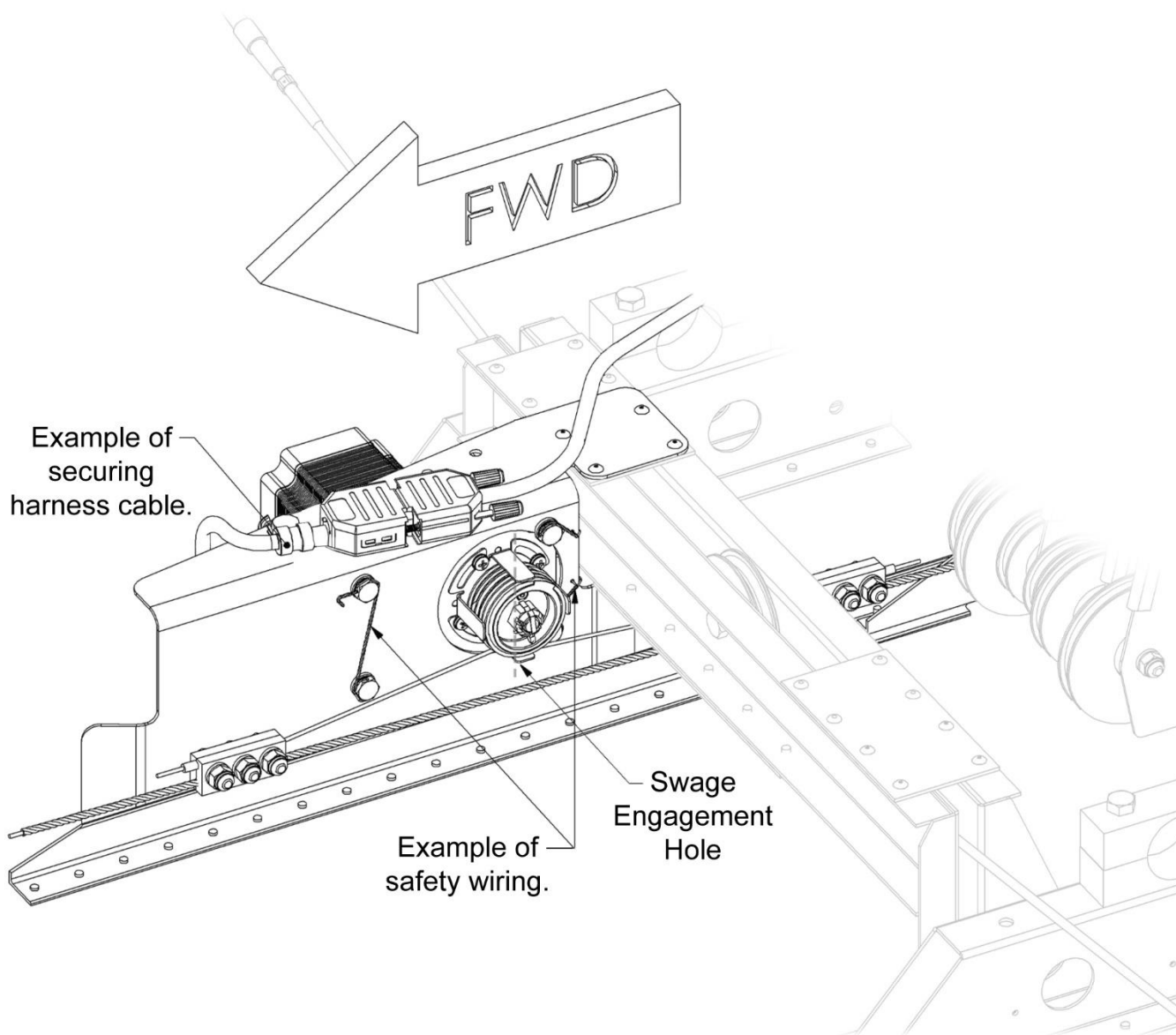

Figure 23: Pitch Servo Complete Installation

9.4 Servo Capstan and Cable Guard Installation

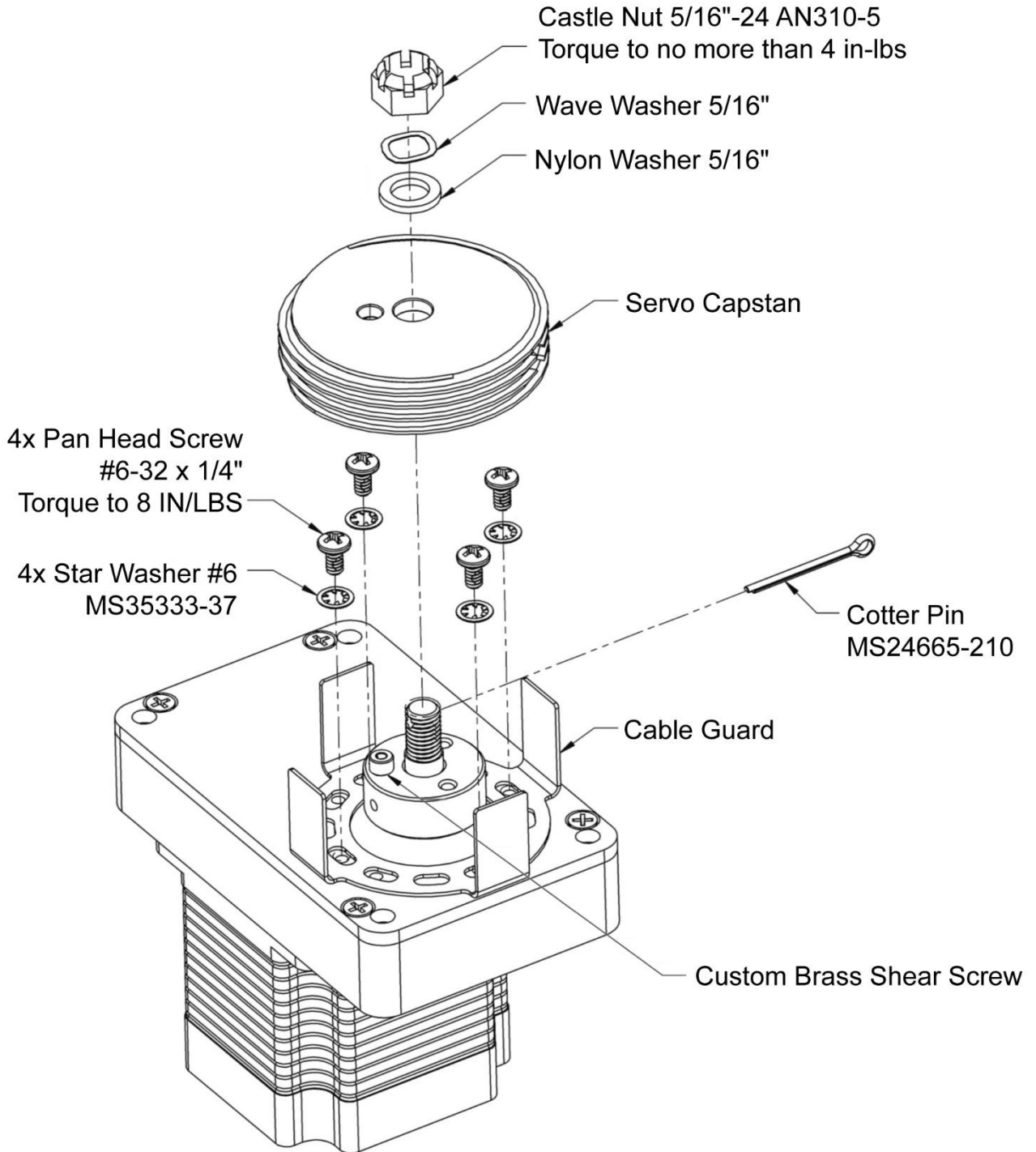

Figure 24: Servo Capstan and Guard – Exploded View (Roll Shown, Pitch Similar)

10 Appendix A: Pneumatic Tube Rerouting

This appendix provides instructions and illustrations to help installers reroute the pneumatic tube for the right wing de-ice boot.

To reroute pneumatic tube for right wing de-ice boot:

1. Make sure airplane master power is *OFF*.
2. Access area where pitch servo and bracketry will be installed (see Section [6.3.1: Location and Access](#)).
3. Identify section of pneumatic tube that requires rerouting (see [Figure 25](#) and [Figure 26](#)).
4. Source correctly-sized and comparable tubing and elbow connectors.
5. Re-route section of tube as needed using standards and practices outlined in *AC 43.13-1B, Chapter 9, Section 2*. (See [Figure 25](#) and [Figure 26](#) for examples).
6. Move all flight controls through full range of motion, making sure rerouted tube does not interfere with any control cables.
7. Perform functional test of pneumatic de-ice system per aircraft maintenance manual to verify boots inflate properly, and that no leaks in pneumatic tubing are present.

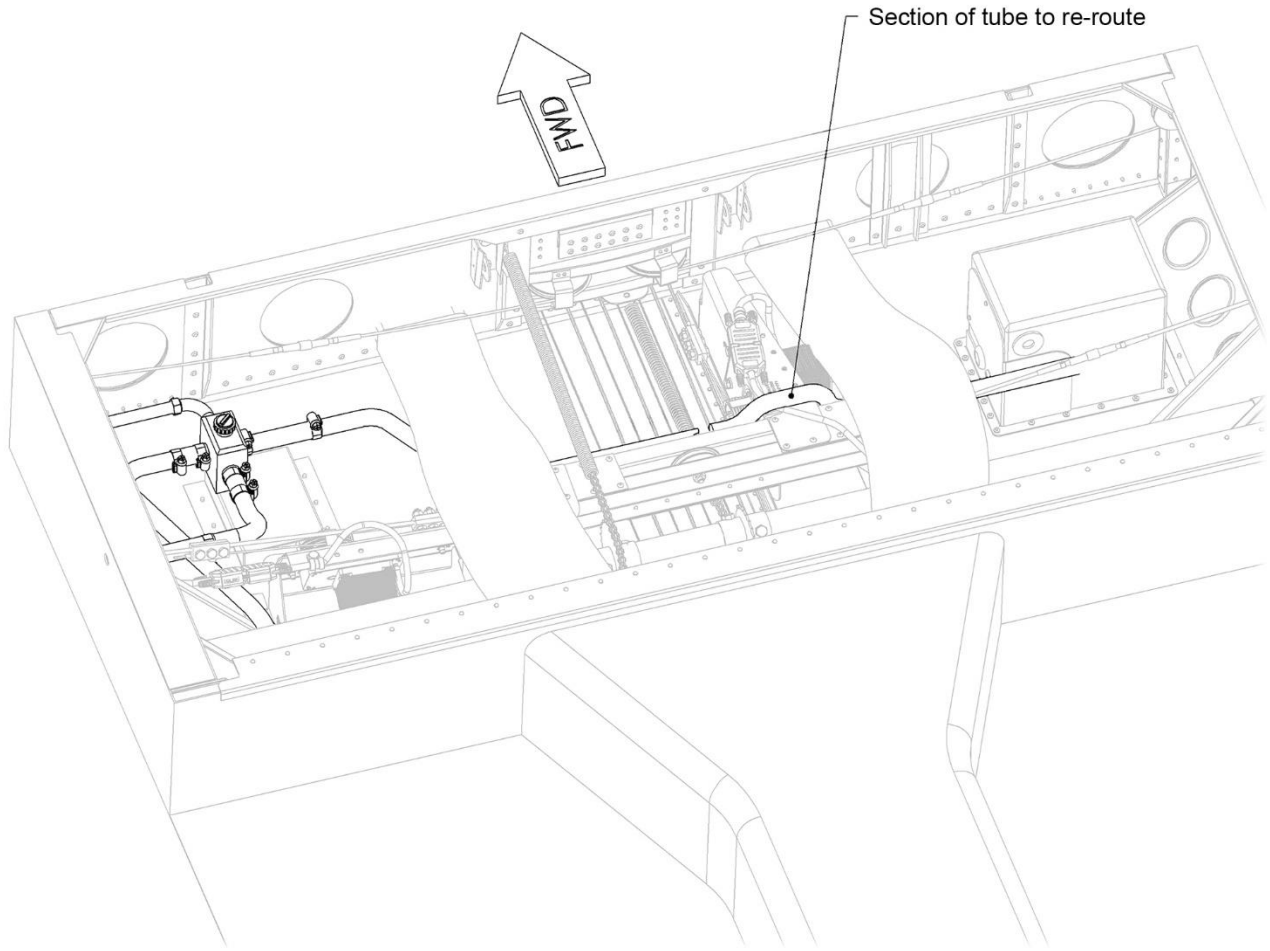

Figure 25: Pneumatic Tube Reroute — Example #1

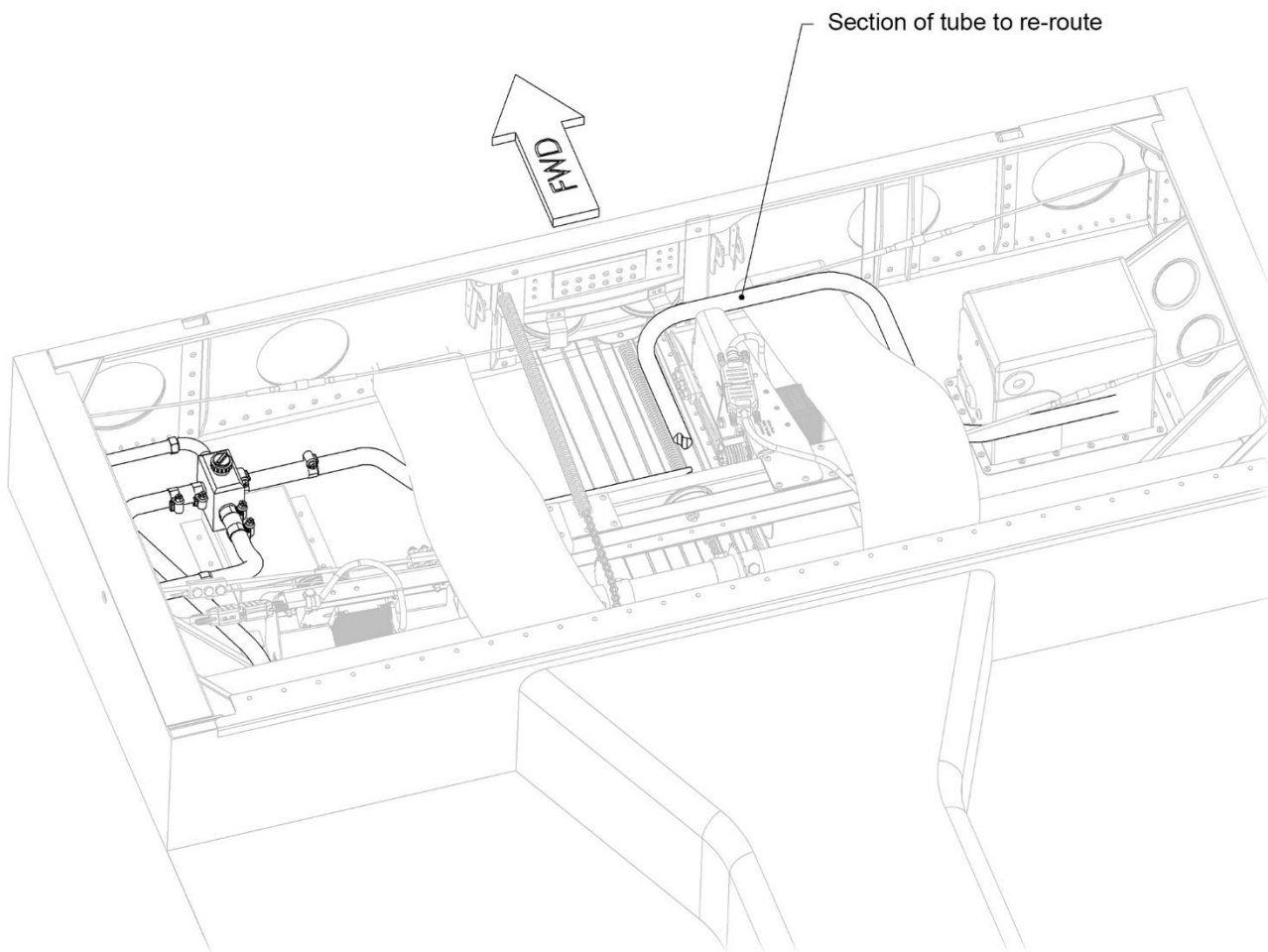

Figure 26: Pneumatic Tube Reroute — Example #2